

User Guide

Updated June 2024

➤ [How to care for your VELFAC windows and doors](#)

VELFAC[®]
WINDOWS FOR LIFE

Welcome to VELFAC Windows

Our commitment to quality ensures that your VELFAC windows will retain their looks and functionality for years with the minimum of care.

In this guide you will find an instruction in how to care for your VELFAC windows and doors. We hope that by using this guide, you will be able to make the most of your VELFAC windows and enjoy them for many years to come.

Please feel free to contact us if you have any questions which are not answered in this User Guide.

Kind regards
VELFAC

T: 01480 759 510
W: www.VELFAC.co.uk

Content

Operation failure, damage or break-ins	3
VELFAC After Sales Service.....	3
How to care for your VELFAC windows.....	4-5
Quality standards for the window industry	6-7
Product warranty	8
Condensation on your windows.....	9
Which type of windows do you have?.....	10
Technical terms	10
VELFAC 200 Windows.....	11-15
VELFAC 200 Casement and sliding casement doors	16-17
VELFAC 200 Handles and remote operation	18
VELFAC 200 Safety fittings and other accessories.....	19
Internal sash for VELFAC 200 windows	20
VELFAC Ribo Windows.....	21-25
VELFAC Ribo Casement, patio and sliding doors	26-28
VELFAC Ribo Handles, safety fittings and other accessories.....	29
Mullions and French Casements for 2-leaf windows and doors	30
VELFAC In Inward opening elements	31-32
VELFAC In Handles and accessories.....	33
VELFAC Ribo Entrance doors.....	34
VELFAC Fire element	35

Operation failure, damage or break-ins

Operation failure. If the window cannot be easily operated, check for any outside obstructions and remove. If the window resists closing, check for obstructions between the moving aluminium sash and the fixed timber mainframe. Ensure that no debris is obstructing the slide motion of the moving arm.

There are several steps you can follow to ensure your windows work properly:

1. Oil at least once a year with a few drops of teflon-based lubricating oil or a similar product:

- the bolts of the espagnolette handle (should be cleaned first)
- hinges
- locks and closing points in facade doors
- moveable fittings in the inward opening windows and balcony doors

Look under the current window or door where you must lubricate (see page 11-27).

2. **Weather seals, gaskets and glazing beads.** Check once a year that they are intact and functioning, and that there is no paint or lacquer on them. Paints/laquers make them stiff and they work best when they retain their smooth surface. For windows and doors to move easily you can lubricate the seals with silicone. New glass, seals, gaskets, glazing beads, valves and gaskets are available from VELFAC After Sales Service Department.

3. **Adjustment.** Are windows or doors operating poorly, or are the sashes hanging a little, often an adjustment can remedy the problem.

Damage or break-ins. If the window is operable after being damaged by forced entry or accident, it should be closed and secured. If the glass unit has been broken, any remains should be carefully removed taking all necessary safety precautions i.e. wearing protective clothing such as gloves, safety glasses, suitable footwear etc.

To restore building security, temporary glazing material (such as plywood or similar) may be glazed into the aluminium sash profile until a replacement glass unit is available.

In order to ensure your product warranty is maintained, please contact VELFAC After Sales Service to arrange repair of windows or to supply and fit replacement glass units.

VELFAC After Sales Service

A national system of service support ensures a fast and efficient response to any issues which may arise. A wide range of modifications and repairs are possible through VELFAC After Sales Service including:

- Supply and installation of replacement double-glazed units
- Supply and installation of replacement components
- Repair of damaged wood frames or aluminium sashes
- Conversion of fixed windows to opening
- Retro-fitting of restrictors
- Retro-fitting of electric motor openers

All our Service Engineers undergo a comprehensive training programme that equips them with interpersonal and problem solving skills, and in depth product knowledge. Using a VELFAC Engineer will ensure your 12 Year Product Warranty is maintained.



➤ **Order number.** All VELFAC windows carry a unique identity tag to enable immediate tracing of spare parts should damage occur.

How to care for your VELFAC windows

VELFAC window systems are easy to use and maintain but in order to ensure maximum lifespan it is important to inspect and service individual parts regularly. The correct cleaning and maintenance of your windows and doors will keep them looking good and ensure they will resist even the harshest weather conditions for years to come.

Cleaning and maintenance. The following cleaning and maintenance instructions should, as a minimum, be carried out according to the frequency below.

N.B. Your windows and doors will need more regular inspection and maintenance if they are installed in a harsh environment, such as a marine or industrial location or in areas of high internal humidity or if they are exposed to strong sunlight on south facing facades.

Cleaning periods are shown below with the recommended frequencies for harsh environments shown in brackets.

Item	Maintenance	Frequency (months)	service life (Years)
Timber	<p>The mainframe is manufactured from pine which has been coated with a 100% water-based diffusion open acrylic paint (gloss 20) or acrylic lacquer.</p> <p>The internal frame should be dusted and wiped clean regularly. Wood is a natural product containing resin. Occasionally beads of crystallised resin may form on the surface of the frame. These beads can be removed by gently rubbing with a cloth dampened with meths or other alcohol based substance.</p> <p>Some brushing with a stiff brush may be needed on external frames in order to remove any ingrained dirt. If any algae growth exists a fungicidal wash is recommended as a pre-treatment for external wood.</p>	<p>Cleaning internally: regularly</p> <p>Cleaning externally: 12 (harsh: 6)</p>	40+
Wood finish	<p>The inside and outside of the mainframe should be checked for breaches in surface treatment at least once per year.</p> <p>If the surface has been damaged it should be repaired promptly using a water-based diffusion open paint or lacquer to prevent the wood from absorbing moisture. Surface preparation should be limited to localised repair and very light sanding - wear respiratory protection as sanding can release propiconazole and titanium dioxide. Sanding dust must be collected and disposed of properly. Ensure that none of the gaskets or glazing beads are overpainted.</p> <p>All paint should be dried and cured as thoroughly as possible prior to fully closing the sash against the frame. Fixed sashes should be removed to enable all exposed timber surfaces are painted.</p> <p>Thresholds of hardwood in VELFAC Ribo doors should be maintained as wood finish. Mahogany bottom frames in a VELFAC In tilt and turn door can be treated with a raw linseed oil without colour pigmentation.</p> <p>The external side of the flush door leaf must be painted with 100% water-based acrylic paint at least every three years to maintain the finish.</p> <p>If using masking tape, we recommend a UV-resistant type. Ensure the tape is removed as soon as possible and before the paint has dried.</p>	<p>Check: 12 (harsh: 6)</p> <p>Repair: Promptly upon identification</p> <p>Paint: 36 (harsh: 18)</p>	15+

Item	Maintenance	Frequency (months)	Service life (Years)
Aluminium	<p>The external window/door sash/frame is made from aluminium with a powder coated finish. It will need cleaning at least once a year with a soft cloth or soft bristle brush and luke warm water with a few drops of mild detergent.</p> <p>Black stripes from gaskets will be harder to remove, if allowed to sit for long periods and materials such as paint, wet concrete etc. must be washed off immediately.</p> <p>A scratch will not affect the durability of the sash as the aluminium will form a natural layer of oxide. Scratches in the surface treatment can be repaired with repair lacquer, but differences in colour may occur.</p> <p>If atmospheric pollution has resulted in heavy soiling of the coating, then nothing stronger than white spirit should be used. Abrasive cleaners or chemical cleaners containing ketone, esters or alkalis should not be used.</p>	Cleaning: 12 (harsh: 6)	40+ although some discolouration from weathering may occur after 20-30+
Glazing	<p>Window glazing should be cleaned with a soft cloth or soft bristle brush and luke warm water with a few drops of mild detergent - detergents must not contain solvents or abrasives. Hard brushing, scrubbing or the use of steelwool/-wiper will produce scratches and must therefore be avoided. To dry the window, use a window scraper, or wipe with a slightly damp Chamois leather or fine cloth.</p> <p>Traces left on the glass after removing stickers or glue can be cleaned with meths or other alcohol based substances. Marks from suckers can be removed with a non-scratching cleaning agent such as Citrus Cleaner, however we recommend to work on small areas at a time and care must be taken to avoid contact with other parts of the window.</p>	Cleaning: regularly	25+
Weather strips	<p>Weather strips should be cleaned using luke warm water with a few drops of mild detergent. They must be inspected for any damage and they must not come into contact with paint or wood preservative, or be overpainted. To facilitate smoother movement of windows and doors, you can lubricate the weather strips with a silicone maintenance product.</p>	Cleaning/caring: 12	40+
Gaskets	<p>Gaskets should be cleaned using luke warm water with a few drops of mild detergent. They must be inspected for any damage and they must not come into contact with paint or wood preservative, or be overpainted.</p>	Cleaning/caring: Internally: 3 Externally: 12	20+
Glazing bead	<p>The internal glazing bead in VELFAC 200 should be cleaned using luke warm water with a few drops of mild detergent. They must be inspected for any damage and they must not come into contact with paint or wood preservative, or be overpainted.</p>	Cleaning/caring: 12	40+
Ironmongery e.g. hinges, handles, fittings, screws...	<p>Once a year all ironmongery should be cleaned, inspected and moving parts lubricated with acid-free oil where shown in this User Guide, illustrated by .</p> <p>As a result of daily use and wear, <u>opening sashes</u> should be inspected annually and adjusted as needed to ensure that the sash is correctly positioned in the frame.</p> <p><u>Friction arms</u> should be adjusted where required, but never lubricated.</p> <p><u>Guide rails</u> may where necessary be sprayed with a teflon-based lubricant (do not use common mineral based oil).</p> <p><u>The external rainscreen</u> on inward opening doors should at least once a year be oiled with silicone lubricant.</p> <p>In harsh environments, ironmongery must be inspected and cleaned more frequently.</p> <p>Please note: Surface corrosion is not necessarily detrimental to the operation of the ironmongery. The product warranty applies to lack of function and is conditional upon the stated maintenance instructions.</p>	Cleaning/caring: 12 (harsh 6)	25+

Quality standards for the window industry

VELFAC manufactures windows to meet the very highest expectations. The quality of our parts and materials, with the best possible standards in manufacturing, combine to provide the VELFAC windows you expect.

We have also implemented some simple guidelines for our customers, which identify quality standards, and what is allowable for predominately natural materials - wood, aluminium & glass.

Aluminium

Visible aluminium surface defects that are not visible from 3m are acceptable and therefore not claimable. Surfaces should not be assessed in direct sunlight.

Wood

Pine trees used in the production of frames for VELFAC windows are grown in North-European forests, which mean they mature slowly - as a result the wood is denser and harder-wearing than standard pine. Wood is a natural material that is often uneven. We are making very specific demands on our suppliers to get a wood quality, which we can vouch for.

We treat the wood surface following the below mention rules:

- All surfaces should be treated with 100% water based acrylic paint or acrylic lacquer
- Surfaces, edges and joins must be uniform in color and gloss and be smooth to the touch
- Because wood is a natural product, there may be structural and gloss variations, scratches and other normal wood variations (e.g. in connection with knots)
- Wood contains natural resin. During the first 3-4 years, resin leakage may occur and crystallise on the wooden frame.
See treatment of resin extraction on page 4

Page 4 describes the maintenance requirements for the wood frame. Special consideration should be given to windows on South facing facades, in coastal locations, or where there is a high moisture content inside the room. The surface treatment should be checked at least once per year, and any break in the lacquer or paint should be repaired promptly.

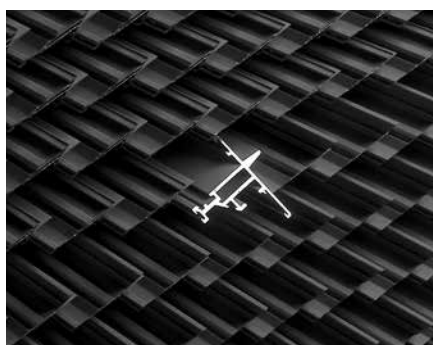

➤ Polyester powder coated aluminium is extremely weather resistant and does not rust or corrode.



➤ As wood is a natural material, some variations in finish are unavoidable e.g. where knots occur. VELFAC wood frames are finger-jointed and laminated to limit these occurrences.



➤ The Glass and Glazing Federation (GGF) publishes guidelines of modern glazing manufacture.

Please visit <http://www.ggf.org.uk/>

Glazing

All glazing is supplied by specialist manufacturers, and is produced within agreed standards outlined by the Glass and Glazing Federation (GGF). Glass impurities cannot be completely avoided, so minor occurrences are allowable within these standards. The document 'Visual quality standards for installed insulation glass units constructed from flat transparent glass', states the following:

- Both panes of sealed unit shall be viewed at right angles to the glass from the room standing at a distance of not less than 2 metres for toughened, laminated or coated glass, not less than a distance of 3 metres in natural daylight and not in direct sunlight.
- Flat transparent glass, including laminated or toughened (tempered) glass shall be deemed acceptable if the following phenomena are neither obtrusive nor bunched: totally enclosed seeds, bubbles or blisters: hairlines or blobs: fine scratches not more than 25mm long; minute embedded particles

Impurities, dirt and scratches. Larger scratches or marks within the glazed unit will be considered for replacement under the Product Warranty - please contact VELFAC with details. Scratches or marks on the external face of the glazed units cannot be covered by the warranty, as they are a result of handling after the transport packing has been removed. If the damage is a result of installation, please contact your installer.

Shades. Ordinary glass used in double-glazing is generally taken to be clear - but it is actually green. The colour reduces light transmission. Therefore, two pieces of glass of the same type but with different thicknesses can be perceived as if they have different shades of colour - this cannot be addressed.

Uneven heat across the glass surface can cause cracks due to thermal stress, which is not covered by warranty. Therefore, we advise that you do not:

- attach adhesive posters or signs to the window
- paint the window completely or partially
- attach adhesive plastic film or filters to the window
- create areas of partial shadow/shading
- blow hot air on the window (blow dryer, space heater, etc.)

Product warranty

The warranty covers manufacturing and material defects in windows within a period of 12 years from delivery date - all doors 5 years.

The warranty does not cover failures caused by improper installation, missing or inadequate maintenance or improper operation. Incorrect installation should be addressed with the window installer.

Below you can find a selection of questions we are frequently asked. If, however, you have a technical question which is not included, please call us on 01480 759 510.

Question: I have new windows, but they do not operate properly.

Answer: New windows should work perfectly and it is up to the window fitter to ensure they do before handing over the building. You should consult your window installer and ask him to look into the matter.

Question: I had new windows installed a few years ago. Now there are yellowish-brown stains on the paint.

Answer: Wood is a living product, so resin is a natural condition. Please see how to treat resin spots on page 4.

Question: My VELFAC windows and doors are 14 years old, but now they do not operate properly.

Answer: It may be that the sash has dropped or shifted due to setting over time. The sash can be adjusted. See www.VELFAC.co.uk to find our Installation & Adjustment Guide with instructions on how you can adjust VELFAC windows and doors. Alternatively, you can contact our After Sales Service Department for a quotation for this work.

Question: I have newly installed windows in my house, and I can see that there are scratches on the glass.

Answer: Glass imperfections cannot be completely avoided, so minor occurrences are allowable within the guidelines of modern glazing manufacture - for more information contact the Glass and Glazing Federation (GGF). Larger scratches or marks within the glazed unit will be considered for replacement under the Warranty - please contact VELFAC with details. Scratches or marks on the external face of the glazed units cannot be covered by the warranty, as they are a result of handling after the transport packing has been removed. If the damage is a result of installation, please contact your installer.

Question: My windows are no more than a few months old, and already they need to be oiled.

Answer: It is possible windows and doors only a few months old need oiling as when VELFAC windows leave the factory, they are lubricated, but only minimally so as not to attract dust and dirt. The next time the hinges and locker mechanism need cleaning and lubricating depends on how often the windows and doors are opened and closed, wind and weather in the area, and the season.

Question: I am unable to close my window.

Answer: Have you disengaged the restrictor? Refer to page 19 for further guidance.



> See the detailed conditions for the guarantee of our warranty statement that can be downloaded at www.VELFAC.co.uk

Condensation on your windows

Condensation appears naturally, when humid warm air meets cold air. Most people have experienced condensation on their bathroom mirror, the same principle applies to windows of a house.

Exterior condensation. Due to the low-energy insulated glazing used in modern windows, condensation may form on the outside pane. During colder months, the external surface of the outer pane cools faster than the inner surface due to the energy coating on the glass reflecting heat back into the room. The reduction of the heat transferring through the glazing unit results in a lowering of the external pane temperature and thus moisture in the external atmosphere can then form small droplets of water against the outer pane of glass. This kind of condensation demonstrates the effectiveness of the low energy glazing in all modern low energy window systems. The condensation usually forms early in the morning and will disappear as the external temperature rises.

Internal condensation has to be dealt with to keep it to an absolute minimum, though it may not be completely avoided. It forms when warm moisture held in the internal atmosphere cools against the glass and forms small droplets of water. Because warm air can hold more moisture, condensation increases as the room temperature is lowered and improves as the temperature rises.

Heavy condensation indicates high humidity due to poor air circulation. A humid indoor climate is unhealthy for both people and windows, therefore a relative internal humidity of maximum 45% during winter is recommended. There are three important measures to combat condensation:

- Rooms should be aired thoroughly two or three times a day for at least 10 minutes, even when raining
- A consistent indoor temperature of 20-22°C should be maintained
- Good air circulation in all rooms should be ensured - leave internal doors between rooms open

Condensation between the glazing panes. If condensation forms between the glazing panes, the sealed double-glazed or triple-glazed unit has been punctured and must be replaced. Please call the VELFAC After Sales Service Department.

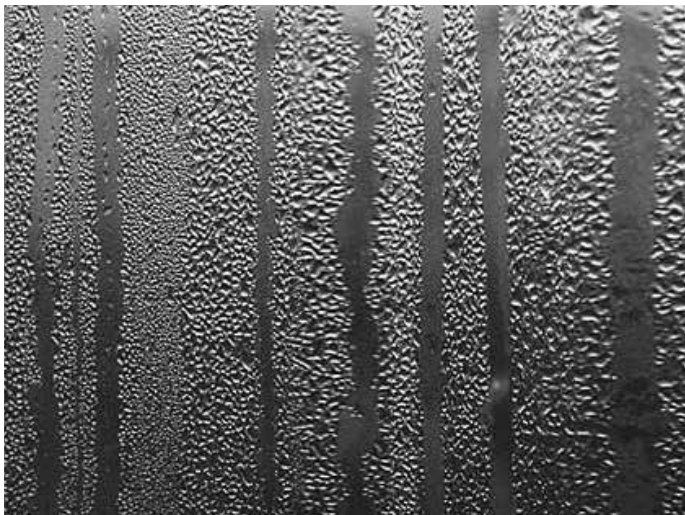

Did you know that...

- You must air new-build properties more regularly than old ones - this also applies to refurbishments or extensions
- People give off approximately 2L of water every 24 hours - airing is the only way to remove it
- Pot plants deliver most moisture
- Condensation increases as the room temperature is lowered and improves as the temperature rises.

If condensation has recently formed, it may be due to:

- Recently installed windows which are completely air tight
- Installation of under floor heating
- New curtains
- Moisture in new houses - it may take as long as a year to dry a new house completely
- The season - condensation is more likely to occur in autumn and winter.

Which type of window do you have?

You need to establish which VELFAC window system you have to understand how they operate and what adjustments are possible. Please take a look at the diagrams and the descriptions to decide which windows you own.

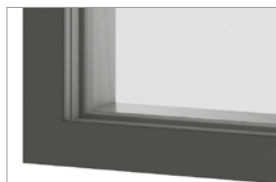

VELFAC 200

VELFAC 200 windows and casement doors have a single sightline on the external side and are outward opening.



VELFAC In

VELFAC In windows and Juliette doors are inward opening.



VELFAC Ribo windows

VELFAC Ribo windows and casement doors are frame/sash models and are outward opening.



VELFAC Ribo doors

VELFAC Ribo patio, sliding and entrance doors are outward or inward opening as required.

Technical terms

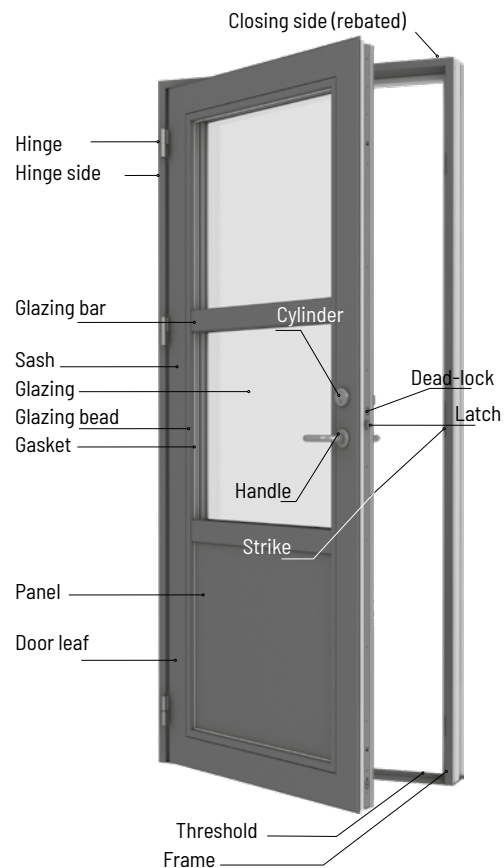
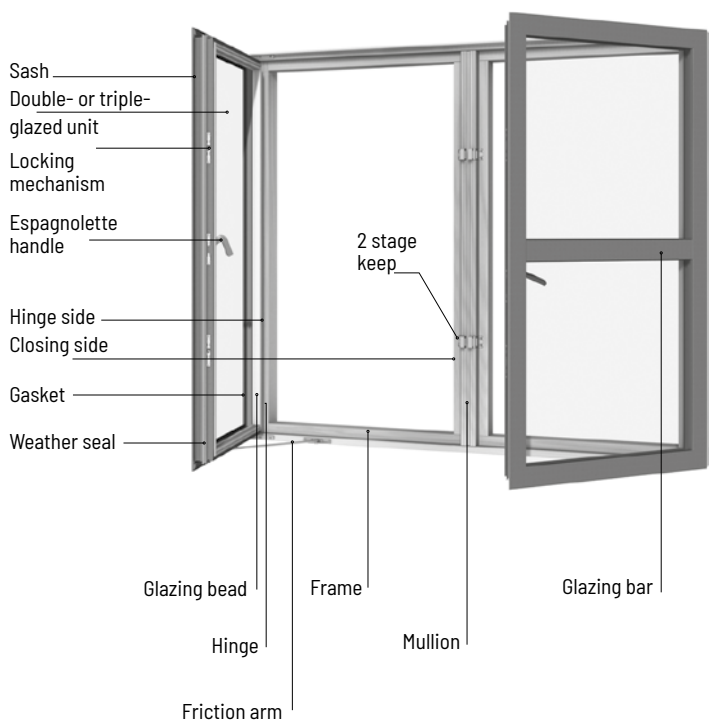

VELFAC 200 Topguided window

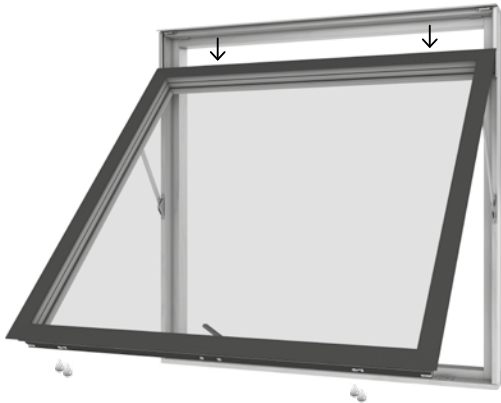

This window is opened by turning the handle to a vertical position and pushing the sash outwards. Opening the window will provide a ventilation gap at the head.

Adjustments. The friction arms can be adjusted by turning the screws at the sides of the casing using a 4mm hex key (1). It is important that the screws are tightened equally on both sides, to allow the sash to function correctly. Do not lubricate!

If you need to adjust the height of the sash in front of the frame, use a 5mm hex key and turn the adjustment screw (2) on one or both sides of the sash to adjust the sash up and down as required ($90^\circ = 2\text{mm}$).

Cleaning. Ensure that guide rails are free from dust and dirt by using a soft brush or cloth (3). The guide rails should not be oiled as this will accumulate dust and dirt, and remove friction.

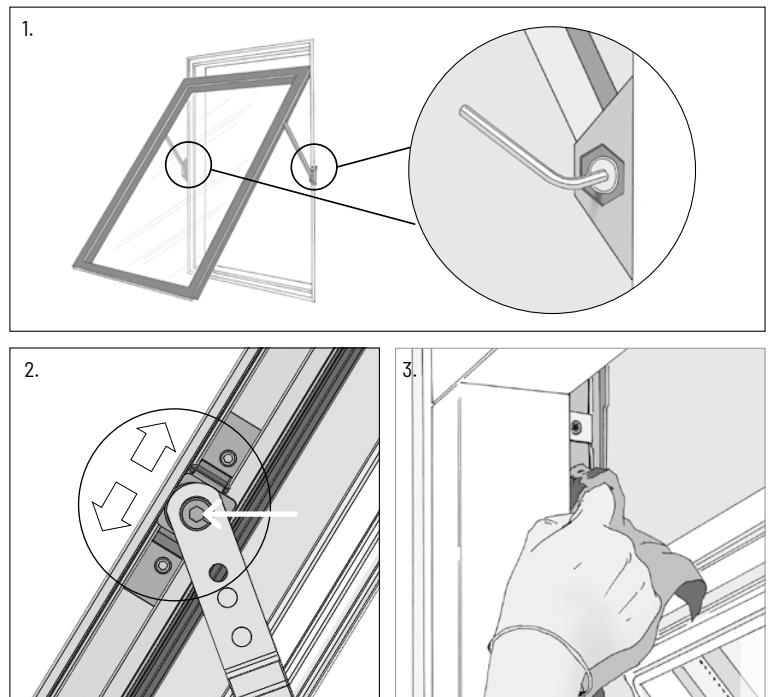

VELFAC 200 Sidehung window



This window is opened by turning the handle to a horizontal position and pushing the sash outwards. The window opens to 90° and is equipped with a friction arm which allows the sash to be held in any position between closed and fully open in calm weather conditions.

Double leafed windows can be supplied with different types of mullion - see page 30 for more information.

Adjustments. The friction arm (1), found at the bottom or top edge, can be adjusted by loosening or tightening the friction screw using a 4mm hex key. Do not lubricate!

If you need to adjust the height of the sash in front of the frame, ensure the sash is fully supported, and using a 3mm hex key loosen the screws (2) in the sash next to all hinges and move the sash up or down as required. Tighten the screws again.

Care. It is important to keep the guide rails free of dust and dirt by using a soft brush or cloth (3). The guide rails should not be oiled as this will accumulate dust and dirt, and remove friction. The hinges require oiling using acid-free oil. In order to ensure the hinges are properly lubricated, the window should be opened and closed several times during and after oiling (4).

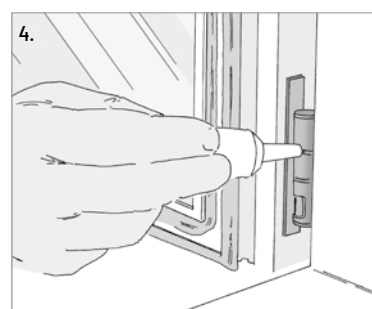
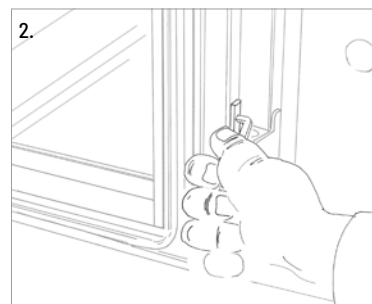
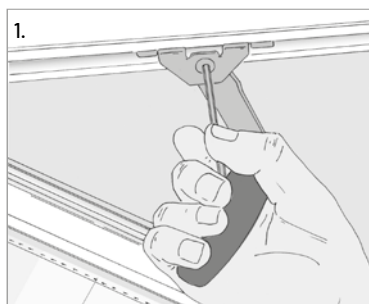

VELFAC 200 Sideguided window



This window opens by turning the handle to a horizontal position and pushing the sash outwards.

Cleaning. When the sash is fully opened, a gap is formed at the hinge side. This allows the external side of the sash to be cleaned from inside the building.

Adjustments. Friction in the guide rails can be adjusted by turning the screws at the top and the bottom of the window sash with a 4mm hex key (1).

The sash can be adjusted side to side by turning the screw in the guide arm at the top (2) and bottom (3) of the frame using a 5mm hex key.

If you need to adjust the height of the sash in front of the frame, use a 5mm hex key and turn the screw in the bottom hinge (4) to move the sash up or down as required.

Care. Guide rails should be kept free of dust or dirt by cleaning with a soft brush or cloth. (5+6). The guide rails should be sprayed with teflon-based lubricating oil or a similar product once a year, as a minimum (never all-round lubricating oil!).

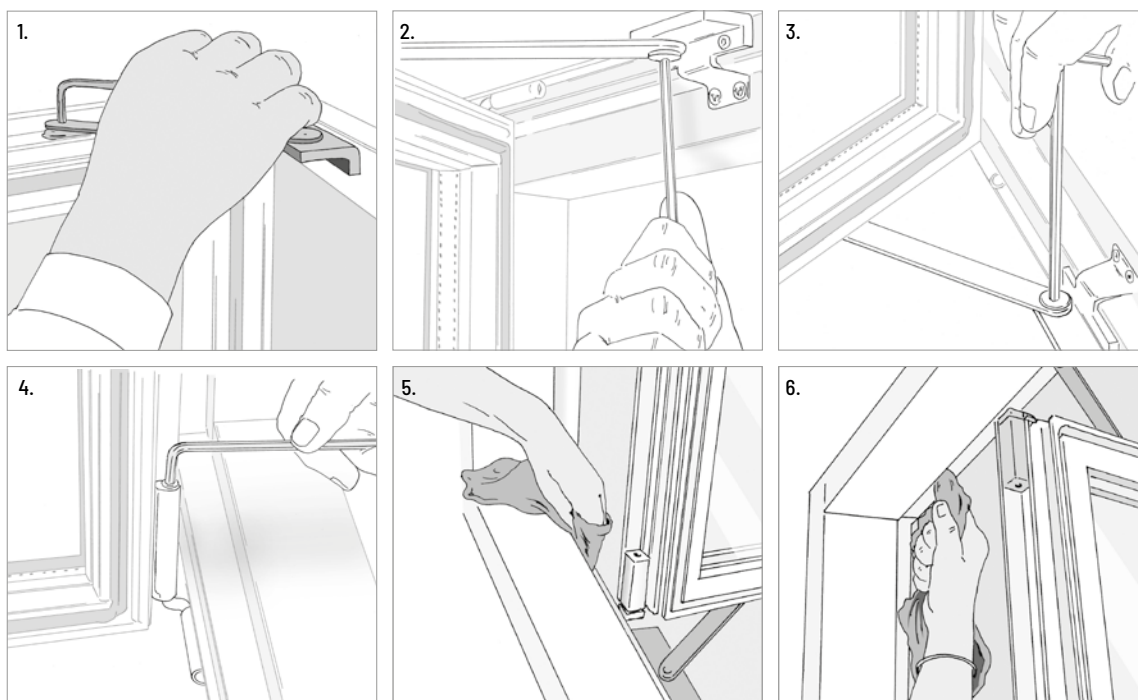

> At VELFAC.co.uk and YouTube, you can watch a video about how to operate the window.

VELFAC 200 Fixed casement



A fixed window cannot be opened and therefore requires no maintenance or adjustments of opening fittings.

Fixed windows can be converted to opening. Please call VELFAC After Sales Service on 1800 292929 for more information.

VELFAC 200 Tophung window

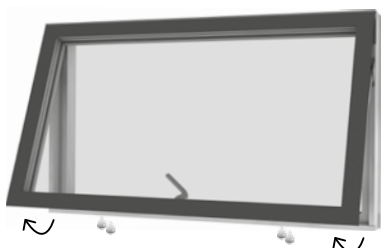

This window is opened by turning the handle to a vertical position and pushing the sash outwards.

If the window is installed as an **emergency exit**, a latch on the left side of the sash will hold it in a open position to a 35-55° angle (3). To close the window, the latch must be lifted out of the notch first. The sash can also be opened up to 85° to facilitate emergency exit but cannot be secured in the open position.

Adjustments. The friction arms can be adjusted by turning the screws on both sides of the casing with a 4mm hex key (1). It is important that the screws are tightened equally on both sides, to allow the sash to function correctly. Do not lubricate! If you need to adjust the height of the sash in front of the frame, use a 3mm hex key to loosen the fixings (2) and move the sash fittings up or down on both sides.

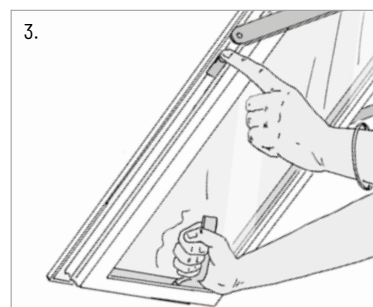
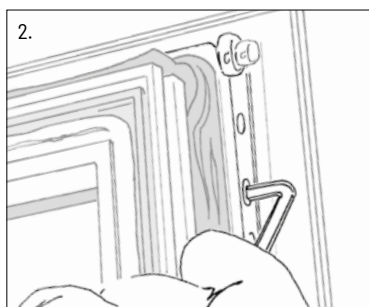
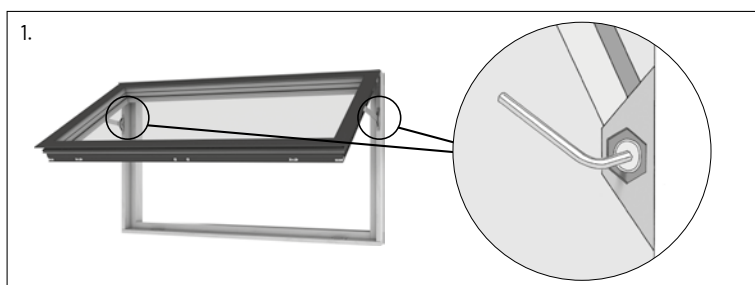

VELFAC 200 Reversible window

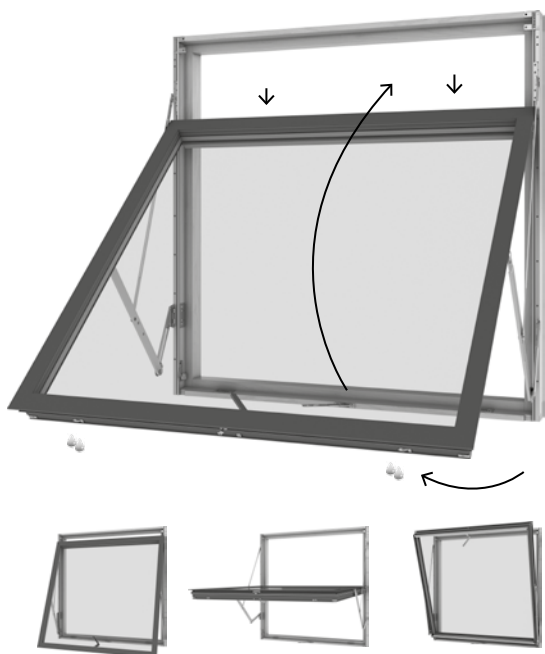

This window opens by turning the handle to a vertical position and pushing the sash outwards until the restrictor engages at an opening of 5-10cm.

Cleaning. The external side of the window can be cleaned from inside the building by reversing the sash. Open the window until the restrictor is activated. Pull back the window slightly and detach the restrictor (1). The restrictor has a lock function. When locked, the window cannot be reversed for cleaning (see more on page 19).

Push the window outwards - DO NOT LEAN OUT while doing so. When pushed outwards, the top of the sash can be pulled gently downwards toward the bottom of the window. The sash is fully reversed when the catches engage to keep it in the cleaning position (2+3). Make sure the sash is fixed in cleaning position before starting to clean.

When the sash has been cleaned, the catches can be disengaged (2+3): Pull back the window slightly and detach catch 1, move the sash slightly upwards and detach catch 2. Now the bottom of the sash can be guided back towards the top. The restrictor will automatically re-engage when the sash is closed. Never leave the window unattended while the restrictor is disengaged!

Adjustments. If you need to adjust or align the sash in front of the frame, first using a 3mm hex key loosen the 2 locking screws on the sash beneath the friction arm (4). Then using a 4mm hex key adjust the sash either up or down by turning the outer rivet above the friction arm (5) either clockwise or anti-clockwise. There are marks on the screws indicating direction. Finally using a 3mm hex key tighten the 2 locking screws again (4).

> At VELFAC.co.uk and YouTube, you can watch a video about how to operate the window and the opening restrictor.

Care. The guide rails of the friction arm should be kept free from dirt (6). They should be sprayed with a teflon-based lubricant or a similar product once a year, as a minimum (do not use common mineral based oil).

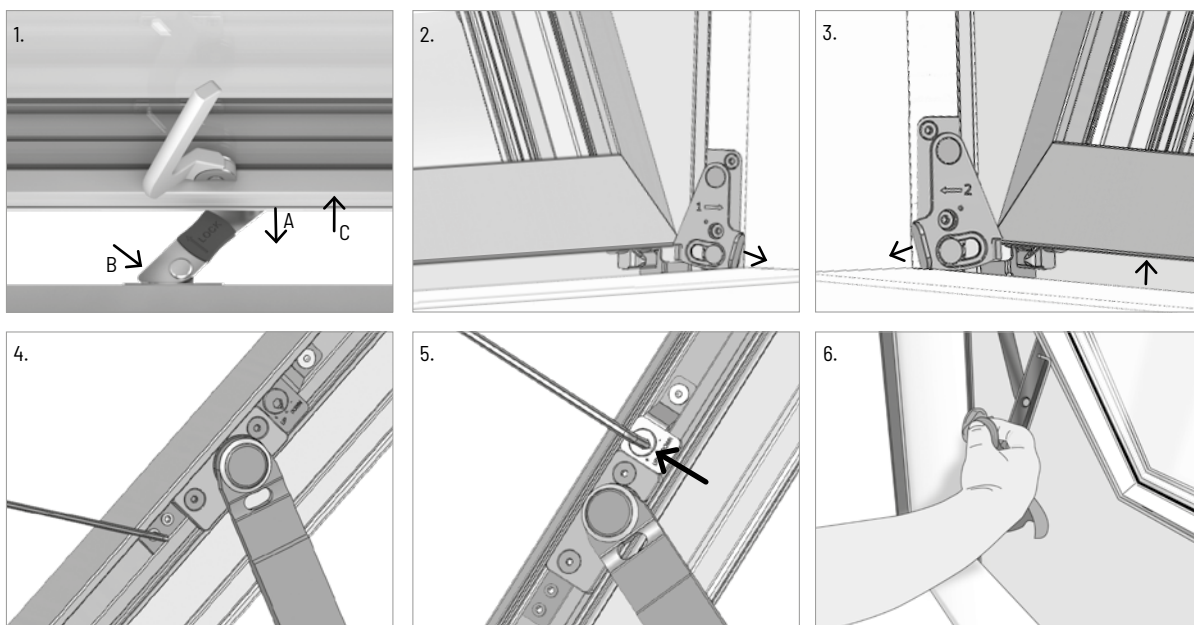

VELFAC 200 Casement door



The casement door is opened by turning the handle to a horizontal position and pushing the door leaf outwards.

The door has a handle operated brake. At any opening position (10°-85°) turn the handle down to a vertical position to activate the brake. To de-activate the brake, turn the handle to the horizontal position. In very windy conditions, you must close the door or ensure that the door does not over extend and cause damage.

Instead of the handle operated brake, the door may be equipped with a friction arm which allows it to be held in any position between closed and fully open in calm weather conditions. Doors can also be fitted with a hinge to allow 180° opening - see page 19.

Double-leaf doors are supplied with a French casement mullion - see page 30.

Adjustments. The handle operated brake (if any), can be adjusted when the casement door is opened completely. Align the screw head with the hole in the cover rail at the top of the sash (1). Insert the 2mm hex key into the screw head, then turn slightly clockwise to tighten the brake. 10-20° will usually be enough.

The friction arm (if any) is found at the top edge (2), and can be adjusted by loosening or tightening the friction screw using a 4mm hex key. Do not lubricate!

In doors with 24mm threshold, if you need to adjust the height of the sash (3), ensure it is fully supported and use a 3mm hex key to loose the screws (A) in all hinges. Then use a 4mm hex key to turn the adjusting screws (B) in the desired direction (UP/DOWN). Finally use a 3mm hex key to tighten the hinge screws (A) again (with 1.6-1.8Nm).

In doors with 15mm or 52mm threshold, if you need to adjust the height of the sash (4), ensure it is fully supported and use a 3mm hex key to loosen the screws in the sash next to all hinges. Move the sash up or down as required and re-tighten the screws.

In doors with 24mm threshold, if you need to adjust the sash side to side (3), use a stub 4mm hex key and turn the screws (C) max. ¼ turn at a time. Tighten both screws equally.

Care. It is important to keep the guide rails free of dust and dirt by using a soft brush or cloth (5). The guide rails should not be oiled as this will accumulate dust and dirt, and remove friction. The hinges require oiling using an acid-free oil. In order to ensure the hinges are properly lubricated, the casement door should be opened and closed several times during and after oiling (6).

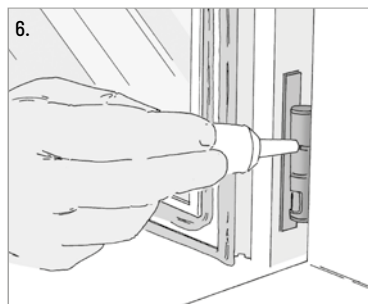
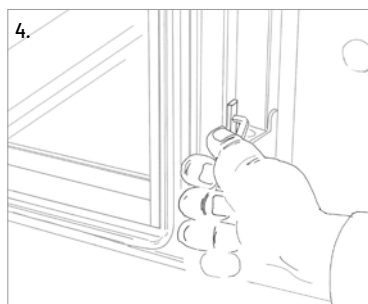
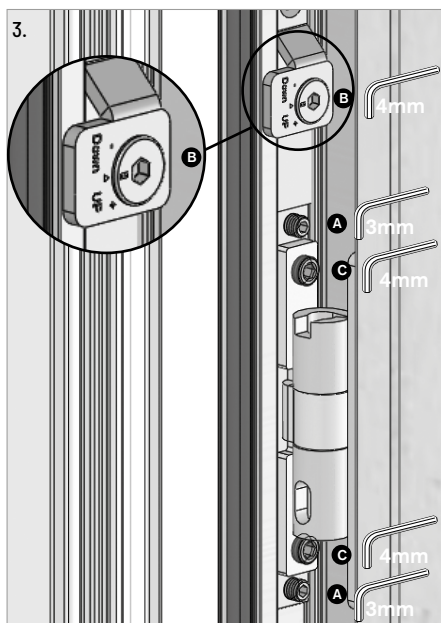
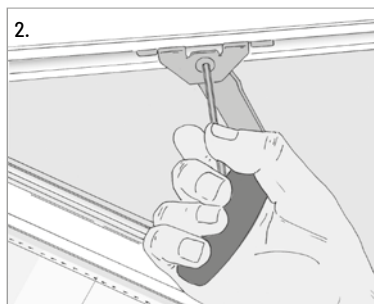
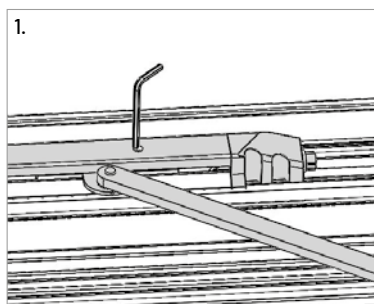

VELFAC 200 Sliding casement door



The sliding casement door is opened by turning the handles at the sides of the door leaf to a horizontal position. The door is then pushed outwards approximately 10cm and slid across.

The door is closed by sliding across and pulling back toward the frame. The handles are then turned back to a vertical position.

Double sliding doors are supplied with French casement mullion – see page 30 for more information.

Care. The guide rails must be kept free from dust and dirt with a cloth or soft brush. (1). When the front sliding truck – the hinge that moves in the slide rail at the leading edge of the door – looks like in illustration 2 it must be oiled with a teflon-based lubricating oil or a similar product (2). If it looks like illustration 3 the sliding truck is protected by a cover plate. This model should not be oiled (3).

Adjustment is quite complicated and should be entrusted to a professional. Therefore no further elaboration of adjustment can be found in this brochure. Information about adjustment can be obtained by contacting Customer Service.

> At VELFAC.co.uk and YouTube, you can watch a video about how to operate both the 1-leafed and the 2-leafed sliding casement door.

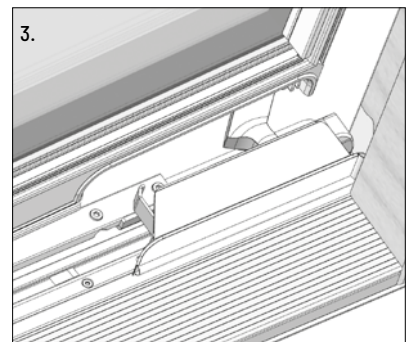
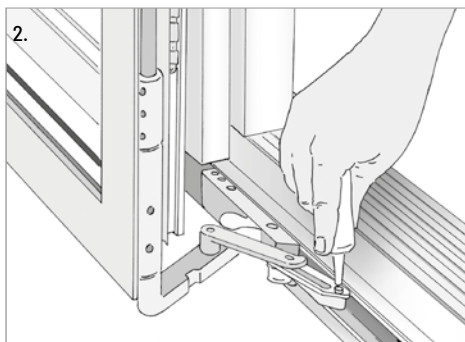
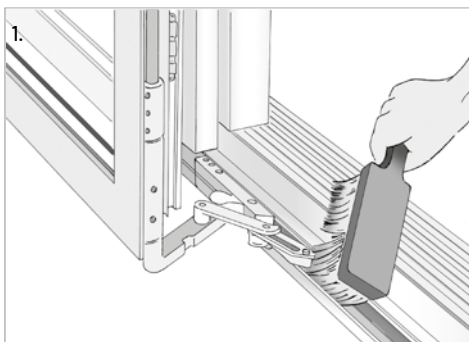

Handles and remote operation for VELFAC 200 windows and casement doors

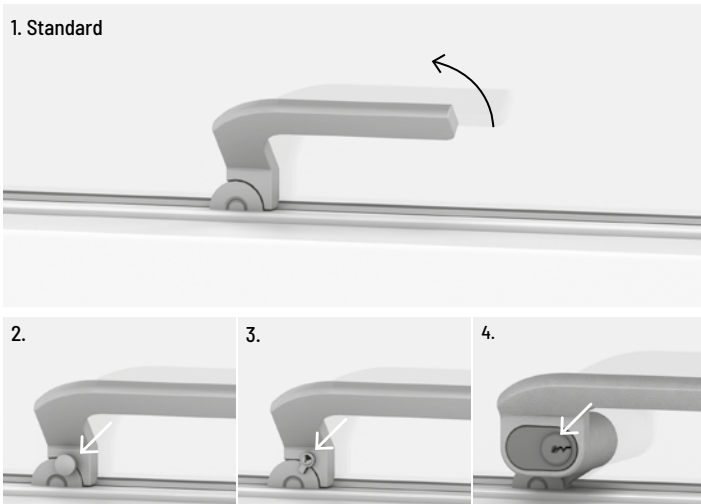

> Espagnolette handle types:

1. The espagnolette handle is tipped upwards to open the window.
2. Espagnolette handles with safety-locks can only be opened when the button below the handle is pressed while the handle is turned. The safety-lock will automatically re-engage when the sash is closed.
3. Espagnolette handles with locks are equipped with a small, removable key.
4. Espagnolette handles for cylinders can fit cylinders as part of a key strategy around a building.
5. A ventilation position is obtained by pushing out the window approx. 1cm and re-engaging the handle in the outer recess.

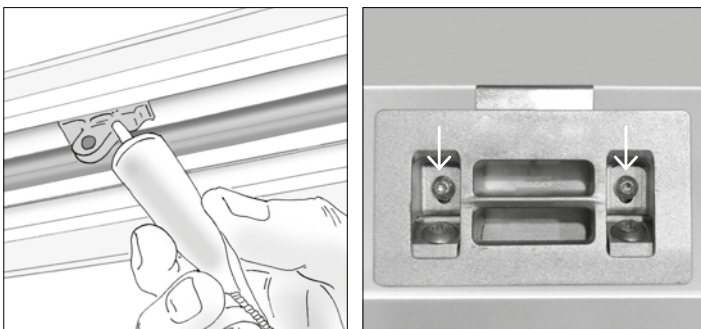

> **Care.** The bolts of the handle (6) require oiling, while operating the handle to ensure proper lubrication.

> **Adjust the closing pressure.** Loosen the screw fittings with a Torx 15 drive, relocate the plate (-1mm/+2mm) and re-tighten the screws.

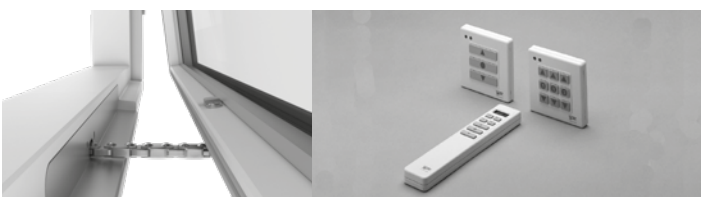

> **Remote operation** is operated via a panel on the wall - or a remote control. The window is opened with the arrow-up button, and closed with the arrow-down button. The remote comes in two versions:

The window moves while the button is pressed down - or by one short press and stop with the middle button. The metal chain of the remote operation should be kept clean.

> At VELFAC.co.uk and YouTube, you can watch a video about how to operate the espagnolette handle with safety-lock or with a small key as well as the WindowMaster motor.

Safety fittings and other accessories for VELFAC 200 windows and casement doors

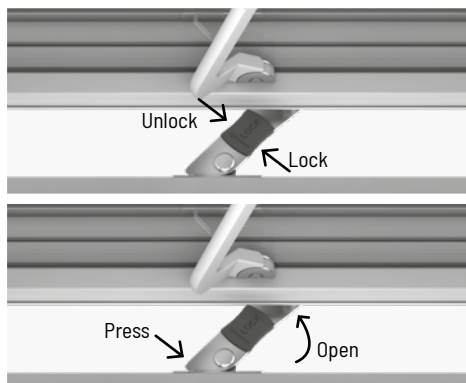

> **The opening restrictor** automatically engages when the sash is opened to approximately 10cm.

In ventilation position. To lock the window in the ventilation position, push the red locking plate outwards until a click is heard. Before closing the window, push the red locking plate first (locked up).

To cleaning position. To open the window completely, pull it back slightly and detach the restrictor by pressing the edge so the restrictor turns slightly outward while the window is opening.



> **Click vent.** The click vent is fitted within the frame and provides background ventilation. The vent is opened by pressing one or both ends marked with strokes.

> At VELFAC.co.uk and YouTube, you can watch a video about how to operate the opening restrictor.



> **The PN-fitting** makes it difficult for unwanted guests to enter if the window is open. When opening the window, the arm is lifted and re-engaged when the required opening is achieved. The arm is raised to a vertical position to disengage, allowing the sash to open fully.

N.B: Please note that some insurance companies will not cover losses from burglaries which have been committed when windows have been left in a ventilation position.

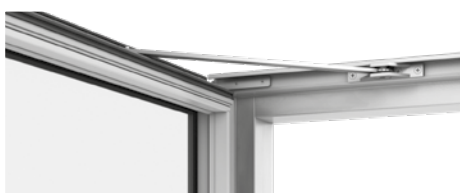

> **The friction arm** will retain the open window in any ventilation position in calm weather conditions. If it is really windy the ventilation position in the handle is to be used instead (see p. 18). The friction arms are adjusted by the factory to fit the size of the window. If the window opens too tight or too loose, the friction arm may be adjusted (see more by the relevant type of window).



> **Window stay.** The arm is fitted to the wood frame and when used, is hooked into an eyelet on the sash to achieve an opening of approximately 130mm.



> **The lockable restrictor** limits the opening of the sash to 1.5-10cm. It is possible to disengage the restrictor by turning the lock through 90° with a 5mm hex key. Now the restrictor arm may be pushed out of the guide rail. The lock must always be re-engaged after use. The guide rails should frequently be cleaned from dirt.

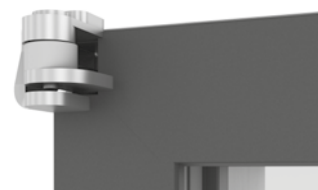

> **The 180° hinge** allows casement doors to open 180°. An adjustable friction arm with a light friction will stop the sash in maximum opening position ensuring, that the casement door will not hit against the wall. The 180° hinge is not available in combination with handle operated brake or 24mm threshold.

Other accessories

Internal sash for VELFAC 200 windows

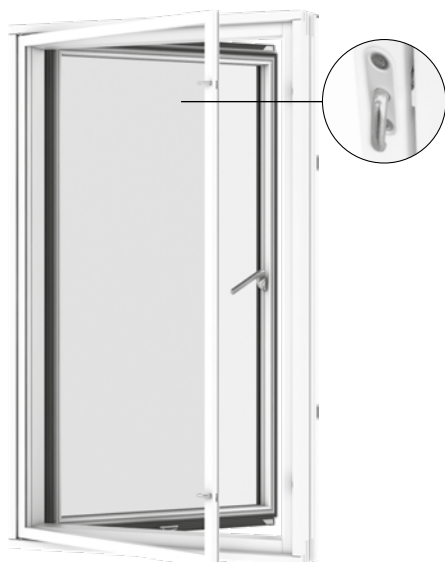

Sidehung

The internal sash of a 2+1 window significantly improves acoustic and thermal properties. In order to constantly maintain this improvement, the internal sash must remain closed. It can be sidehung or tophung and can be equipped with either handles or screws depending on whether the sash will be opened in daily use or only for cleaning purposes.

The sidehung internal sash is opened by turning the small handles approx. 90° and pulling the sash inwards. The sidehung sash can be opened for both ventilation and cleaning.

The tophung internal sash should only be opened for cleaning purposes and should be completely dismantled before commencing (1). In order to remove the tophung sash, loosen the screws approx. 90°, press in the top right hinge pin (2) and tip out the sash (3) - this operation will require 2 people.

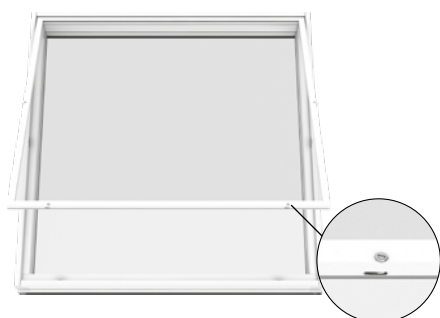

Tophung

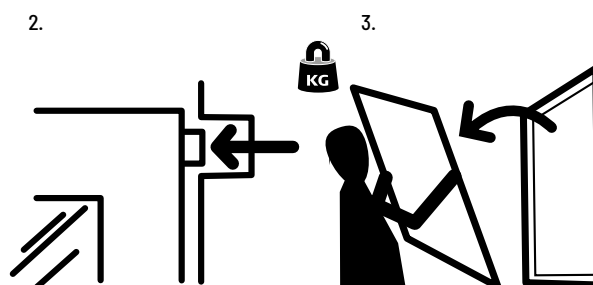
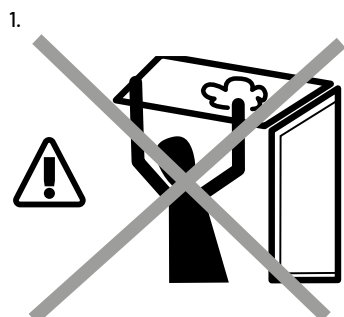
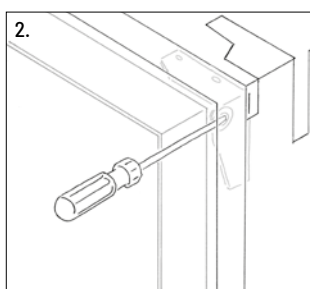

VELFAC Ribo Topguided window



This window is opened by turning the handle to a vertical position and pushing the sash outwards. Opening the window will provide a ventilation gap at the head.

Adjustments. The friction arms can be adjusted by turning the friction screws at the sides of the frame using a 4mm hex key.(1). Each screw is adjusted equally to keep the sash level and square.

If you need to adjust the position of the sash within the frame, use a 5mm hex key and turn the adjustment screws (2) found on either side of the sash and move the sash up or down as required ($90^\circ = 2\text{mm}$).

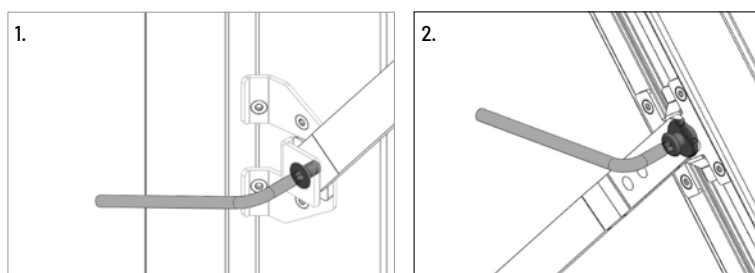

VELFAC Ribo Fixed light / Fixed casement

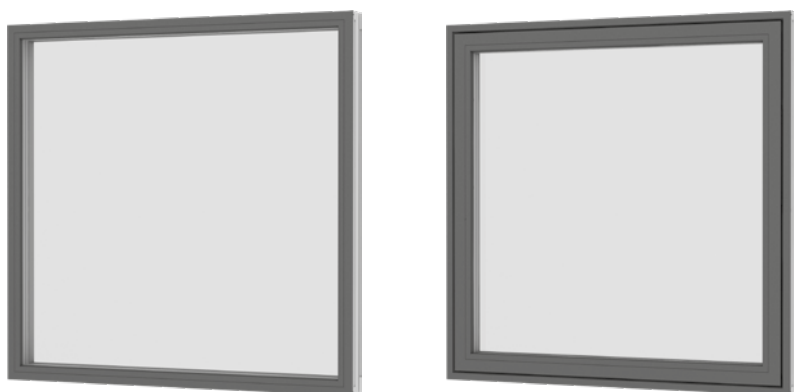

A fixed window cannot be opened and therefore requires no maintenance or adjustments of opening fittings.

VELFAC Ribo Sidehung window

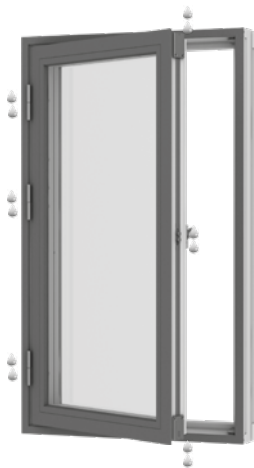

This window is opened by turning the handle to a horizontal position and pushing the sash outwards.

The sidehung window is supplied with a handle operated brake that can hold the window frame in any open position, up to 85°. The handle-operated brake is operated by turning the handle to a vertical position when you have opened the window to the point where you want to hold it. In very windy conditions, you must close the window or ensure that the window does not over extend and cause damage.

Double leafed windows can be supplied with different types of mullion - see page 30 for more information.

Adjustments. If you need to adjust the height of the sash within the frame, use a 5mm hex key and turn the adjustment screw in the bottom hinge to adjust the sash up and down as required (1). For sashes above 1200mm in height adjustments are required to all hinges.

To adjust the sash side to side use a 5mm hex key and turn both screws per hinge to adjust the sash left and right as required. (2). To avoid distortion of hardware adjust the screws equally in turn rotating a maximum quarter turn at a time.

The handle-operated brake can be tightened using a 2mm Allen key (3). Turn slightly clockwise to tighten the brake, 10-20° will usually be enough.

To support the closed sash and assist in functionality there is a sash lift pulley wheel (4) that can be adjusted up or down. To activate the door leaf should be opened, the exposed screw in the center of the wheel should be loosened using a 3mm hex key and adjusted up or down and tightened again. Check to ensure the wheel is supporting the window when in the closed position. In 2-leaf windows with rebated meeting style the secondary sash also has a wheel that should be activated and adjusted.

Care. The hinges require oiling using acid-free oil. In order to ensure the hinges are properly lubricated, the window should be opened and closed several times during and after oiling.

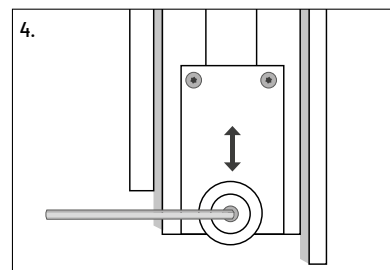
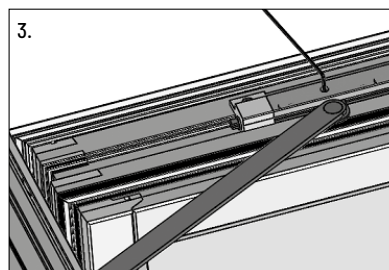
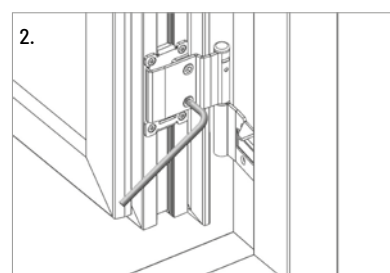
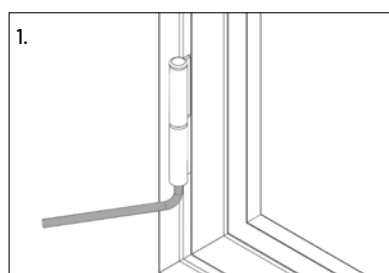

VELFAC Ribo Sideguided window

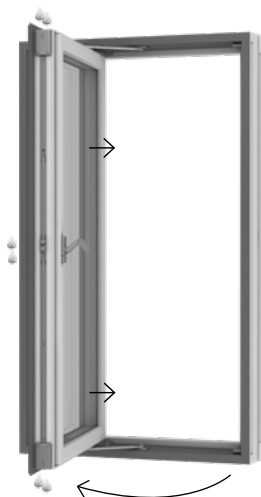

This window opens by turning the handle to a horizontal position and pushing the sash outwards.

Cleaning. When the sash is fully opened (90°), a gap is formed at the hinge side. This allows the external side of the sash to be cleaned from inside the building.

Adjustments. If you need to adjust the height of the sash within the frame, open the window to maximum position, and using 4mm hex key turn the set screw located at the top of the bottom hinge to adjust the sash up and down as required (3).

To adjust the sash side to side use a 4mm hex key and turn the adjustment cam screw at the top and/or at the bottom of the frame (4).

To support the closed sash and assist in functionality there is a sash lift pulley wheel (5) that can be adjusted up or down. To activate the door leaf should be opened, the exposed screw in the center of the wheel should be loosened using a 3mm hex key and adjusted up or down and tightened again. Check to ensure the wheel is supporting the window when in the closed position. In 2-leaf windows with rebated meeting style the secondary sash also has a wheel that should be activated and adjusted.

Care. Guide rails should be kept free of dust or dirt by cleaning with a soft brush or cloth (1 + 2). The guide rails should be sprayed with teflon-based lubricating oil or a similar product once a year, as a minimum (never all-round lubricating oil!).

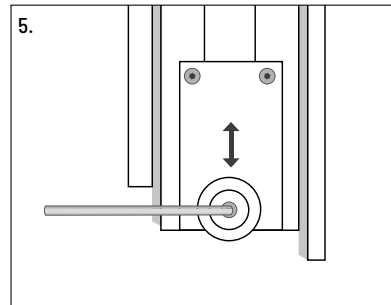
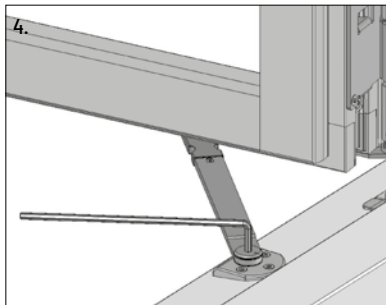
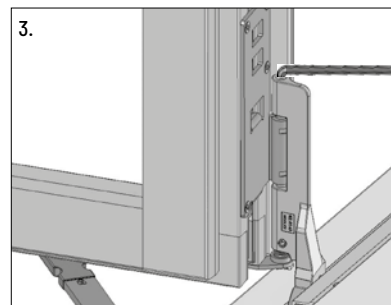

VELFAC Ribo Sidehung reversible window

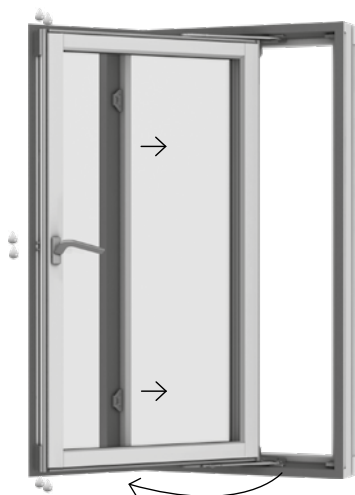

This window opens by turning the handle to a vertical position and pushing the sash outwards until the built-in safety restrictor engages at an opening of 5-10cm.

Cleaning. The external side of the window can be cleaned from inside the building by reversing the sash. Open the window until the restrictor is activated. Pull back the window slightly and detach the restrictor (1). Push the window outwards until fully reversed - DO NOT LEAN OUT while doing so. The sash is fully reversed when the cleaning catch engages to keep it in the cleaning position (2). Make sure the sash is fixed in cleaning position before starting to clean.

When the sash has been cleaned, first the cleaning catch then the safety restrictor can be disengaged: Pull back the window slightly and detach the cleaning catch (2), rotate the sash towards you until the handle is within reach - DO NOT LEAN OUT while doing so. Then detach the safety restrictor (1). The restrictor will automatically re-engage when the sash is closed. Never leave the window unattended while the restrictor is disengaged!

Adjustments. If you need to adjust the height of the sash within the frame, open the window to 90°, and using a 4mm hex key turn the set screw located at the top of the bottom hinge to adjust the sash up and down as required (4).

To adjust the sash side to side use a 4mm hex key and turn the adjustment cam screw at the top and/or at the bottom of the frame (5).

To support the closed sash and assist in functionality there is a sash lift pulley wheel (6) that can be adjusted up or down. To activate the door leaf should be opened, the exposed screw in the center of the wheel should be loosened using a 3mm hex key and adjusted up or down and tightened again. Check to ensure the wheel is supporting the door when in the closed position.

Care. Guide rails should be kept free from dirt (3). They should be sprayed with a **teflon-based** lubricant or a similar product once a year, as a minimum (do not use common mineral based oil).

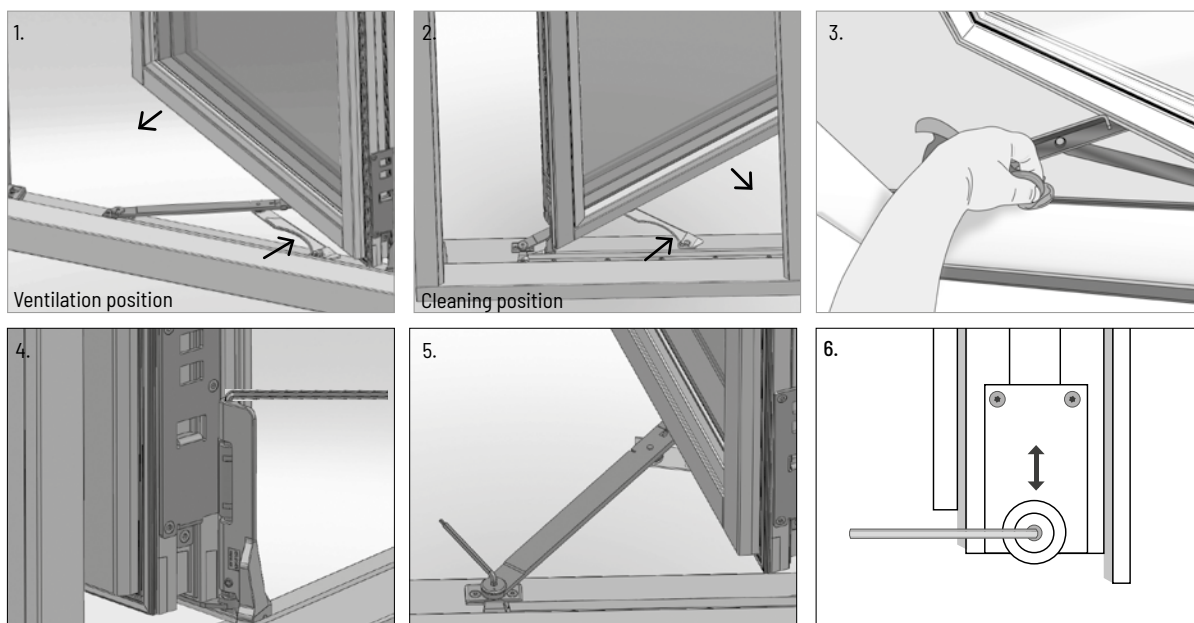

VELFAC Ribo Tophung reversible window

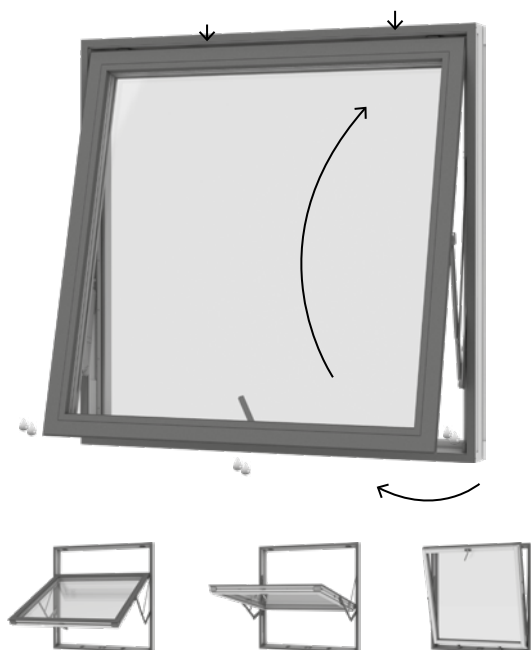

This window opens by turning the handle to a vertical position and pushing the sash outwards until the safety restrictor engages at an opening of 5-10cm.

Cleaning. The external side of the window can be cleaned from inside the building by reversing the sash. Open the window until the restrictor is activated. Pull back the window slightly and detach the restrictor (1).

Push the window outwards - DO NOT LEAN OUT while doing so. When pushed outwards, the top of the sash can be pulled gently downwards toward the bottom of the window. The sash is fully reversed when the cleaning catch engages to keep the sash in the cleaning position (2). Make sure the sash is fixed before starting to clean.

When the sash has been cleaned, the cleaning catch can be disengaged (3), it is placed 10-15cm from the bottom left corner of the window: Pull back the window slightly. Allow a finger to slide under the sash and lift the cleaning catch upward. Keep the catch up and push the window about 5cm upwards to release the catch. Now the bottom of the sash can be guided back towards the top. The safety restrictor will automatically re-engage when the sash is closed. Never leave the window unattended while the restrictor is disengaged!

Adjustment. If you need to adjust the position of the sash within the frame, use a 22mm open-ended spanner turn the adjusting rivet on both sides of the sash as required (5). Remove the plastic protection plate while adjusting.

Care. The guide rails of the friction arm should be kept free from dirt (4). They should be sprayed with a **teflon-based** lubricant or a similar product once a year, as a minimum (do not use common mineral based oil).

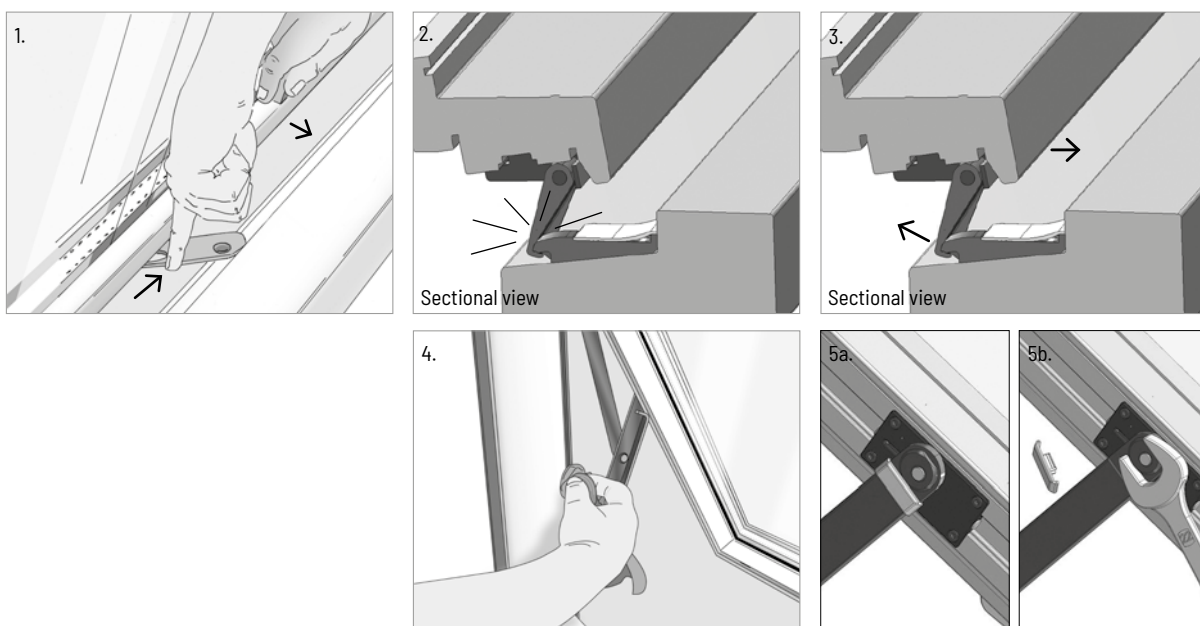

VELFAC Ribo Casement door

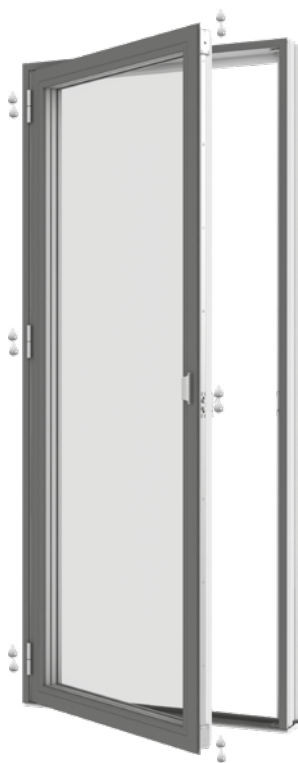

The casement door is opened by turning the handle to a horizontal position and pushing the door leaf outwards.

The door has a handle operated brake. At any opening position (10° - 85°) turn the handle down to a vertical position to activate the brake. To de-activate the brake, turn the handle to the horizontal position. In very windy conditions, you must close the door or ensure that the door does not over extend and cause damage.

2-leaf doors are supplied with a French casement mullion - see page 30 for more information.

Adjustments. If you need to adjust the height of the sash within the frame, use a 5mm hex key and turn the adjustment screw in all hinge to adjust the sash up and down as required (1).

To adjust the sash side to side use a 5mm hex key and turn both screws per hinge to adjust the sash left and right as required. (2). To avoid distortion of hardware adjust the screws equally in turn rotating a maximum quarter turn at a time.

The handle-operated brake can be tightened using a 2mm Allen key (3). Turn slightly clockwise to tighten the brake, 10 - 20° will usually be enough.

To support the closed sash and assist in functionality there is a sash lift pulley wheel (4) that can be adjusted up or down. To activate the door leaf should be opened, the exposed screw in the center of the wheel should be loosened using a 3mm hex key and adjusted up or down and tightened again. Check to ensure the wheel is supporting the door when in the closed position. In 2-leaf casement doors with rebated meeting style the secondary sash also has a wheel that should be activated and adjusted.

Care. The hinges require oiling using acid-free oil. In order to ensure the hinges are properly lubricated, the door leaf should be opened and closed several times during and after oiling.

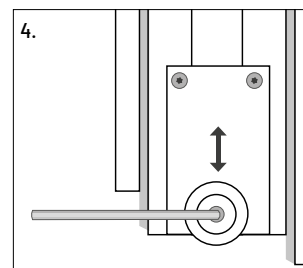
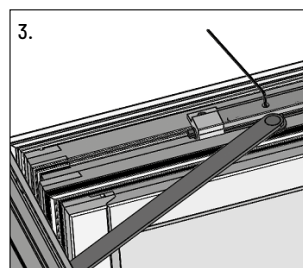
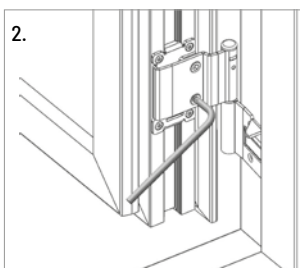
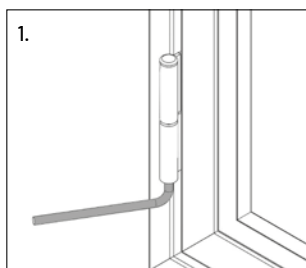

VELFAC Ribo Patio door



Available as inward or outward opening door

The patio door is opened by turning the handle to a horizontal position and pushing the door leaf outwards or inwards depending on door type.

The door has a handle operated brake. At any opening position turn the handle down to a vertical position to activate the brake. To de-activate the brake, turn the handle to the horizontal position.

2-leaf doors are with rebated meeting style. See page 30.

Adjustment. The door can be adjusted side to side by loosening the two hinge screws on the frame with 1-2 turns of a Torx 20 drive (1) and adjust by loosening or tightening the Allen screws (2) using a 3mm hex key.

The height of the door leaf may be adjusted using a 6mm hex key to turn the screw in the bottom of all the hinges (3) up and down as required (+/-2.5mm).

To adjust the closing pressure use a Torx 10 drive to loosen the screws and remove the cover plate from the striking plate, this will expose two pins which can be cut off (4).

Reinstate the coverplate. In double-leaf doors the closing pressure might be further adjusted by turning the striking plates (5) at head and threshold 90° clockwise or anticlockwise. At the threshold a coverplate needs to be removed before adjusting.

To support the closed sash and assist in functionality there is a sash lift pulley wheel (6) that can be adjusted up or down using a Torx 25 drive. To activate the door leaf should be opened, the exposed screws should be loosened so the wheel drops and becomes visible. The top screw should then be tightened and the door closed. Check to ensure the wheel is supporting the door when in the closed position. Open the door and tighten the remaining screw.

Care. The hinges, lock and closing points require oiling at least once a year with a teflon-based lubricating oil or a similar product. In order to ensure they are properly lubricated, they should be activated several times during and after oiling (7).

On inward opening doors, the external rainscreen (8) should at least once a year be oiled with silicone lubricant.

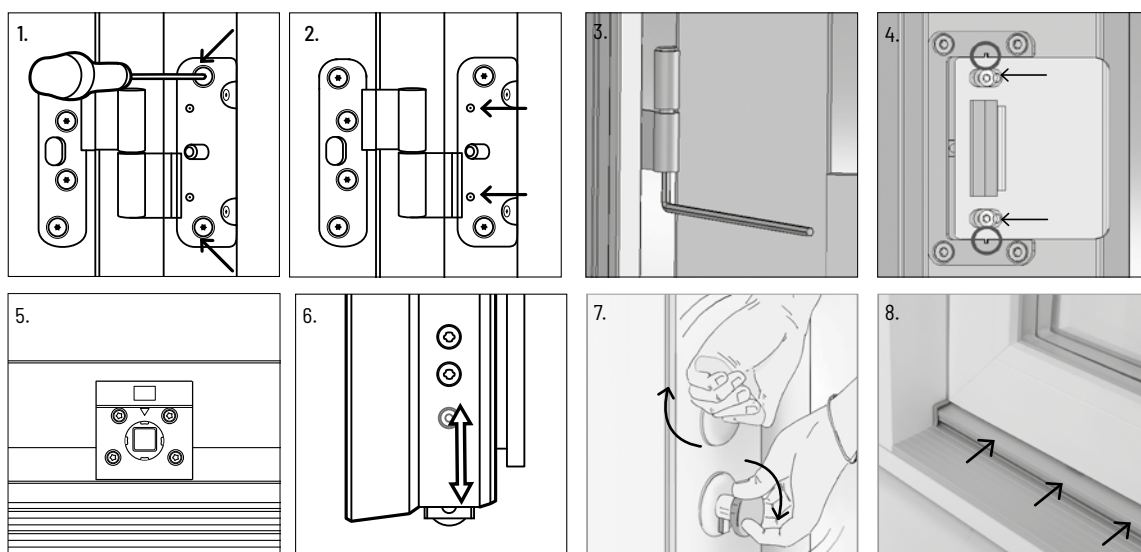

VELFAC Ribo Sliding door

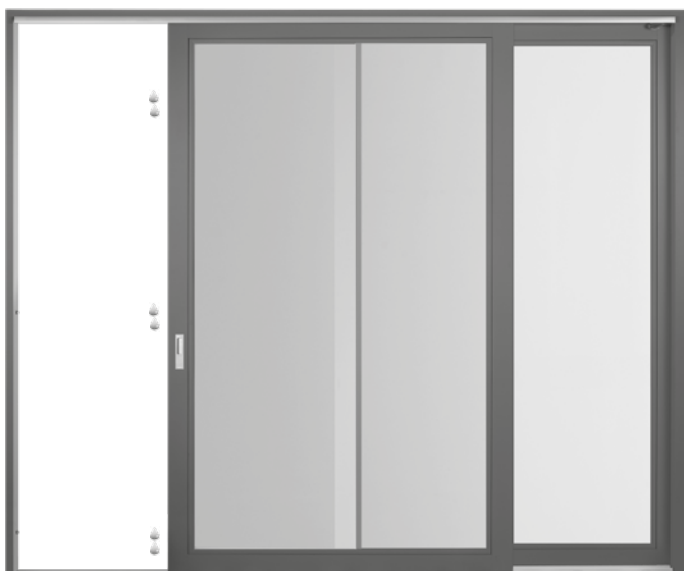

The sliding door is opened by turning the handle 180° down from (1) to (2). This lifts the door up, so it can be slid past the fixed part of the element. The sliding door is closed by sliding it completely in front of the opening and turning the handle up again (1).

Ventilation position. The door can be fixed in any position by turning the handle up (1). Be aware that however the handle must always be in the fully open position (2) while the door is operated, as the handle may otherwise damage the mullion.

Adjustments. The closing pressure (3) can be adjusted using a 9mm open ended spanner to turn the knobs at the closing side of the sliding door. The gasket pressure (4) can be adjusted using a 4mm hex key through the small holes positioned at the 'the mullion' on the external side of the opening sash.

Care. The sliding rails at the top and bottom must be kept free from dust and dirt with a cloth or soft brush (5). Gaskets and the steering mechanism at the top and bottom sliding rails should be sprayed with silicone once a year or as required. Spray the silicone onto a cloth and wipe to avoid getting silicone on the glazing.

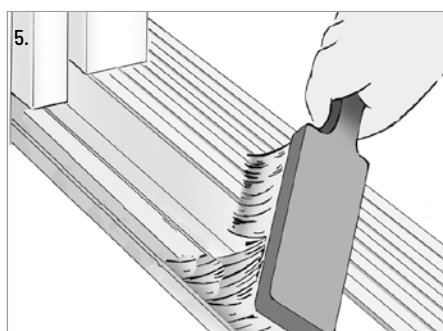
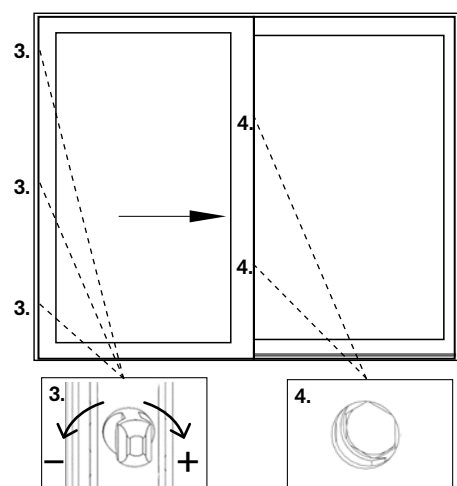

Handles, safety fittings and other accessories for VELFAC Ribo windows and casement doors

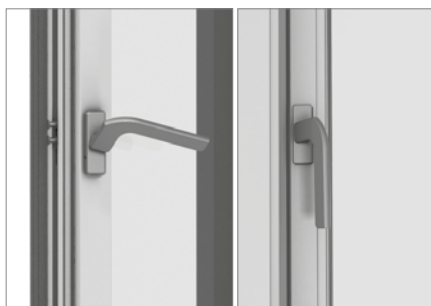
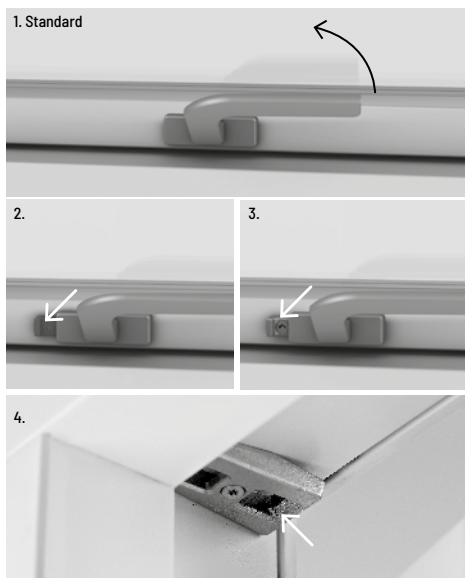

> The **handle-operated brake** can hold the sash in any open position from approx. 10-85°. The brake is activated by opening the sidehung window/Casement door to the desired position and turning the handle down to the vertical position.

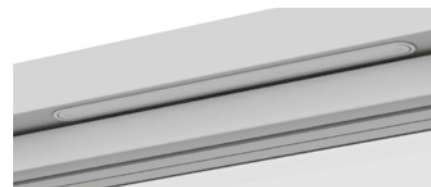

> The **click vent** is fitted within the frame and provides background ventilation. The vent is opened by pressing one or both ends marked strokes.



> The **opening restrictor** automatically engages when the sash is opened to approximately 3.5cm. To open the window completely, pull it back slightly and detach the restrictor by pressing the green button while opening the window.

> Espagnolette handle types:

1. The espagnolette handle is tipped upwards to open the window.
2. Espagnolette handles with safety-locks can only be opened when the button at the end of the handle is pressed while the handle is turned. The safety-lock will automatically re-engage when the sash is closed.
3. Espagnolette handles with locks are equipped with a small, removable key. Once unlocked the espagnolette can only be opened when the button at the end of the handle is pressed while the handle is turned.
4. A ventilation position is obtained by pushing out the window approx. 1cm and re-engaging the handle in the outer recess.

> **Care.** The bolts of the handle require oiling at least once a year, while operating the handle to ensure proper lubrication.



> The **friction arm** will retain the open window in any ventilation position in calm weather conditions. If it is really windy the ventilation position in the handle is to be used instead.

The friction arms are adjusted by the factory to fit the size of the window. If the window opens too tight or too loose, the friction arm may be adjusted (see more by the relevant type of window).



> The **PN-fitting** makes it difficult for unwanted guests to enter if the window is open. When opening the window, the arm is lifted and re-engaged when the required opening is achieved. The arm is raised to a vertical position to disengage, allowing the sash to open fully.

N.B: Please note that some insurance companies will not cover losses from burglaries which have been committed when windows have been left in a ventilation position.

> At Velfac.co.uk and YouTube, you can watch a video about how to operate the opening restrictor.

Mullions and French casements for 2-leaf windows and doors



Fixed mullion

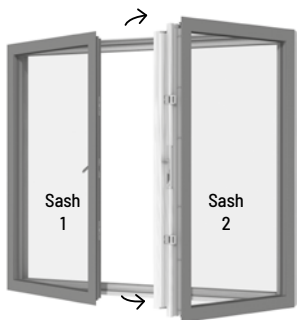

French Casement mullion

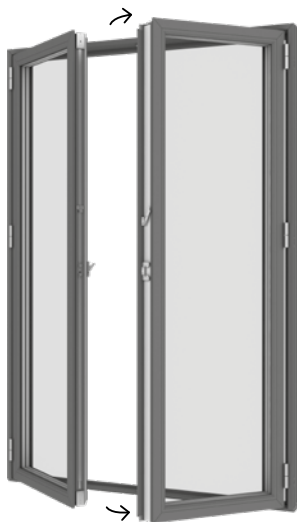

Rebated meeting style

A fixed mullion cannot be moved when both sashes are open.

The French Casement mullion is fixed to the leading edge of the Sash 2. Once Sash 1 has been opened, the mullion can be disconnected and Sash 2 subsequently opened. The mullion will move with the sash providing a clear opening for both sashes.

Depending on the window/door type, the mullion is disconnected by the mid-positioned flush bolt (A) or the handle with lock (B) in Sash 2.

- The flush bolt (A) is turned approx. 90° and Sash 2 is opened.
- The button at the end of the handle (B) is pressed while the handle is turned and Sash 2 is opened.

The French casement mullion must be re-engaged before closing Sash 1.

2-leaf windows/doors with rebated meeting style are operated by flush bolt (A).



Flush bolt for French Casement mullion and rebated meeting style.

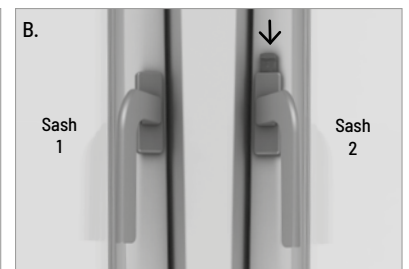

Lock button at the end of the handle in Sash 2.

VELFAC In Inward opening elements



For a detailed lubrication guide, see page 32.

> At Velfac.co.uk and YouTube, you can watch a video about how to operate the inward opening casement door.

The sections below describe the operation of an inward opening casement door. An inward opening window has similar operation.

To **open** an inward opening casement door turn the handle 180° from position (1) to position (3) and pull the sash inwards (up to 90°). Make sure that the sash does not blow open and hit the door casing.

Ventilation position. The door allows a ventilation gap at the top – turn the handle 90° from (1) to (2) and tilt the door inward.

To **close** an inward opening casement door, push the door frame against the casing at the top and at the handle, while turning the handle down to vertical position (1).

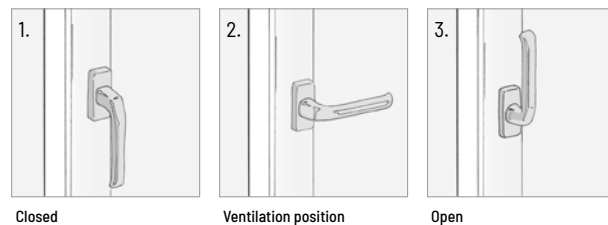

To fully open a **2-leaf casement door**, turn the handle from position (1) to position (3) and open the door. The flush bolt (9) in the middle of the slave leaf needs to be released before opening.

Check of closing function. This is the way the door should close (if not, the frame needs adjustment):

(4) In the side hung function, the sash should have strokes at the top and bottom as well as on the closing side.

(5) In the tilt function, the sash seal should first engage the frame in the topmost right corner opposite the handle.

Small windows without fail-safe.

Windows that are lower than 813mm have no fail-safe. Take extra care to fully close the smaller windows before turning the handle from position (2) to position (3). Push in at the top of the window sash with your other hand while turning the handle.

If the sash unhooks and becomes inoperable, you can put it back into place by turning the handle vertically 180° (3). Then push the sash in at the top with your other hand and keep it in place while turning the handle down to vertical position (1).

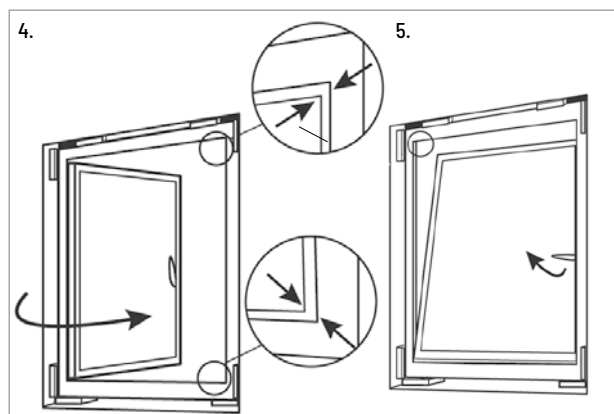

Adjustments.
See page 33.

VELFAC In Inward opening elements (continued)



Bottomhung

Sidehung

Care. We recommend that all movable fittings on the **sash** be oiled at least once with a year with neutral oil. Make sure you move the parts so that the oil penetrates inside fully. (B)+(D).

Use the same occasion to thoroughly clean all of the fittings on the **frame**, e.g. by sweeping them with a brush (C).

See the illustrations below.

A **mahogany bottom frame** of a balcony door can possibly be treated with a raw linseed oil without colour pigmentation.

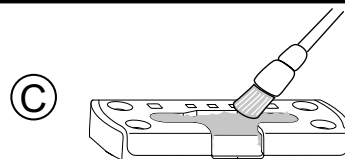
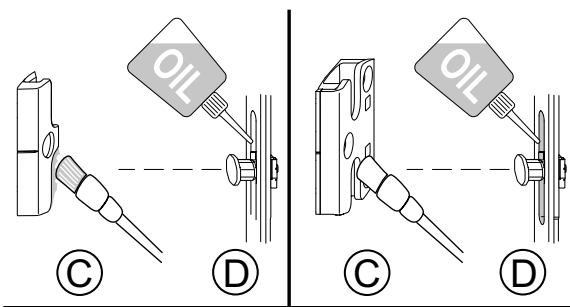
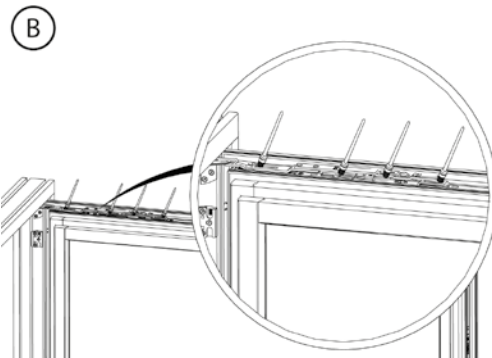
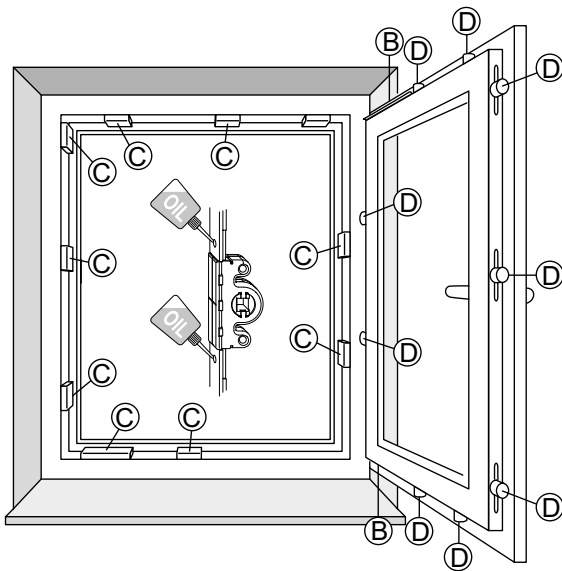

Handles for VELFAC In inward opening elements



standard

with lock

with safety-lock

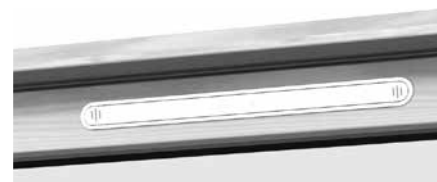

> **Click vent.** The click vent is fitted within the sash and provides background ventilation. The vent is opened by pressing one or both ends marked with 3 strokes.

> **Operation.** The handle has 3 positions: Closed, open and ventilation position (see page 31).

- **Handle with lock** can in closed condition be locked with a small, removable key.
- **Handle with safety-lock** can only be opened when the button above the handle is pressed downwards while turning the handle. The safety-lock will re-engage when the window/casement door is closed.

> At Velfac.co.uk and YouTube, you can watch a video about how to operate the espagnolette handle with safety-lock.

Release of a standing sash in a 2-leaf door (6). Press the lock button (A) in while opening the flushbolt (B) (approx. 135°). The standing sash can now open.

Adjustments: please see illustrations 7-9.

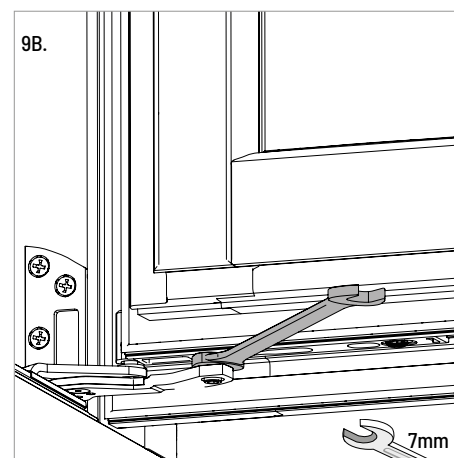
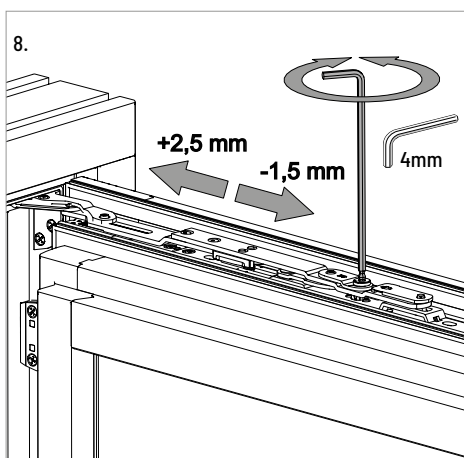
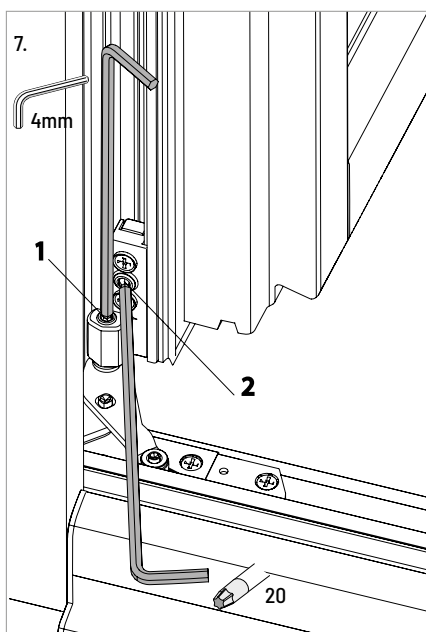
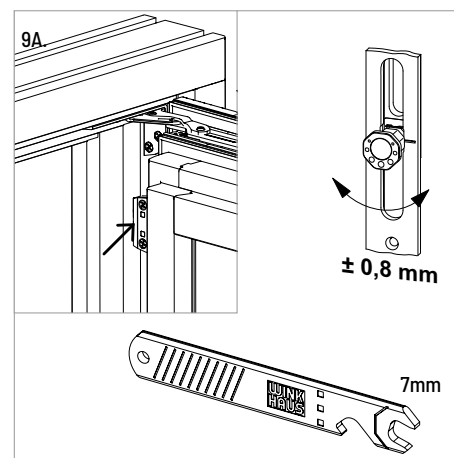
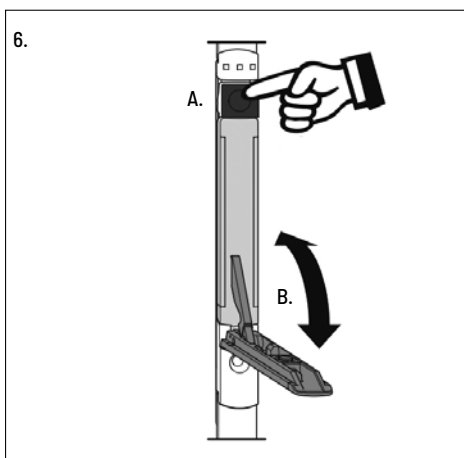

7. Adjustment at the bottom

1. Vertical adjustment of sash (+2.0mm/-1.5mm)
2. Sideways adjustment of sash (+2.5mm/-1.5mm)

8. Adjustment at the top

Sideways adjustment of sash (+2.5mm/-1.5mm)

9. Adjustment of closing pressure

- 9A Turn the locking mechanism at the top (+/- 0.8mm)
- 9B At the bottom (+/- 0.8mm)

VELFAC Ribo Entrance door



Inward opening glazed and panelled door



Outward opening glazed/panelled door

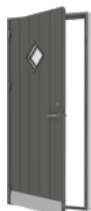

Outward opening flush door

The entrance door is by default delivered with 3 closing points. The top and bottom closing points are activated when the handle is lifted after closing the door. Equally the handle must be lifted before turning the key or thumbturn. The door is also available with a 1 closing point solution.

2-leaf doors are with rebated meeting style. See page 30.

Adjustment. The door can be adjusted side to side by loosening the two hinge screws on the frame with 1-2 turns of a Torx 20 drive (1) and adjust by loosening or tightening the Allen screws (2) using a 3mm hex key.

The height of the door leaf may be adjusted using a 6mm hex key to turn the screw in the bottom of all the hinges (3) up and down as required (+/-2.5mm).

To adjust the closing pressure use a Torx 10 drive to loosen the screws and remove the cover plate from the striking plate, this will expose two pins which can be cut off (4). Reinstall the coverplate. In double-leaf doors the closing pressure might be further adjusted by turning the striking plates (5) at head and threshold 90° clockwise or anticlockwise. At the threshold a coverplate needs to be removed before adjusting.

To support the closed sash and assist in functionality there is a sash lift pulley wheel (6) that can be adjusted up or down using a Torx 25 drive. To activate the door leaf should be opened, the exposed screws should be loosened so the wheel drops and becomes visible. The top screw should then be tightened and the door closed. Check to ensure the wheel is supporting the door when in the closed position. Open the door and tighten the remaining screw.

Care. The hinges, lock and closing points require oiling at least once a year with a teflon-based lubricating oil or a similar product. In order to ensure they are properly lubricated, they should be activated several times during and after oiling (7).

On inward opening doors, the external rainscreen (8) should at least once a year be oiled with silicone lubricant.

The external side of the flush door leaf must be painted with 100% water-based acrylic paint at least every three years to maintain the finish. More often if the door is exposed to the weather, and immediately if damage occurs to the surface.

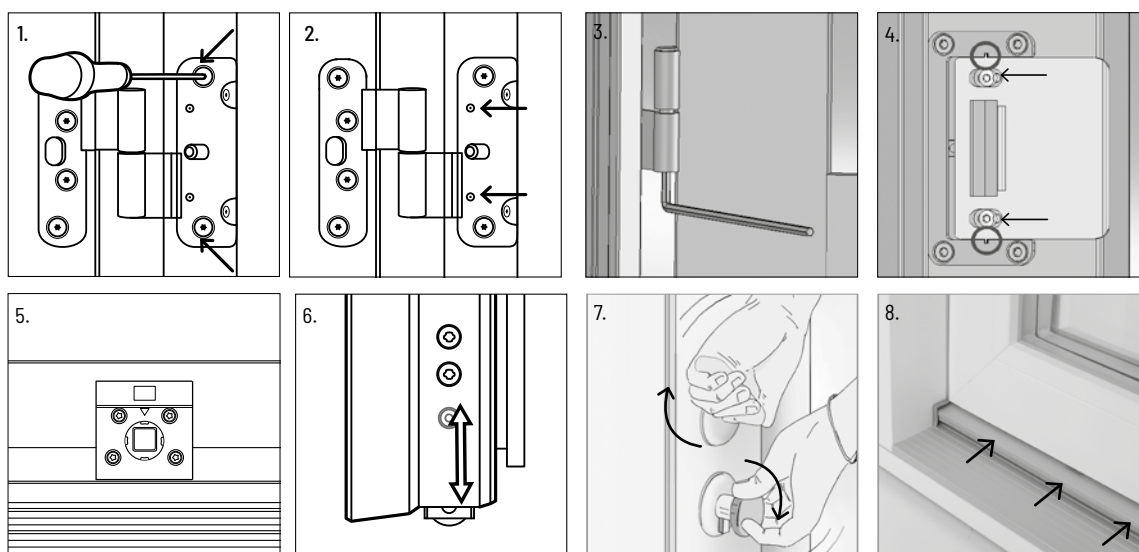

VELFAC Fire element

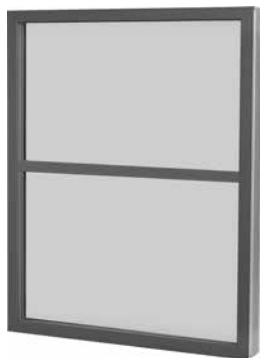

The fire element is fixed and should therefore neither be operated, lubricated nor adjusted.

Subzero temperatures: If the fire element is briefly exposed to freezing temperatures during storage and installation, the glazing may turn milky white for a while. This will disappear again, but it may take months to do so.

If the fire element is exposed to freezing temperatures for a long time, for example in an unheated summer house during a harsh winter, the fire glazing can suffer permanent damage.



Official Police Security Initiative



The mark of responsible forestry
FSC® C101947

Please ask for our FSC-certified products.

VELFAC
by DOVISTA UK Limited
T: 01480 759 510
service@dovista.com
www.VELFAC.co.uk

