

# Installation and Adjustment Guide

September 2023



➤ Check Health and Safety regulations for correct handling.

**VELFAC®**  
WINDOWS FOR LIFE

# Contents – General Installation Guidelines & Best Practice

<b>GENERAL</b> <b>Installations Guidelines &amp; Best Practice</b>  <b>Applicable in Connection with Installation</b>	Reception and Storage of VELFAC elements	4-5
	Installation of VELFAC elements	6-22
	- General Guidelines	6-7
	- Fixing – General Principles	8-11
	- Mandatory Packing Points	12
	- Dead Load Packing Guidance	13-14
	- Additional Packing + Final Fixing	15
	- Couplings Guidance & Principles – VELFAC 200	16-18
	- Couplings Guidance & Principles – VELFAC Ribo	19-20
	- Sealing Solutions – General Principles	21
	- Sealant Application – Do’s and Don’ts	22
	- VELFAC 200 Windows, Installation Best Practice	23
	- VELFAC 200 Windows + Casement Door, Installation Tips	24-25
	- VELFAC 200 Sliding Casement Door	
	- With 24mm Threshold, Installation Best Practice	26-29
	- With 24mm Threshold, Installation Tips	30-47
	- With 70mm Threshold, Installation Best Practice	48-50
	- With 70mm Threshold, Installation Tips	51-56
	- VELFAC 200 Rainscreen Panels	57
	- VELFAC 200 Installation of Drip Flashing	58-59
	- VELFAC 200 Acoustic Trickle Vent (in Packer)	60
	- VELFAC 200 With Motor	61
	- VELFAC 200 + VELFAC Ribo Backboard for Panels	62-63
	- VELFAC Ribo Doors, Fixing Methods	64-65
	- VELFAC Ribo Doors, Installation Best Practice	66
	- VELFAC Ribo Doors, Installation Tips	67-68
	- VELFAC Ribo Sliding Door, Installation Tips	69-71
	- VELFAC Ribo Windows + Casement Door Installation Tips	72
	- VELFAC Ribo Acoustic Trickle Vent (in Packer)	73
	- VELFAC Aluminium Door, Installation Tips	74
	- VELFAC In, Inward Opening, Mandatory Packing Points	75
- VELFAC In, Inward Opening, Installation	76-77	
- VELFAC Fire, Installation	78	

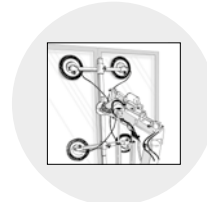

Click and go to Installation

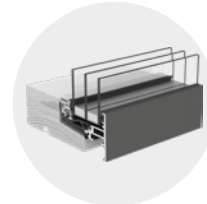

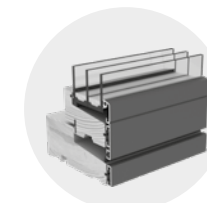

Click and go to VELFAC 200

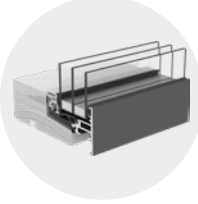
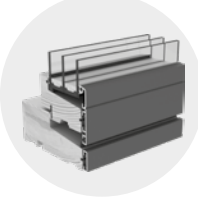

Click and go to VELFAC Ribo

# Contents - Desashing & Adjustment Guide + Glass replacement

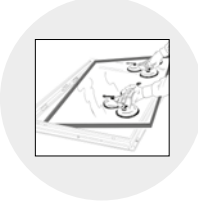
<b>VELFAC 200 Windows + Casement Doors</b>	General information about the VELFAC systems	79		<a href="#">Click and go to VELFAC 200</a>
	Sidehung window	80		
	Sideguided window	81		
	Fixed casement	82		
	Glass to glass corner window	83		
	Topguided window	84-85		
	Tophung reversible window	86-87		
	Tophung window	88		
	Bottomhung window	89		
	Casement door	90-91		
	Sliding casement door, 24mm threshold	92-97		
	Sliding casement door, 70mm threshold	98-103		
	Ventilated panel	104		
	With internal sash	105		
	With 180° hinge for casement door	106		
<b>VELFAC Ribo Windows + Casement &amp; Patio Doors</b>	Sidehung window	107		<a href="#">Click and go to VELFAC Ribo</a>
	Sideguided window	108-109		
	Sidehung reversible window	110-111		
	Topguided window	112		
	Tophung reversible window	113		
	Casement door	114		
	Patio door	115		
	Sliding door	116		
<b>VELFAC Entrance Doors</b>	VELFAC Ribo entrance door in wood/aluminium	117		<a href="#">Click and go to VELFAC Entrance doors</a>
	VELFAC Aluminium door with barrel hinges	118-119		
	VELFAC Aluminium door with claw hinges	120-121		
<b>VELFAC In Inward Opening</b>	Inward opening window/door	122-123		<a href="#">Click and go to VELFAC In</a>
<b>Glass Replacement per System</b>	VELFAC 200	124-129		<a href="#">Click and go to Glass replacements</a>
	VELFAC Ribo	130-133		
	VELFAC In	134-137		
	VELFAC Aluminium Doors	138		

## Reception and storage of VELFAC elements

### Warranty Advice

To maintain the Product Warranties provided by VELFAC careful consideration should be given to the content of the guidelines and information contained within this document. Failing to adhere to the instruction given may see functionality and longevity of the product affected and warranties rescinded.

Below is a list of key consideration points highlighted in this document. Should you require any further information please contact your Project Coordinator at 01480 759 510.

### Delivery Vehicles

All deliveries are made on articulated curtain-sided vehicles unless specific arrangements are made when placing your order.

Please consider access restrictions when selecting your mode of delivery. If an alternative delivery vehicle is required, please contact your VELFAC appointed contact.

All pallets will be delivered to ground only by VELFAC Logistics Partner. The methodology for this will depend on the type of vehicle being used for transportation.

Please see the different delivery vehicles we have available:

### Receipt & Delivery Advice

VELFAC product is delivered on non-returnable timber pallets with the maximum number of elements being governed by configuration, weight, and size.

From placement on the ground further movement and methods become the responsibility of the customer or the customer representative.

Careful consideration should be given to ensure the pathway to point of installation is maintained and that suitable equipment is readily available to allow movement of pallets / individual elements and minimize the risk to health safety and wellbeing of those undertaking this action.

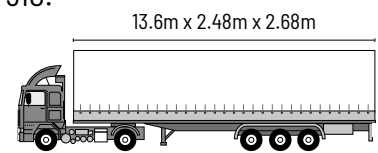

Articulated fixed and sliding roof

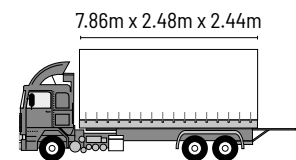

Rigid Side with Tail Lift

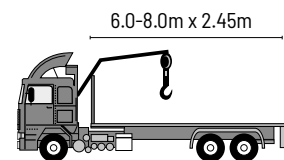

Flat bed with HIAB



Please follow the instructions in the guides in order to uphold the product warranty

## Reception and storage of VELFAC elements

### Product Storage Advice

All VELFAC products should be stored in a fully enclosed internal environment. Pallets must sit on solid level ground with enough footprint room to safely access the elements as and when required

If internal space is unavailable and there is a requirement to store product externally the requirement for a solid level ground substrate remains.

To protect the product from exposure to adverse weather conditions and or over exposure to UV light all pallets should be covered with a lightweight breathable cover which must be non-transparent and waterproof.

The cover must completely cover the top and sides of the delivered product and there must be sufficient clearance under the pallet to provide free air circulation.

VELFAC elements should be stored outside for a maximum period of **ten days** from receipt of delivery.

Improper storage that results in VELFAC elements being exposed to moisture for any period, may damage the surface of the wood components and affect the functionality of the windows and doors.

Failing to adhere to the guidance above may see product warranties rescinded.

For further guidance please address any further queries to your DOVISTA UK point of contact.



Correct storage



Incorrect storage

Please follow the instructions in the guides in order to uphold the product warranty

# Installation of VELFAC elements - General Guidelines

## Handling / Distribution

The weight of each individual element is indicated on a factory applied label generally positioned on a jamb location.

It is strongly recommended that all elements are moved / distributed in a vertical position i.e. bottom of the frame facing downwards.

Pallets should not be underslung, if distribution is by Tower Crane additional components will be required i.e., crane forks or spreader bars. Other methods of distribution are pallet truck and forklift both being operated by competent persons. When using straps, protect elements by using wear sleeves.

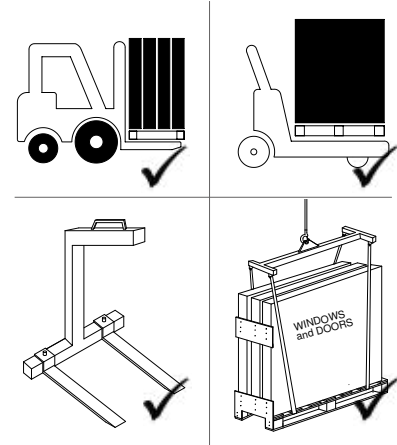

## Installation when?

Installation of VELFAC products should not commence until the building has a watertight roof and wall structure in place. To proceed without may lead to the moisture content of the timber components exceeding acceptable limits.

Immediately after installation of the windows, unintended moisture absorption by the wooden parts, (including moisture from the building itself - condensation), must be prevented by application of sealant around the windows, or otherwise.

If, due to build sequence it is not possible to immediately apply the primary seal consideration should be given as to how to prevent inadvertent exposure of the timber sections to high moisture contamination, this could be achieved by the application of a semi rigid sheet material.

## Useful Tips

All products are delivered factory glazed. Dependent on size and weight it can be beneficial to remove the aluminum section and glass from the timber mainframe. This is a process known as de-sashing and will make the frame assembly lighter and easier to maneuver.

Instructions for the de-sashing of all opening configurations can be found in the De-sashing and Adjustment Guide.



Complete Installation



Additional protection due to build sequence

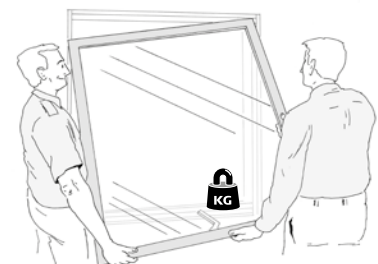

Please follow the instructions in the guides in order to uphold the product warranty

# Installation of VELFAC 200 elements - General Guidelines

## Useful Terminology

Below are section drawings for VELFAC 200 and VELFAC 200 ENERGY identifying the key system components.

In the event you need to communicate with VELFAC, using this terminology will aid understanding and prevent confusion.

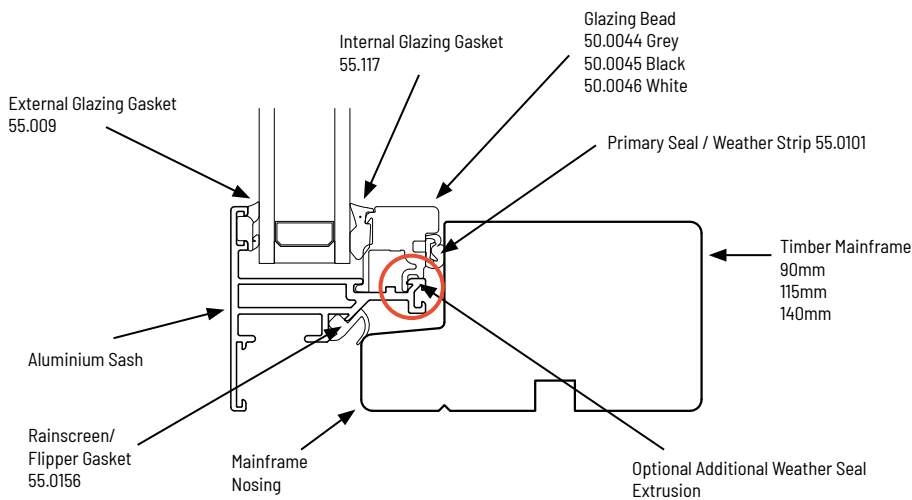

VELFAC 200 key system components

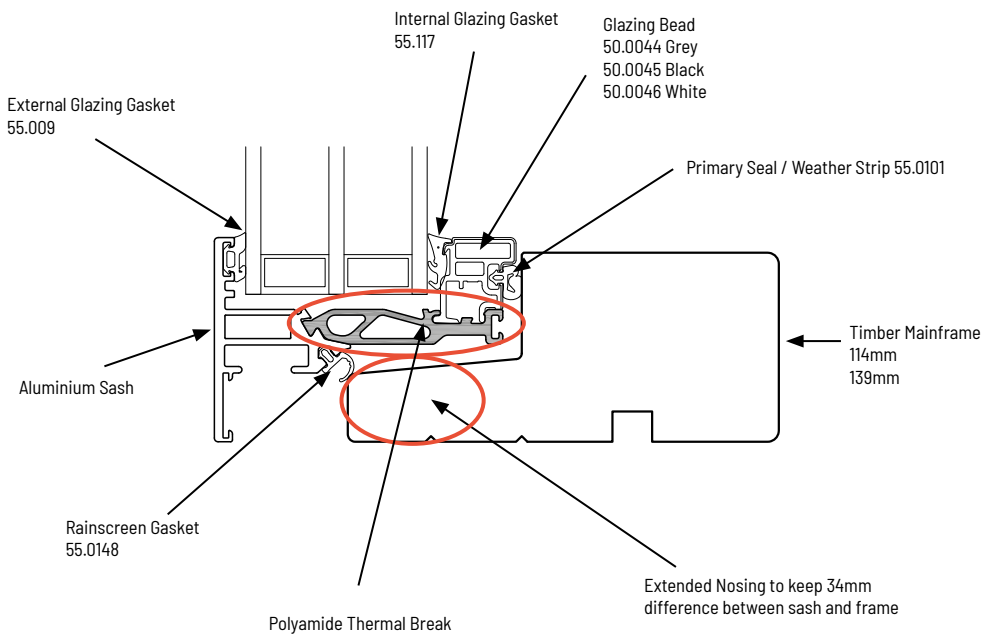

VELFAC 200 ENERGY key system components

**VELFAC 200 Fixing Methods**

There are two fixing applications that can be used for the installation of the VELFAC 200 window system, these are:

**Through frame** into a solid substrate using a compatible suitably sized fixing (Image 1).

**Lug / bracket fixed** into a solid substrate using a compatible suitably sized fixing (image 2).

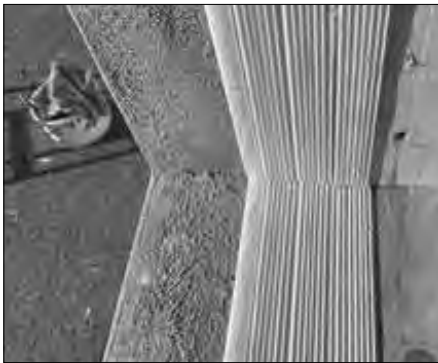

**Load bearing structure.** When using either form of fixing application it is imperative that the substrate being used as a fixing ground is suitable load bearing structure.

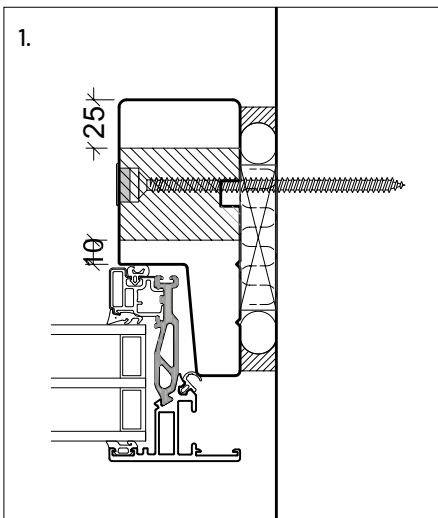

**1. Through frame fixing VELFAC 200 elements.**

When through fixing a frame to the surrounding structure, or to another frame, a 14mm circular hole should be cut into the frame using an auger bit or a spade bit to a depth of between 10mm and 15mm.

A clearance hole then needs to be drilled through the centre of the 14mm hole using a suitably sized HSS drill bit. The relevant cover cap can be purchased from VELFAC.

PLEASE NOTE, a frame to frame fixing requires a 75mm long 6mm threaded counter sunk screw. When fixing to the structure the minimum size frame fixing that can be used is a 6mm threaded counter sunk screw at a suitable length. The maximum size frame fixing that can be used is a 10mm threaded counter sunk screw at a suitable length.

When undertaking this type of fixing application generally fixing locations are positioned central on the timber mainframe. If there is a requirement to set them off centre this can be done but fixing centres must sit a minimum 25mm in from the outer edge of the mainframe and minimum 10mm in from the inner face of the glazing bead.

Cover caps can be ordered in our After Sales webform



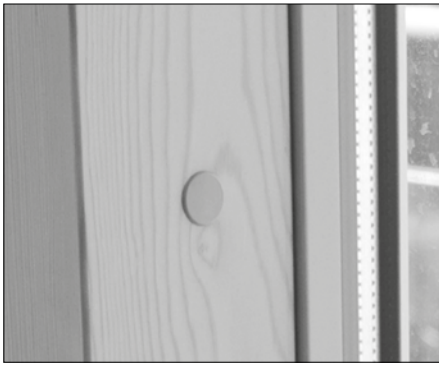

**VELFAC Cover caps assortment**

Cover caps can be purchased from VELFAC:

Colours:

White (NCS 0500), item no. 71.722

Light grey (NCS 1500), item no. 71.723

Dark grey (NCS 6502-B), item no. 71.732

Black (NCS 9000), item no. 71.724

Beige (NCS 3020-Y30R), item no. 71.725

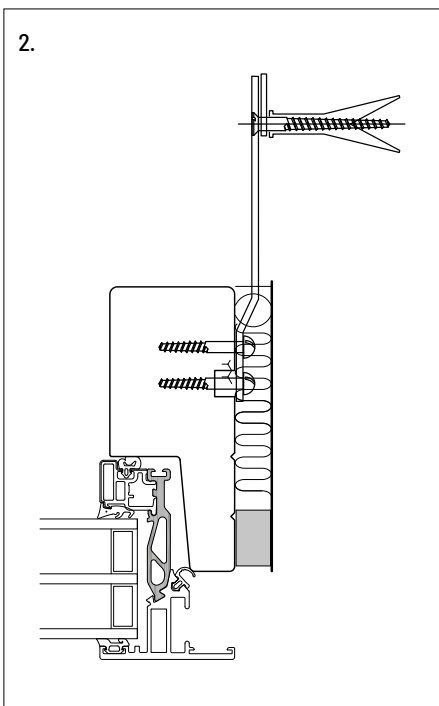

**2. Lug / bracket fixing VELFAC 200 elements.**

VELFAC lugs / brackets are available in multiple dimensions, this allows the correct choice to be made and will be dependent on the overall build thickness.

Other pressed metal lugs can be used, these should be manufactured from galvanised mild steel be a minimum thickness of 3mm and a minimum width of 50mm.

When using a lug / bracket fixing method the fixing must sit in board of the internal edge of the structure by a minimum 30mm.

Care should also be taken to ensure the fixing does not clash with joints of any type within the inner construction ie mortar joints in blocks etc.

Any and all structure must be robust in its construction and complete.

Any fixing applied should achieve a minimum embedment depth of 30mm and be sufficiently sized.

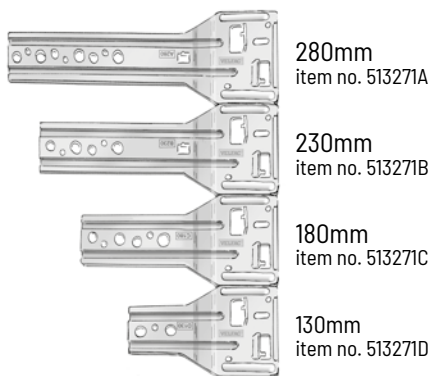

VELFAC standard twist in lug for Outward opening are available in 4 different lengths.

For further information we refer to our Installation Lug Design Guide in our Product database.

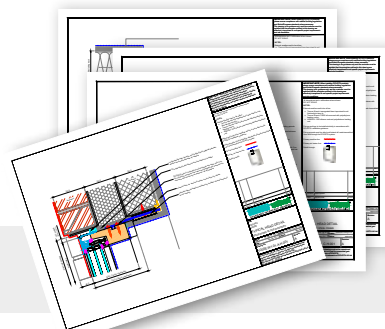

Find examples of installation drawings in our Product database

## Fixing - General Principles - 3/4

When using a through frame fixing method there are defined areas for this purpose dependent on the product being installed. Please see below the hatched area defines the fixing zones.

The dotted line defines the outer face of the external primary weather line, any seals applied must not project past this point.



VELFAC 200 ENERGY

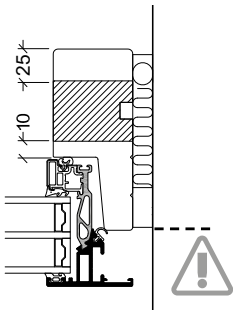

VELFAC 200 D6U

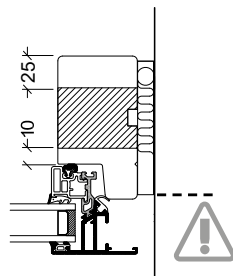

VELFAC Ribo outward opening windows and doors

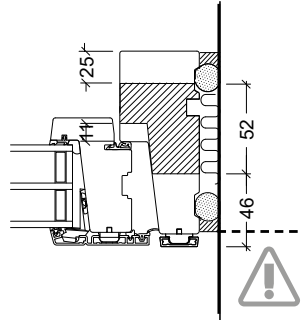

VELFAC Ribo inward opening doors

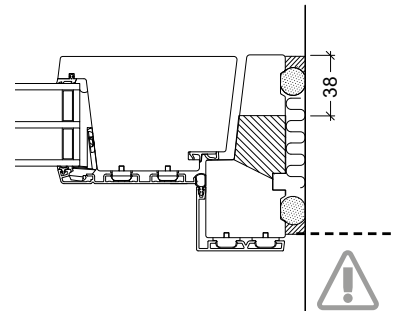

VELFAC 200 ENERGY skydedør

No sealant material beyond the dotted line.

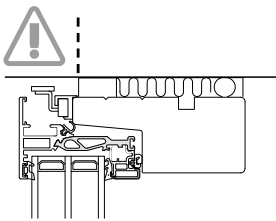

VELFAC Ribo fixed frame, 3-layer glazing

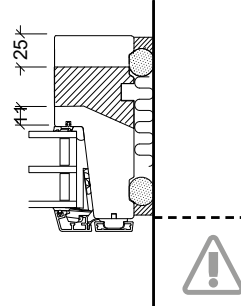

VELFAC Ribo fixed frame, 2-layer glazing

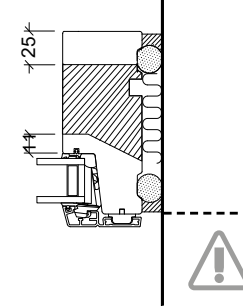

VELFAC Ribo sliding door fixed part, jamb

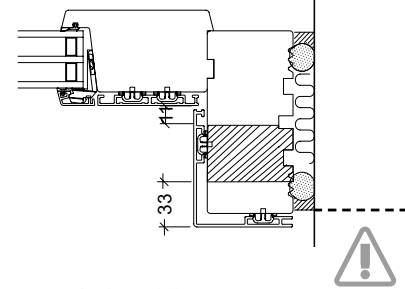

VELFAC Aluminium door outward and inward opening

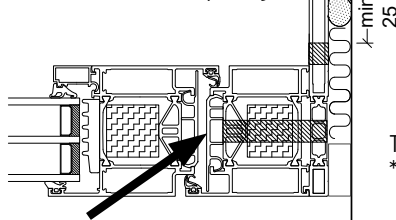

Tilt off the cover plate, before screw fixing the door.  
\*If supplied without VELFAC adaptor profile, see page 74.

VELFAC Ribo sliding door opening part, jamb

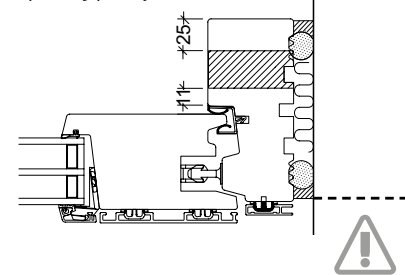

**Area for fixing.** Choose method A or B depending on element size:

**A** ⇒ Element  $\leq 1.5\text{m}^2$  and max. width  $\leq 1200\text{mm}$ :  
Permanent fixing area 1 or 2.

**B** ⇒ Element  $> 1.5\text{m}^2$  or max. width  $> 1200\text{mm}$ :  
1. Provisional, 2. Permanent.

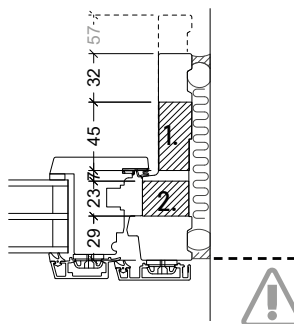

VELFAC In, 149mm + 174mm frame  
1. + 2. ⇒ see text

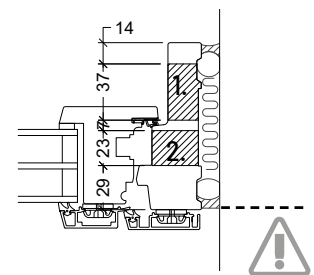

VELFAC In, 123mm frame  
1. + 2. ⇒ see text

## Fixing - General Principles - 4/4

### Window Element Fixing Location and Centres

Window elements up to 600mm wide do not require a fixing at head or cill. In these instances jamb brackets should be set 100-150mm from each corner. Further jamb brackets may be required to ensure fixing centres do not exceed 600mm.

Elements over 600mm wide require a minimum two fixing brackets at head and cill set equidistant from either end with other intermittent brackets if required to ensure centres are no greater than 600mm.

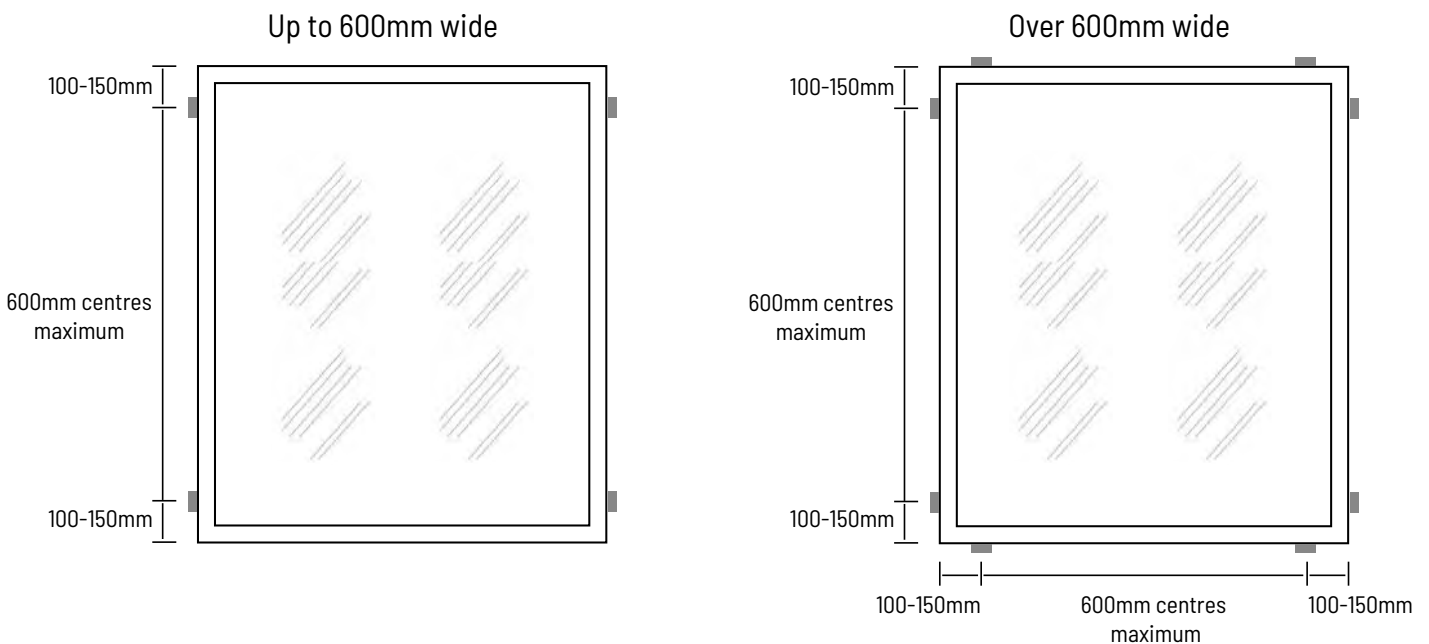

### VELFAC 200 Minimum and Maximum Set Back Dimensions

When considering the set back of the window i.e., the dimension from the face of the structure to the face of the aluminium sash, it is important to note that on a standard 100mm external brickwork reveal the maximum setback to allow for brickwork tolerances is 30mm.

- This is on the proviso that the build in situ is complete and in good order.
- Where reveals have been poorly constructed in order to gain a viable weather seal against the structure the window should be pulled forward.
- NB: Minimum set back is 20mm, if this setback dim does not allow for sealing against a solid substrate the build would need to be rectified.

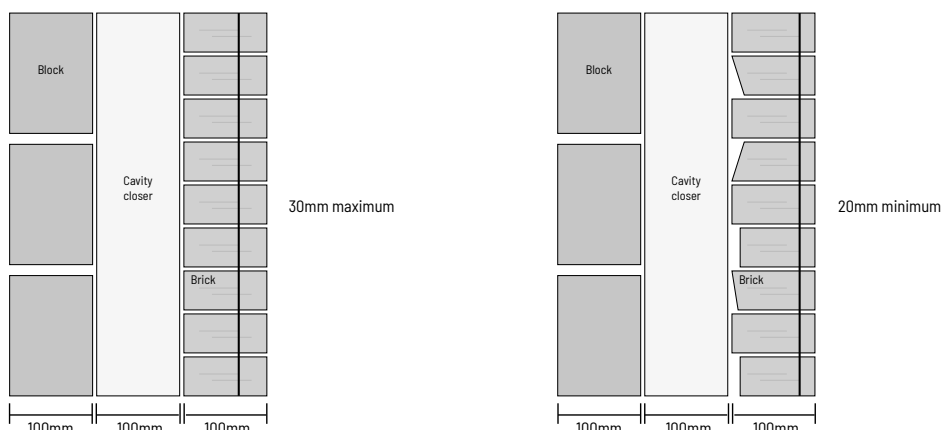

# Mandatory Packing Points

## VELFAC 200 Mandatory Packing Points

On a general 100 / 100 / 100 build with a standard window set back of 30mm all windows must be fully supported at each vertical load point with what is generally known as a bridging plate.

- For cavities up to 100mm, the bridging plates need to be a 3mm gauge steel, a minimum of 50mm wide and to a length that will bridge the cavity and sit on the external and internal structure by a minimum of 10mm in both instances ensuring it does not impinge on the external seal zone.
- They need to be placed below every vertical mullion or where two frames meet. For cavities larger than 100mm consider increasing to a 5mm gauge.
- NOTE: The illustrations are in relation to single storey dead loading only, an engineer will be required to calculate the support if over 1 storey.

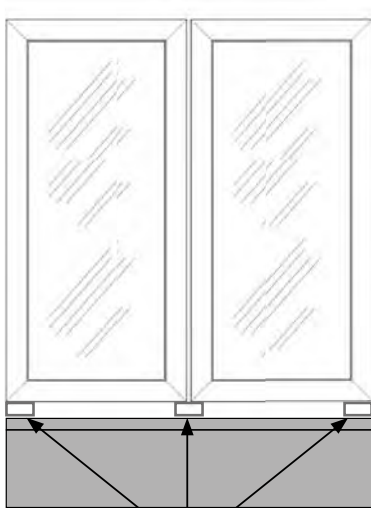

Bridging plate at each load point

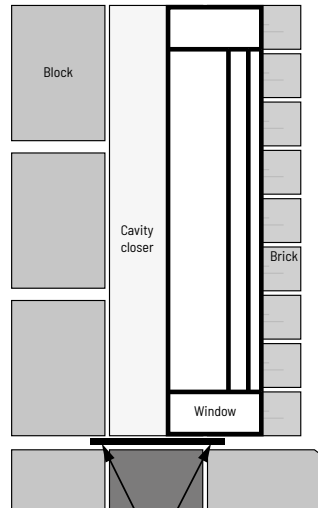

Bridging plate to span from out to in

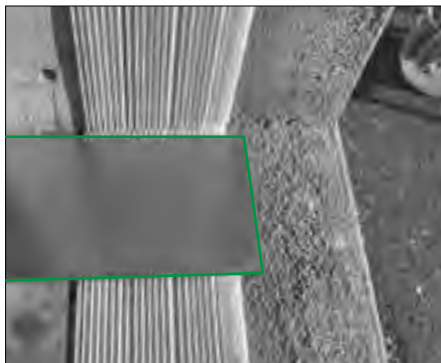

Bridging plate

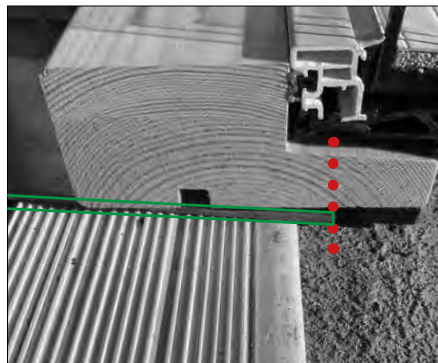

Bridging plate **correctly positioned** underneath the VELFAC 200 frame leaving room for minimum of 20mm sealing.

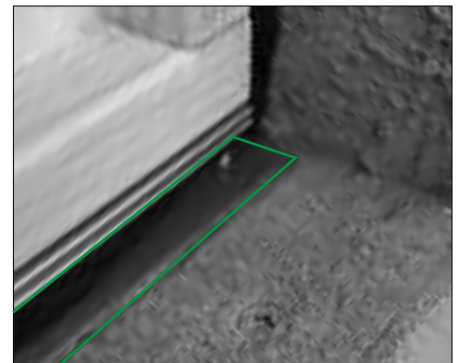

Bridging plate **incorrectly positioned** underneath the VELFAC 200 frame leaving no room for sealing.

# Dead Load Packing Guidance, 1/2

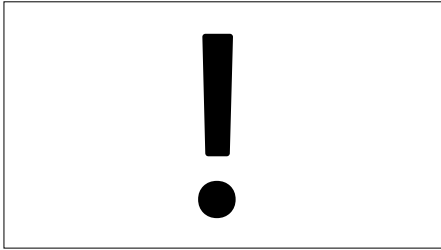

To ensure product functionality it is essential that the product is packed correctly and that the dead load implied is evenly distributed.

Below is an overview of the common thresholds within the VELFAC range detailing the position and depth of packing required in order to maintain product functionality. Packing material should be formed from metal, plastic or nylon composite material.

## VELFAC 200 windows, casement and sliding casement doors

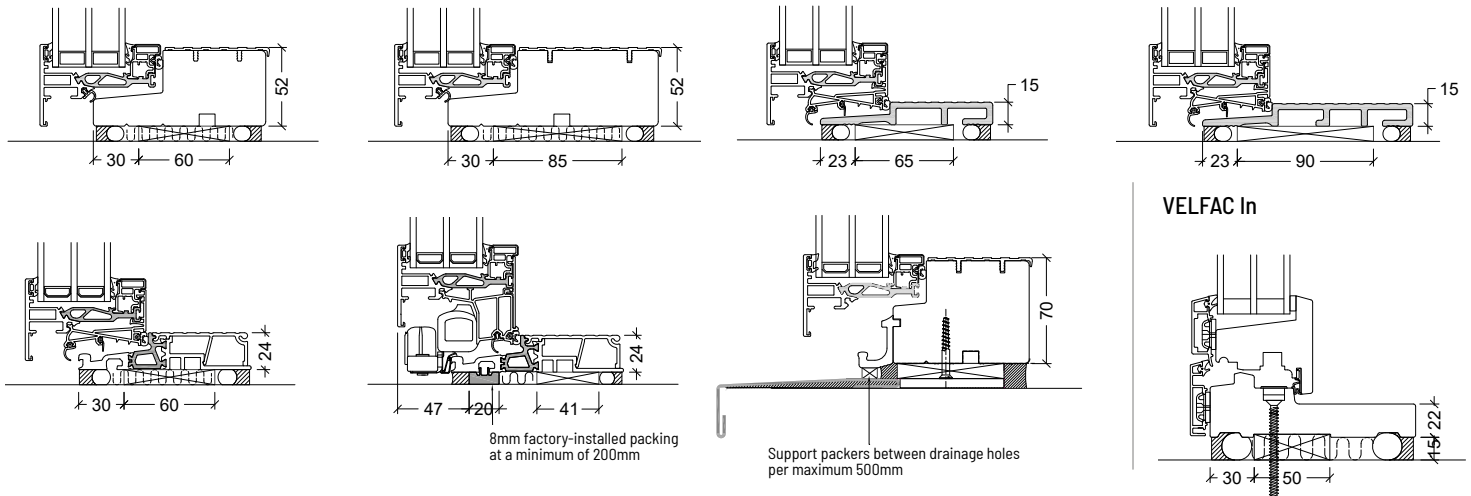

**IN ALL INSTANCES THRESHOLDS SHOULD ONLY BE SEALED USING SILICONE**

## VELFAC Ribo windows and doors

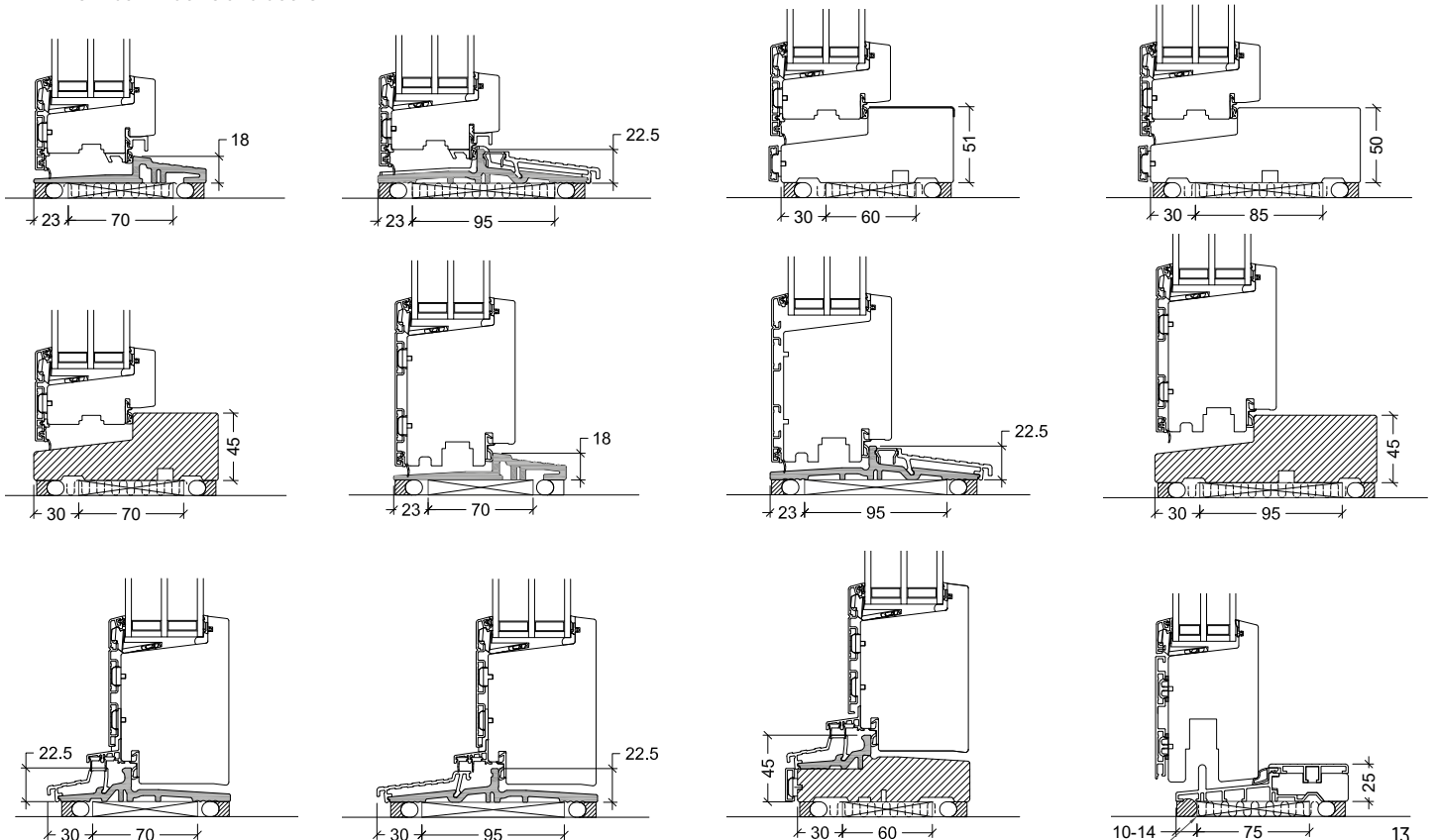

## Dead Load Packing Guidance, 2/2

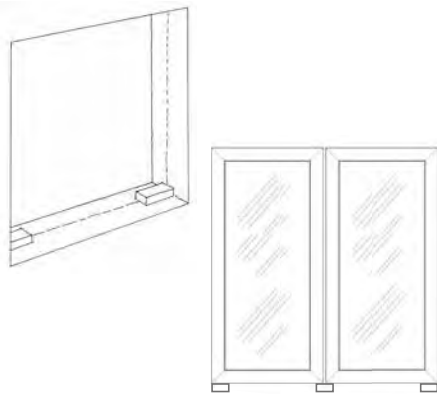

**The following shall apply to all windows and doors:**

- Permanent dead load packing must be positioned under each jamb and any further intermittent mullions.
- The packing should be positioned so as not to impinge on any seal zones.
- The packing material must be able to withstand exposure to moisture ie metal or nylon.

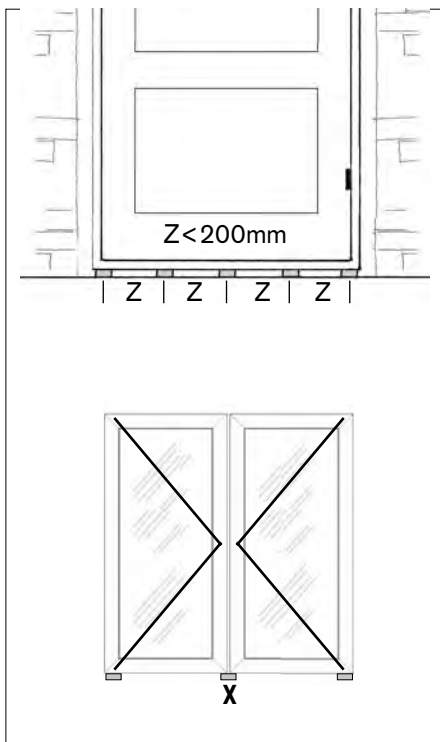

**For doors with composite or aluminium thresholds, the following guidance also applies:**

- The packing substrate directly below the threshold section must be complete and span the full width and depth of the threshold section.
- Thresholds will be packed at max 200mm centres (Z).
- Double door elements shall be packed directly under the striking plate (X).
- The optimal packing depends on the type of threshold, refer to images on previous page.
- Please note that when delivered the VELFAC Ribo threshold has a soft wood transport packer fitted to the underside of the threshold to prevent damage, this must be removed prior to installation (risk of rot).

**For installation of VELFAC In and VELFAC Fire elements, please find full installation details at page:**

- VELFAC In page 75-77,
  - VELFAC Fire element page 78,
- in the VELFAC Installation and Adjustment Guide**

## Additional Packing + Final Fixing

In addition to packing for dead load (A), all windows/doors should be packed between frames and masonry next to all hinges (B) and striking plates (C). This enhances security and helps prevent forced entry.

Side hinged opening functions must also be packed further behind all fixing points (D). This prevents the misalignment of sash elements. The larger the element, the more important the packing behind fixing points.

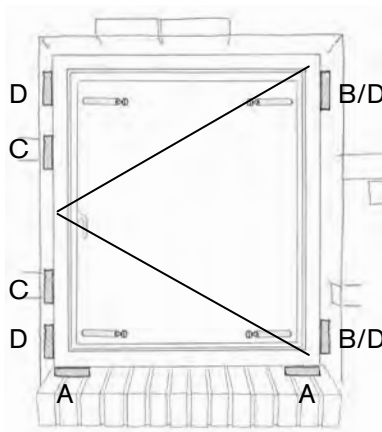

Sidehinged VELFAC 200

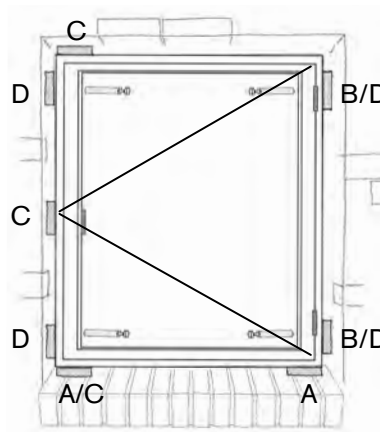

Sidehinged VELFAC Ribbo

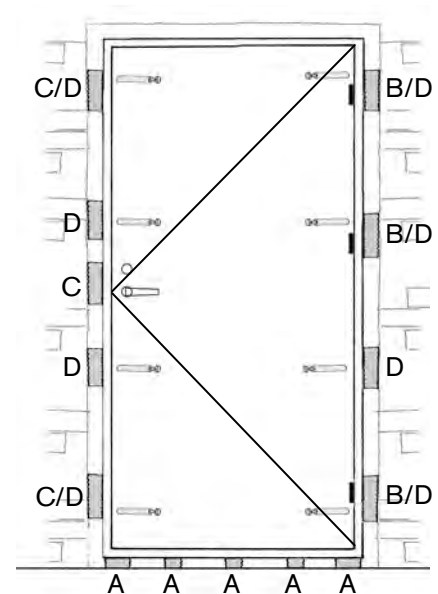

VELFAC entrance, patio and sliding casement doors

### Final fixing.

Once packed as per above, VELFAC product can be directly fixed into the substrate through the timber mainframe sections. Refer to pages 8-10 for the required process. Through frame fixings must be of a suitable size and specification and must be packed accordingly.

Where build sequence has windows installed before the outer facade, to maintain product warranty and aid functionality all packing processes identified above must be undertaken once the facade has been formed.

Where VELFAC design drawings have been completed, these details would take precedent over the process described above.

# Horizontal and Vertical Coupling Guidance & Principles, 1/5

## Coupling VELFAC 200 to VELFAC 200

All coupling joints must be a minimum of 8mm but can vary dependent on the buildup / configuration of the elements, specifically

- Sidehung windows / Casement doors that are hinged next to each other require a coupling joint of 15mm to enable functionality. Where a T-piece is being used at the coupling location this should be the 16mm variant.
- Sidehung Windows / Casement doors that are hinged towards a reversible element require a coupling joint of 10mm to enable functionality.
- Nominal screw size: 6mm x 75mm long bright zinc plated countersunk woodscrew.

The VELFAC 200 DGU system is coupled in the same way as VELFAC 200 ENERGY. Please find coupling details in our product database.

Typical examples shown below.

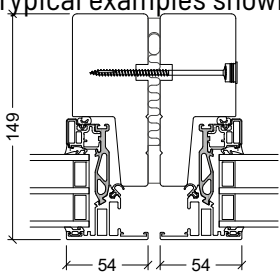

Horizontal coupling (side-by-side)

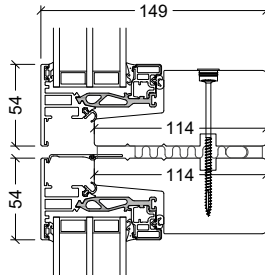

Vertical coupling (stacked)

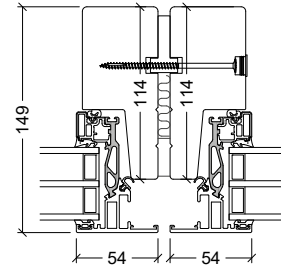

T Section Coupling

Sealing of the joints externally is generally completed using Illbruck TP600 Impregnated foam tape sized correctly to suit the joint, the tape must have a minimum depth of 20mm. Internally the joint unless a T section has been applied will be a VELFAC approved silicone, ie Illbruck FS 125. The void in between the external and internal seal must be filled with either loose fill mineral wool or PU Foam, if the latter is used care must be taken to prevent excess spillage.

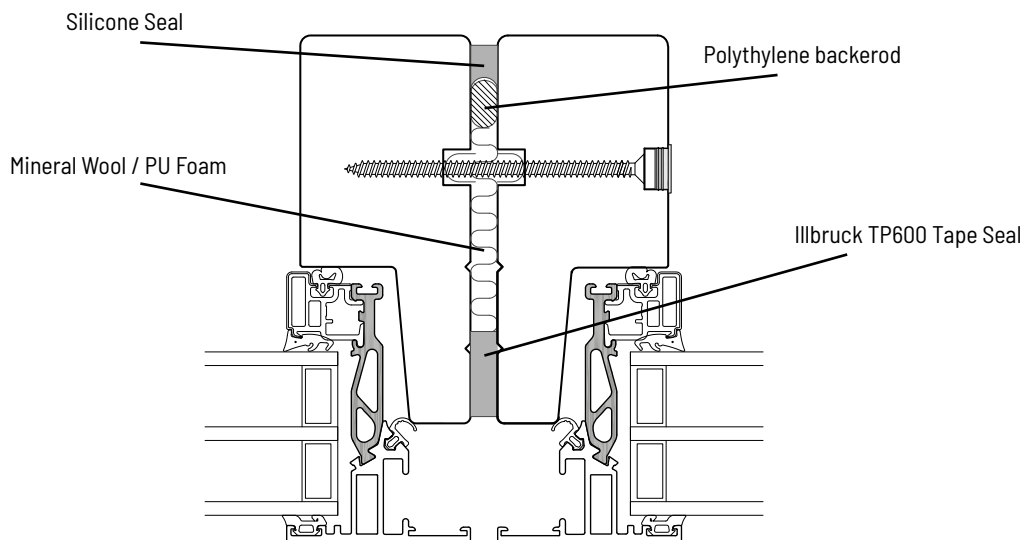



## Horizontal and Vertical Coupling Guidance & Principles, 2/5

### VELFAC 200 Stacked elements

Where elements are vertically stacked and coupled a stacker flashing profile must be installed at every 3metre joint. This is required to assist in dispersing water from large surface areas and the coupling joint size must increase to 20mm.

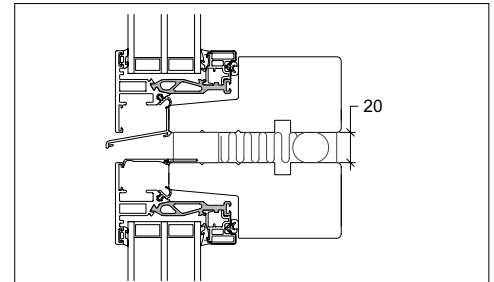

### VELFAC 200 Corner and Facet

Corner and facet posts are supplied loose and must be formed / built on site. Please observe:

- All posts are rebated to accept a Illbruck TP600 tape seal. This must be applied at point of install to prevent water migration at these locations.
- Alternatively a silicone seal can be applied using an approved product ie Illbruck FS 125.
- Nominal screw size: 6mm x 75mm long bright zinc plated countersunk woodscrew.

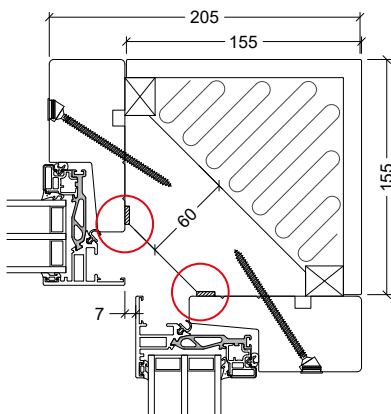

90° internal cornerpost detail.

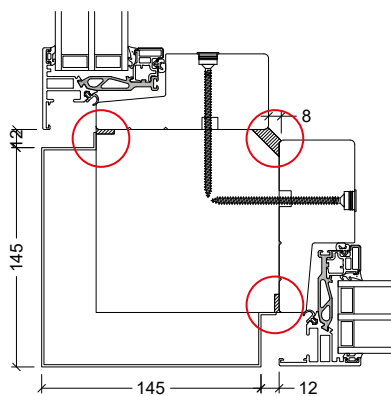

90° external cornerpost detail.

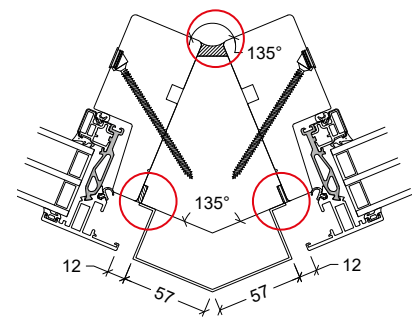

135° external cornerpost detail.

 Apply Illbruck FS 125 silicone seal during installation.

You can see more examples of couplings in our Product database

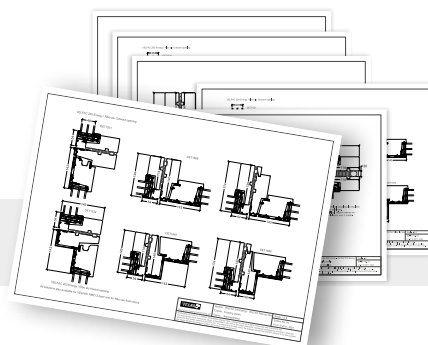

## Horizontal and Vertical Coupling Guidance & Principles, 3/5

### Coupling VELFAC 200 to VELFAC Ribo & VELFAC Aluminium doors

- Nominal screw size: 6mm x 75mm long bright zinc plated countersunk woodscrew.
- However for aluminium door only 6mm x 50mm.

The VELFAC 200 DGU system is coupled in the same way as VELFAC 200 ENERGY. Please find coupling details in our product database.

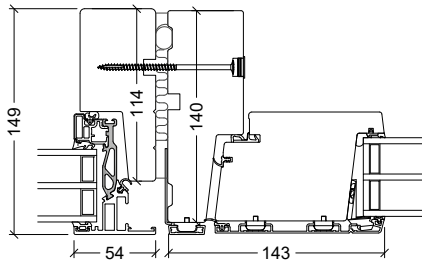

with VELFAC Ribo outward opening door (cover profile\*)

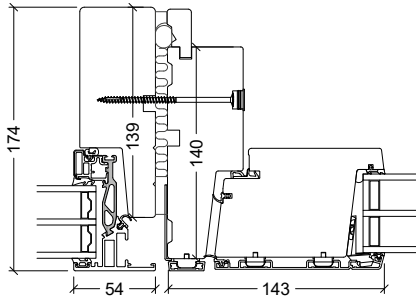

with VELFAC Ribo outward opening door (cover profile\*).  
Depth packer is factory fitted. Otherwise please contact VELFAC

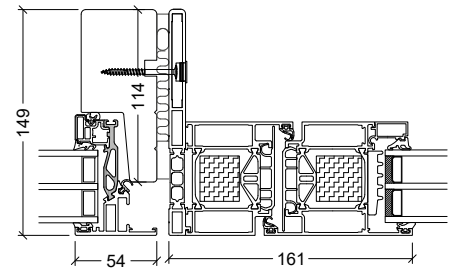

with VELFAC Aluminium door, outward and inward opening (5mm x 50mm screw)

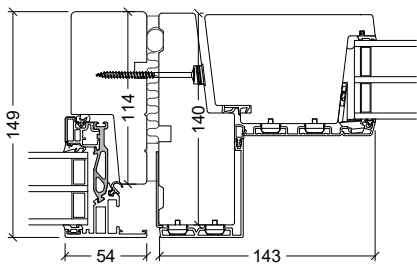

with VELFAC Ribo inward opening door (cover profile\*)

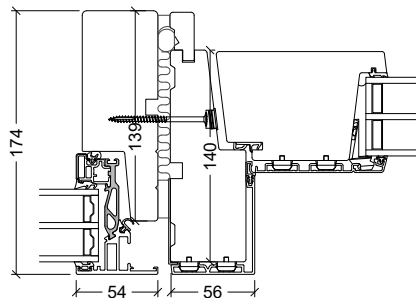

with VELFAC Ribo inward opening door (cover profile\*).  
Depth packer is factory fitted. Otherwise please contact VELFAC.

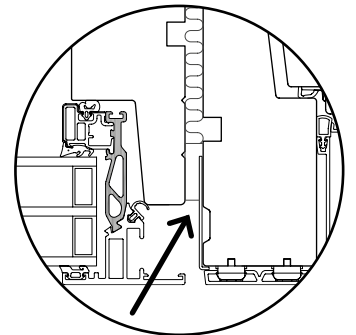

\*The cover profile (+1.5mm) protects VELFAC Ribo against rot when coupled with VELFAC 200. The profile must run down both jambs and across any head interface. The cover profile is factory-fitted. If not please contact VELFAC.

### Coupling VELFAC 200 to VELFAC In

- Formed on site at point of installation.
- Coupling can only be completed entirely horizontally or vertically, not both.
- VELFAC In cannot be coupled to a VELFAC 200 fully reversible window.
- Nominal screw size: 6mm x 60mm long bright zinc plated countersunk woodscrew.

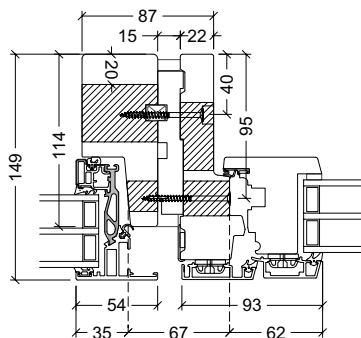

with VELFAC In (coupling profile, see illustration (1.-4.))

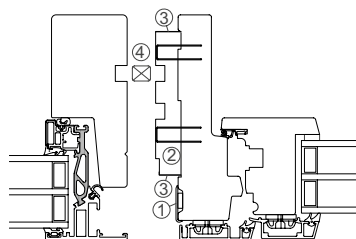

**Factory fitted:**  
1. Cover profile, 2. Coupling profile, 3. Bond breaker tape

**Supplied separately:**  
4. 150mm alignment profile

# Horizontal and Vertical Coupling Guidance & Principles, 4/5

## Coupling VELFAC Ribo to VELFAC Ribo

- Nominal screw size: 6mm x 75mm long bright zinc plated countersunk woodscrew.

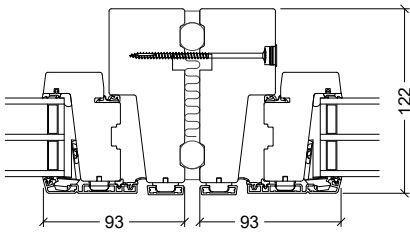

Horizontal coupling  
Window to window

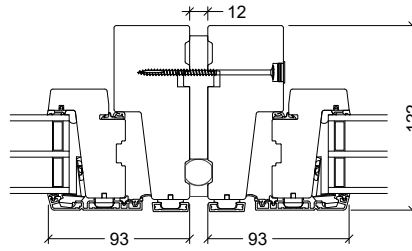

T Section coupling  
Window to window

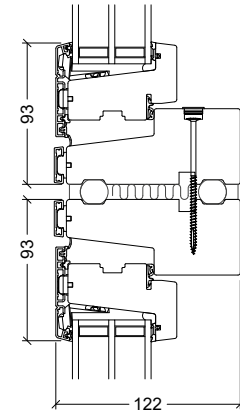

Vertical coupling  
Window to window

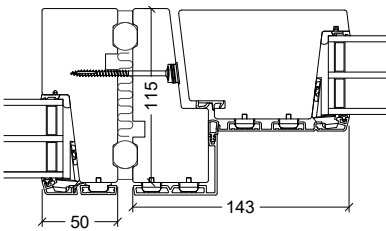

Horizontal coupling  
Window to inward opening door

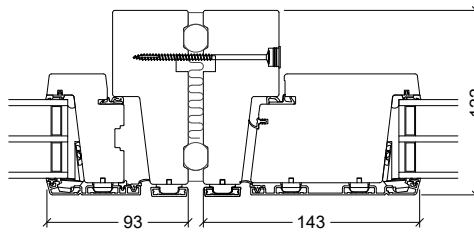

Vertical coupling  
Window to outward opening door

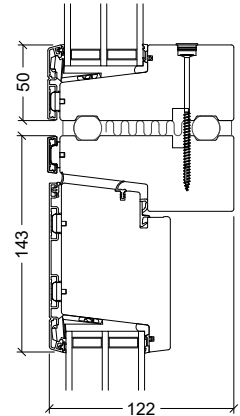

Vertical coupling  
Door with fixed top-light

## VELFAC Ribo Corner and Facet

- Corner and facet posts are supplied loose and must be formed / built on site.
- Silicone seal to be applied at highlighted locations to prevent water migration.
- Nominal screw size: 6mm x 75mm long bright zinc plated countersunk woodscrew.

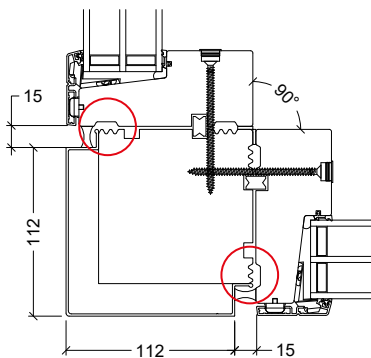

90° external cornerpost detail

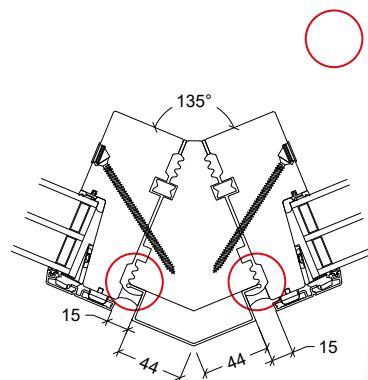

135° external cornerpost detail

 Apply Illbruck FS 125 silicone seal during installation.

You can see more examples of couplings in our Product database

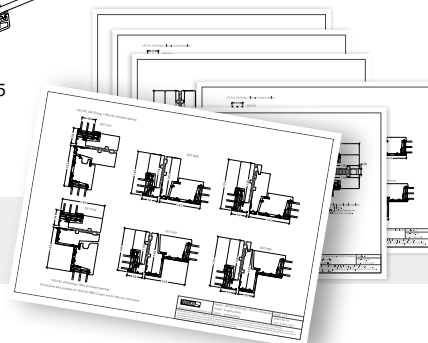

## Horizontal and Vertical Coupling Guidance & Principles, 5/5

### Coupling VELFAC Ribo to VELFAC Aluminium doors

Coupling joint range 10-12mm, elements must not be coupled without this joint space.

Nominal screw size: 6mm x 50mm long bright zinc plated countersunk wood-screw.

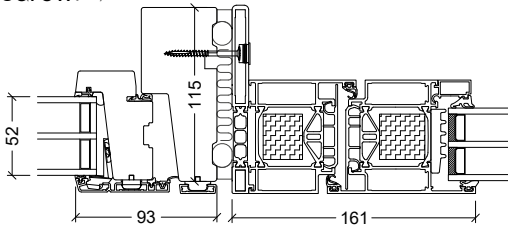

Horizontal coupling  
Window to outward or inward opening door

### Coupling VELFAC Ribo to VELFAC In

- Coupling joint required 12mm
- Coupling should be either entirely vertical or horizontal, not both.
- Nominal screw size: 6mm x 60mm long bright zinc plated countersunk woodscrew.

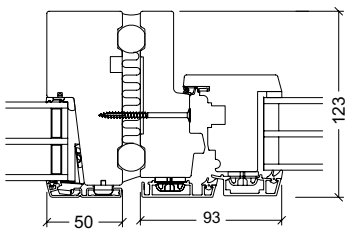

Horizontal coupling  
Window to window

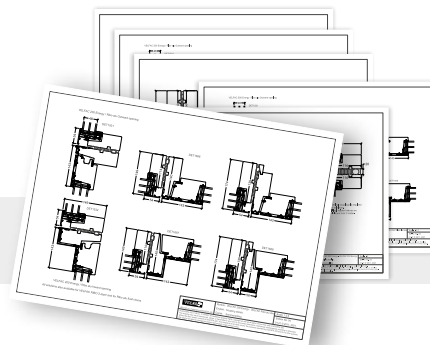

You can see more examples of couplings in our Product database

## Sealing Solutions - General Principles

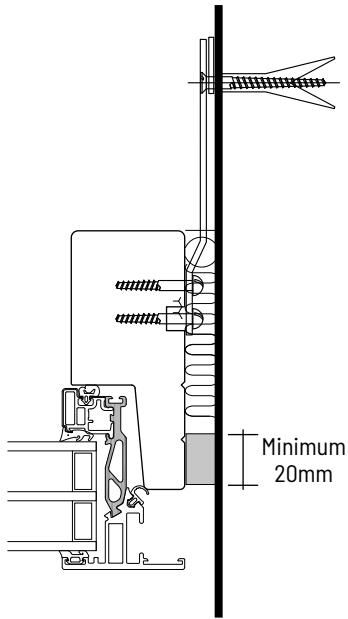

### Perimeter sealing

The nominal joint size to the perimeter of a VELFAC product is 12mm +/- 3mm. The common type of seal used is Illbruck TP600 Impregnated Foam Tape 20-8/15. Where joints exceed the maximum 15mm parameters of this tape variant the next incremental size should be used.

An approved wet seal application ie Illbruck FS 125 should be considered dependant upon the location of the installation ie its proximity to the coast, its altitude above seal level its exposure to adverse weather conditions.

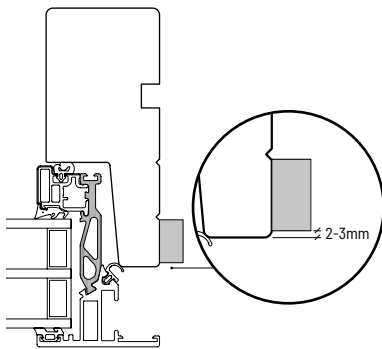

For VELFAC 200 the seal sits just inboard of the radiused timber nosing

### Sealing types

Seal for a VELFAC 200 product would be Illbruck TP600 impregnated foam tape sized to suit the joint with a minimum thickness of 20mm or Illbruck FS 125 Silicone for standard applications, Illbruck FA 880 for natural stone applications.

Priming may be required and guidance should be sought from the product manufacturer.

When using an Illbruck TP600 tape seal the face of the seal must sit approximately 2-3mm inboard of the timber mainframe nosing.

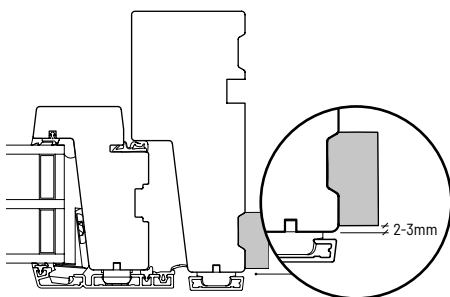

For VELFAC Ribo the seal sits just inboard the aluminium clad

Seal for a VELFAC Ribo product would be a Illbruck TP600 impregnated foam tape sized to suit the joint with a minimum thickness of 25mm or Illbruck FS 125 Silicone for standard applications, Illbruck FA 880 for natural stone applications.

Priming may be required and guidance should be sought from the product manufacturer (CPG).

When using an Illbruck TP600 tape seal the face of the seal must sit approximately 2-3mm inboard of the timber mainframe nosing.

## Sealant Application – Do’s and Don’ts

### Illbruck TP600 Impregnated Foam Seals Best Practice

- Illbruck TP600 must be minimum 20mm deep for VELFAC 200 & 25mm deep for VELFAC RIBO.
- Standard size used is 20, 25 / 8 / 15 for a 12mm joint.
- If maximum expansion parameters are exceeded on any part of the joint a larger tape must be used.
- Illbruck TP600 requires a solid substrate to seal against i.e. brick, block, render, cladding etc.
- Illbruck TP600 should not be used where random stone form the interface.
- Substrate should run parallel to the window element and be in good condition.
- Illbruck TP600 can be butt jointed.
- Illbruck TP600 should not be folded around corners.

### Wet Seal Application Best Practice

- Only use a VELFAC approved product.
- Always engage a competent applicator.

### Perimeter Joint Preparation Best Practice Guidance

The joint surfaces must be clean, dry and free from all contamination. In some instances, in order to gain / maintain a viable seal the use of a priming agent may be required.

**Joint Backing.** Where applicable, appropriate joint filler i.e., closed cell polyethylene foam (backerod) should be used to provide the correct joint depth and also to avoid three-way adhesion.

**Application.** All joint preparation, priming, and sealant application should be carried out in accordance with manufacturers recommendations.

**Joint Width / Depth Ratio.** To provide viability and longevity any perimeter joint seal size ratio should be based on 2:1 width versus depth with an absolute minimum depth being 6mm i.e.

- A 10mm wide joint should achieve a minimum 6mm depth
- A 15mm wide joint should achieve a minimum 7.5mm depth
- A 20mm wide joint should achieve a minimum 10mm depth

### Illbruck TP600 Sizes approved by VELFAC

20 / 5 / 10  
 20 / 7 / 12  
 20 / 8 / 15  
 20 / 10 / 18  
 25 / 8 / 15  
 25 / 13 / 24  
 35 / 17 / 32  
 40 / 24 / 40

### Wet Seal Applications approved by VELFAC

Illbruck FS 125 Silicone  
 Illbruck FA 880 Silicone  
 Adsheed Ratcliffe ARBO 1090

### PU Foam Applications approved by VELFAC

Illbruck FM 330  
 Illbruck Nullifire FF 197

### Nylon packers

approved by VELFAC  
 to be bought from Finish Architectural Ltd

### Bonding / Adhesive Applications approved by VELFAC

Illbruck FP 350

# VELFAC 200 Windows, Installation Best Practice

## Stage 1

- Remove all packaging from the window perimeter and dependent on what fixing method is being used prepare the window in line with information detailed on pages 8-9.
- Apply the Illbruck TP600 seal across the head of the window only ensuring it is the correct length and is in the correct position. Refer to images to the left.
- Lift the window into the opening adopting a safe and robust methodology.
- Pack the window up at all vertical load points using a bridging plate, then finite pack using these as a base to gain the required perimeter seal joint size.
- Check for level and amend the packing if required.
- At cill level position the window central within the opening and pack to prevent movement.

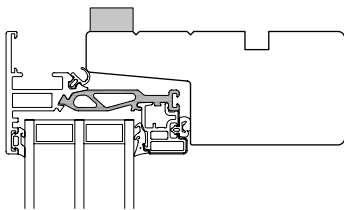

For VELFAC 200 the seal sits just inboard of the radiused timber nosing and should maintain this position to the full perimeter of the window element.

## Stage 2

- Position the window to the required set back at the cill ensuring that the max and minimum set back dimensions are not exceeded.
- Plumb the window up and again pack side to side close to the head to temporary maintain position.
- Apply fixings at jamb locations pack as required, ensure when lug fixing that sufficient packing is used to prevent distortion of the lug, too much or too little packing may affect the functionality of the window.
- Check for plumb and level again and check any opening element to ensure smooth operation.
- Apply the Illbruck TP600 seal to the cill and jamb location and leave to expand.

## Stage 3

- Install the cill pressing and seal with silicone at structure abutment, ensuring that the cill is packed sufficiently to gain a fall and aid water dispersal.
- Internally apply an approved PU Foam Illbruck FM 330 to the perimeter of the window.

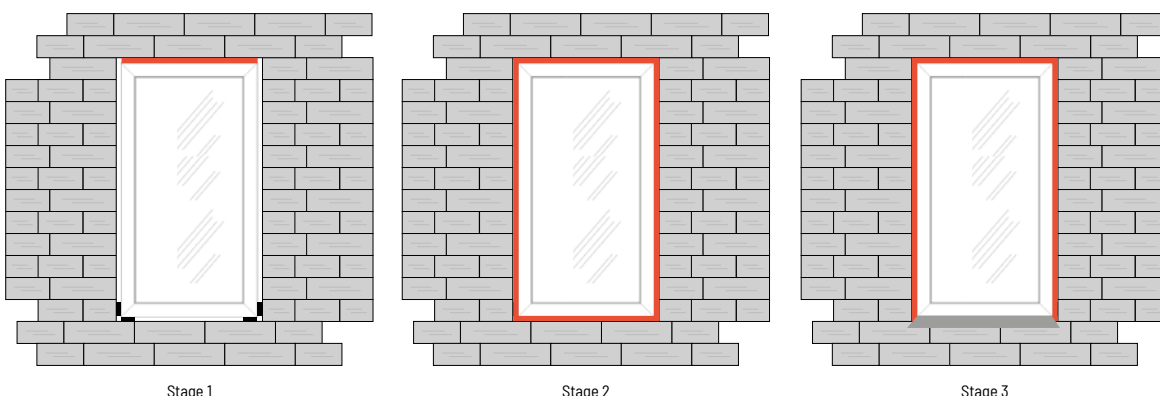

Stage 1

Stage 2

Stage 3

# VELFAC 200 Windows + Casement Door, Installation Tips, 1/2



## Sidehung windows

Where hinge positions are against a facade an additional tolerance allowance is required to avoid clashing of hardware and structure when in the open format. The hinge takes up approx. + 7mm when the window is open, therefore in these instances a minimum tolerance of 12mm is required.

Where hinges are coupled side by side the coupling joint size at this point should be minimum 15mm to avoid hardware clashing when in the open format. Where a T-piece is being used at the coupling location this should be the 16mm variant.



## Tophung reversible windows

NOTE against wall: Where hardware sits adjacent to the structure approximately 4mm will be exposed and visible.

NOTE couplings: When coupling reversible elements together the coupling joint formed must be a minimum 10mm to avoid hardware clashing.

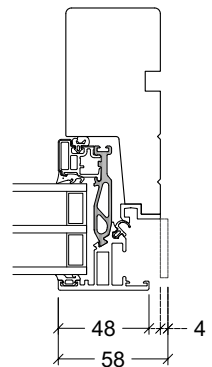

## Casement door

NOTE against wall: Where hardware sits adjacent to the structure tolerance allowance should be considered as the hardware will clash if insufficient allowance is made. The hinges take up approx. + 7mm of space when in the open format, therefore in these instances a minimum tolerance of 12mm is required.

NOTE couplings: Where hinges are coupled side by side the coupling joint size at this point should be minimum 15mm to avoid hardware clashing when in the open format.

The 2-leaf casement door is available in three different threshold heights and types.

The threshold in 2-leaf doors should always be fixed below the French casement mullion. Please see principle sketches for fixing the three thresholds on the next page.

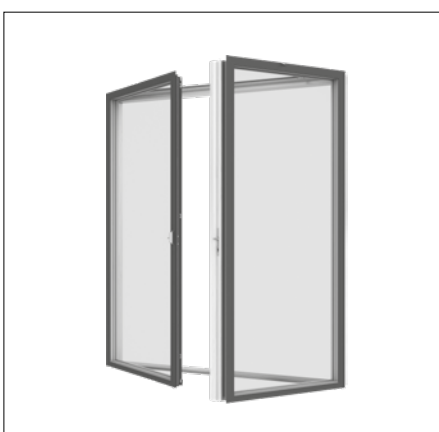



VELFAC 200 Windows + Casement Door, Installation Tips, 2/2

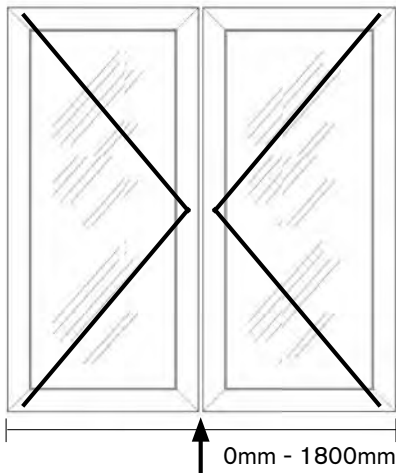

The threshold in 2-leaf doors should always be fixed below the French casement mullion. Please see principle sketches per threshold below.

NB: There should be further intermittent fixings across the length of the threshold with centers no greater than 200mm, please refer to page 14.

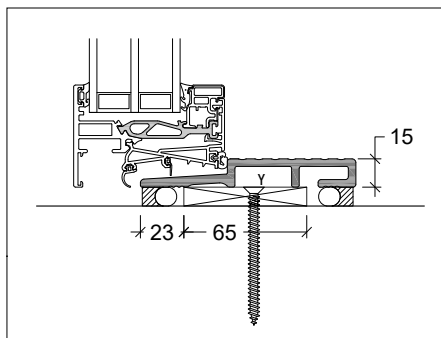

**15mm HELO threshold.** Fix a continuous support block to the structure then bond the threshold to the packer using a Illbruck SP350 (Y).

Ensure the threshold creates a bond against the sealant to avoid deflection of the threshold.

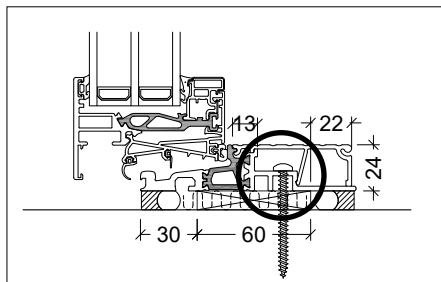

**24mm alu/PA threshold.** Fixing must be done vertically into the structure beneath the French casement mullion. Do not fix through the aluminium tread-plate, but install it afterwards.

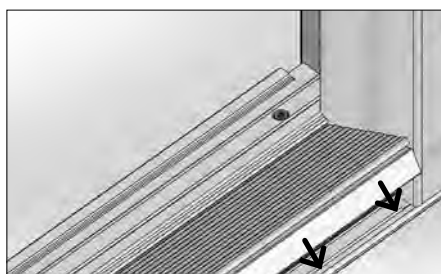

Place the aluminium tread-plate into the top of the threshold, pivot down and press it into place. To avoid post install damage this component can be installed closer to project completion.

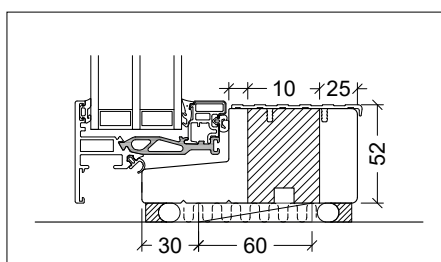

**52mm threshold with aluminium treadplate.** As standard fixing, under the French casement mullion.

VELFAC 200 Sliding Casement Door, 24mm Threshold, Installation Best Practice, 1/4

**General Installation Principles**

Installation shall always be performed from the outside, or at least with access from the outside, as packing for dead load, adjustment and coupling of sashes cannot be carried out from the inside only.

When installing this product, the threshold must be fully supported across its length and width. Example drawings can be found on the VELFAC website.

- The building structure forming the support must be level with degrees of tolerance restricted to + / - 1mm from end to end.
- The product is delivered with a factory fitted resin packers which are fitted to the underside of the threshold in the factory at 200mm centres but can move during transit and or distribution. The purpose of these is to support the front edge of the threshold section when the sliding unit is in the open mode.
- Resin packers should be positioned under each jamb and any intermittent mullion with the balance then positioned at centers no greater than 200mm.

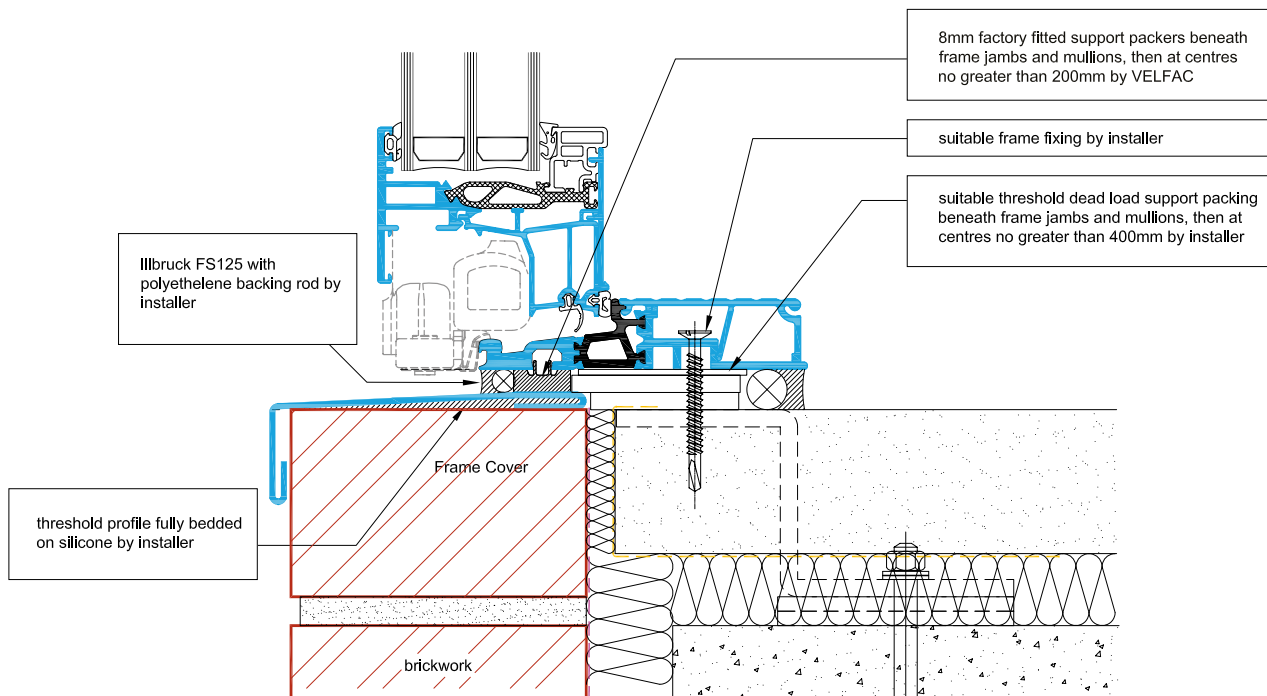

Indicative fixing arrangement for VELFAC 200 ENERGY sliding casement doors with 24mm Threshold

**Mandatory packing points below threshold**

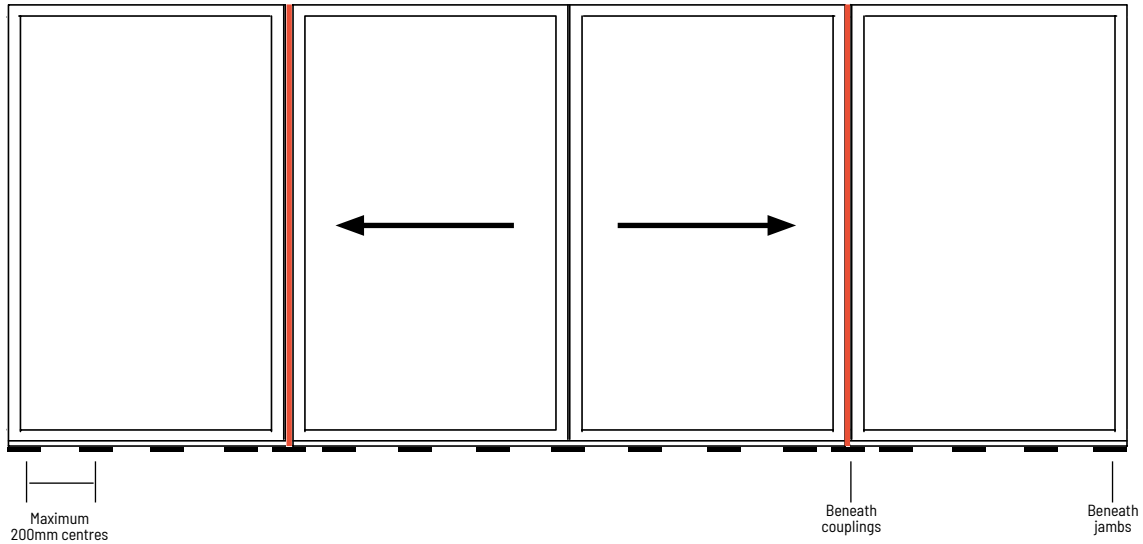

- To the inside of the threshold further packing shims / plates should be positioned directly under each jamb and intermittent mullion.
- Fixings should be applied as per the Construction Issue Detail if applicable or best practice guidance 100-150mm from either end then at centers no greater than 400mm and packed accordingly.
- Fixings to the head and jamb should be completed as per the Construction Issue Detail if applicable or best practice guidance 100mm-150mm from each corner with maximum centers thereafter no greater than 600mm. If fitted with Enhanced Security, please see details on the next page.
- The sliding unit of this product is very sensitive to tolerance therefore it is critical that when installing this product, the above points are adhered to if functionality is to be maintained.
- Where the fixing substrate falls outside the tolerances indicated or is deemed insufficient this must be brought to the attention of the customer and remedial actions must be taken prior to installation commencement.
- Upon completion the element must be checked for plumb level and square with any adjustments being undertaken immediately. Externally sash alignment should be checked with the gap between sashes being 8mm (+ / - 1mm).

**Mandatory fixing centres**

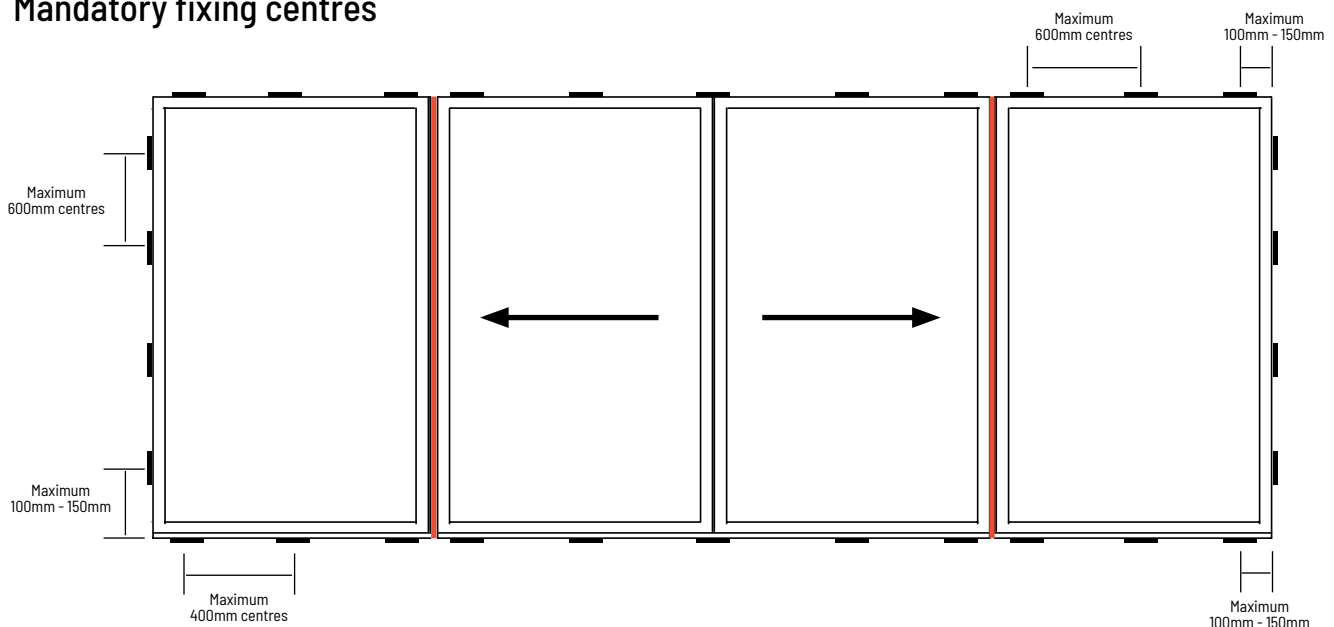

**1-leaf with Enhanced Security**

- When installing a single leaf slider where enhanced security locks have been applied at point of manufacture, fixing brackets at jamb locations must be positioned to avoid bracket screws damaging the lock casements.

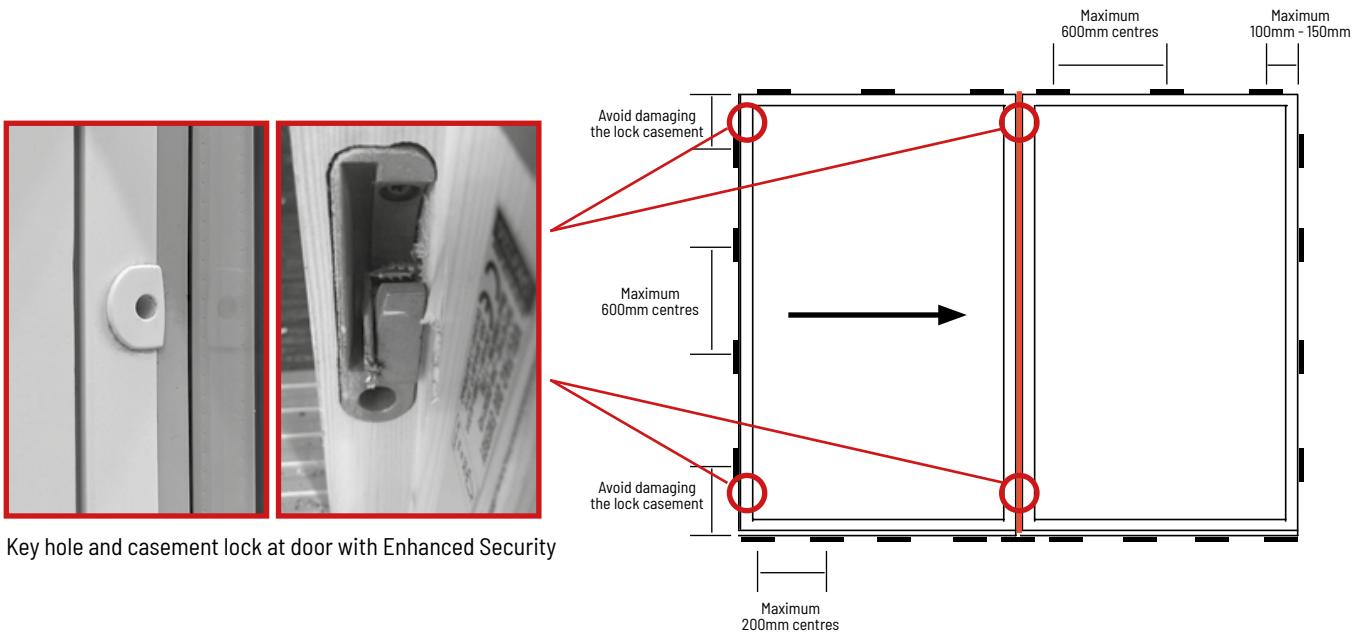

Key hole and casement lock at door with Enhanced Security

**Watch video**

Prior to installation we recommend to see the video on our YouTube channel: "Installation of VELFAC 200 ENERGY sliding casement door with 24mm threshold".



[See video](#)

**Packing and fixing at threshold locations**

To allow fixing through the sliding door threshold the aluminium tread-plate is supplied only partially installed and must be removed prior to fixing.

When all fixings (Z) have been applied and the sliding units have been checked for functionality, the tread-plate should be positioned and clipped in place.

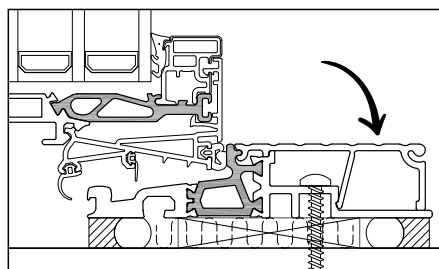
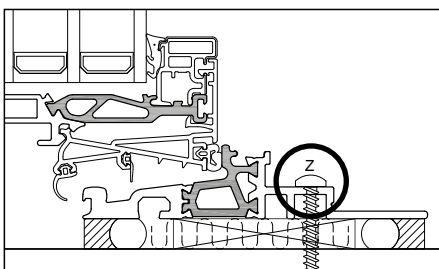

## VELFAC 200 Sliding Casement Door, 24mm Threshold, Installation Best Practice, 4/4

In 2-leaf sliding doors, however, the tread-plate is installed from the factory and should be removed prior to fixing of the unit. Carefully insert a wooden wedge or flat bladed tool into the groove on the back of the tread plate and gently lever downwards un-clipping the section at intermittent points until completely loose.

Carefully remove the tread-plate and set it aside.

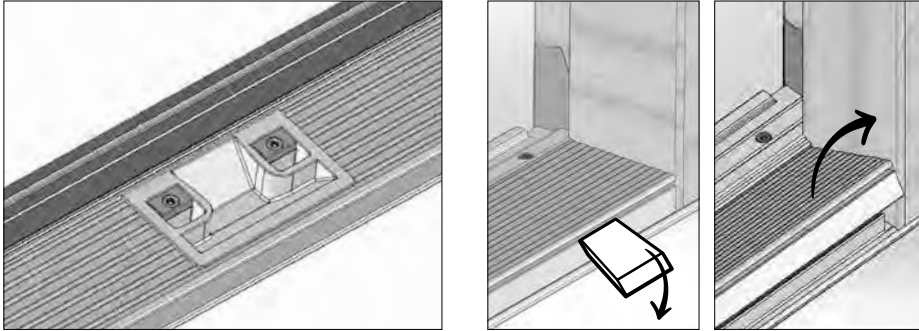

### Coupling principles for 2-leaf Sliding Casement Doors

For the 2-leaf variant there will be a necessity to build / couple the units together on site. For this purpose, there are two options these are referred to as the:

- Commercial Option
- Domestic Option
- At coupled joints the commercial option consists of a minimum 8mm joint (up to a maximum 16mm) being formed between the units this is done by using proprietary packers with the units then being screwed together at 100-150mm from the top and bottom transom rail then at intermediate centres no greater than 600mm.
- Nominal screw size: 5mm x 60mm long bright zinc plated countersunk woodscrew.
- From an internal perspective the joint is then silicone sealed using the VELFAC approved Illbruck FS 125 while the external joint is sealed using a Illbruck TP600 impregnated foam. The cavity between the seals should be filled using loose fill mineral wool or similar.
- The Domestic Option see a timber T profile being introduced to replace the internal silicone seal, the coupled joint size parameters remain the same ie minimum 8mm maximum 12mm and there are T sections to accommodate this range. The requirement for the external seal and mineral wool fill remains the same.

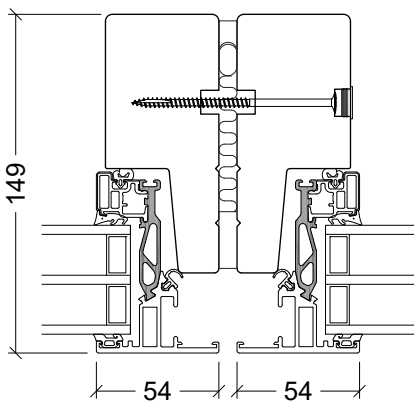

Commercial Option

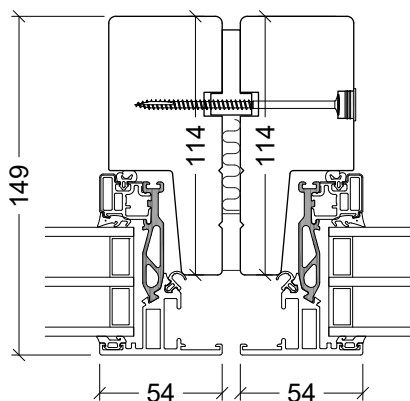

Domestic Option

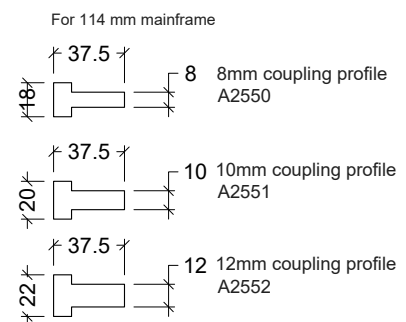

T Section Coupling

A. B. C.

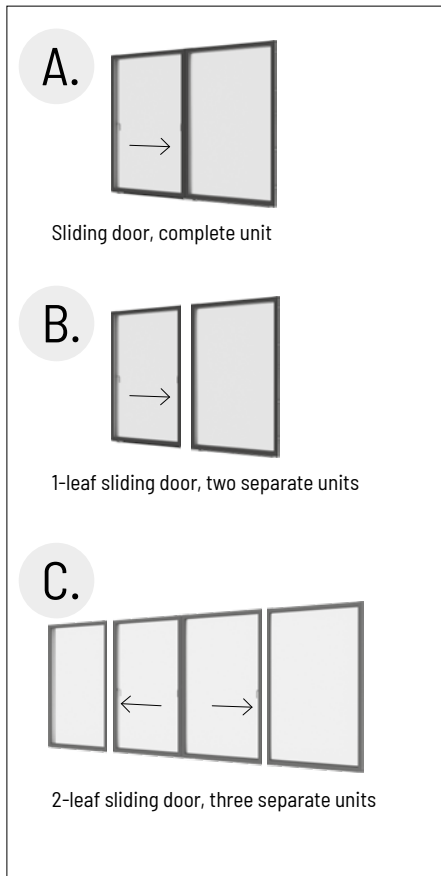

**Delivery to site.** There are three configuration options for a sliding unit:

- A. 1-leaf sliding door as a complete unit
- B. 1-leaf sliding door as two separate units or
- C. 2-leaf sliding door as three separate units.

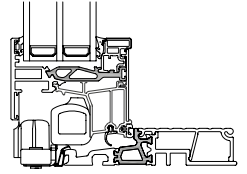

**Packing and positioning in structural openings,** which is described on the following page (page 31), applies to all three types (A+B+C).

Guidance, which is **specifically applicable to one of the configurations** can be found on the following pages:

- 1-leaf sliding door as a complete unit (A), page 32.
- 1-leaf sliding door as two separate units (B), pages 33-38.
- 2-leaf sliding door as three separate units (C), pages 39-46.

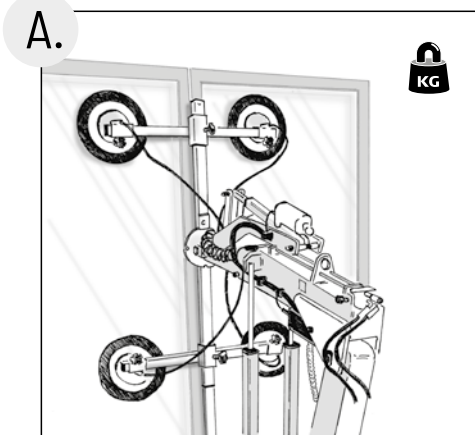

**Starting tips:**

**1. For configurations A, B and C:** For all configurations to allow a successful installation clear unhindered access is required both externally and internally, as packing for dead load, adjustment and coupling of sashes cannot be carried out from the inside only.

**2. For configuration A:** If the sliding door is delivered as a complete unit, it can be positioned into the fully formed structural opening by means of the site-specific lifting/handling method. **NOTE:** Always lift both sashes.

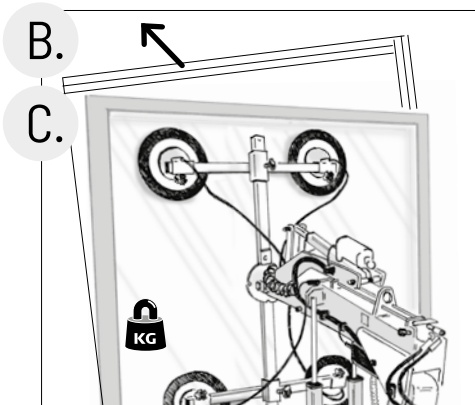

**3. For configurations B and C:** If the sliding door is delivered as 2 or 3 units, each unit must be desashed, before the frames are placed and coupled together in the fully formed structural opening. This makes it easier to connect the carriages and top arms.

A. B. C.

**4. For configurations A, B and C:**

Accurately installed frames will require fewer adjustments!

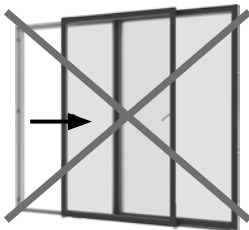
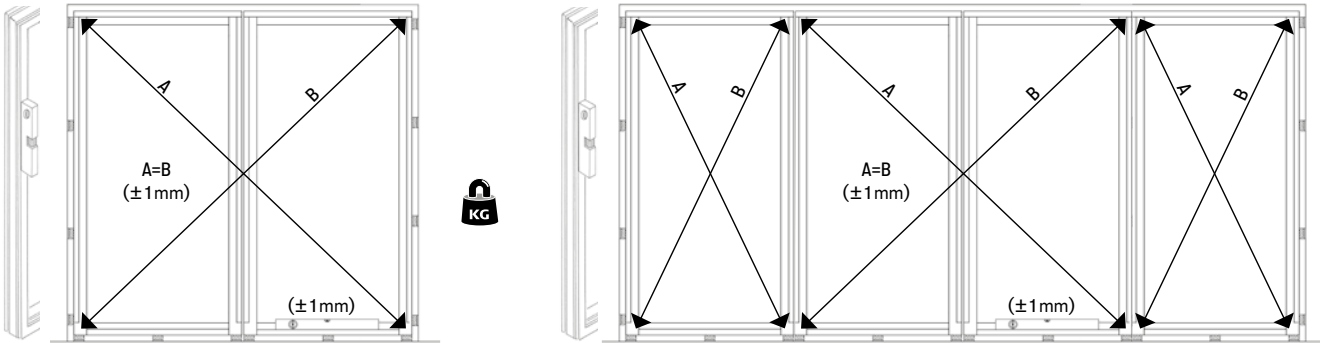

**5. WARNING!** Never try to operate the sliding sash until the unit is suitably supported and stable as this will damage the frame.

**6. Transoms.** Any transoms in 2-leaf units must be installed as self-supporting structures. Insert, e.g. steel lintels. Loads placed on the sliding door by transoms will inhibit its ability to work optimally.

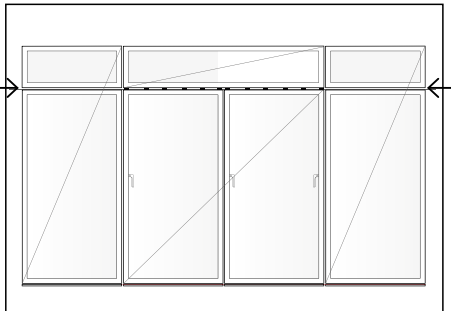

**7. Check functionality.** The sliding unit should operate smoothly with minimum effort required to open and close. Adjust if necessary please see the VELFAC 200 Desashing & Adjustment Guide.



The following pages include special instructions for 1-leaf sliding doors delivered as complete units (page 32), as separate units (pages 33-38) and 2-leaf (pages 39-46).

VELFAC 200 Sliding Casement Door, 24mm Threshold, 1-leaf, complete unit, 3/18

A.

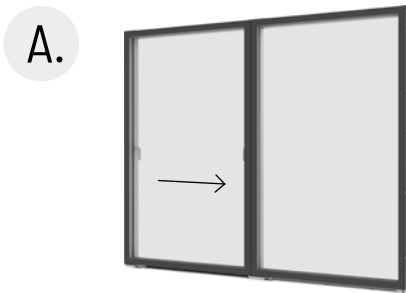

1-leaf sliding door, complete unit

The 1-leaf unit can be installed without the need to remove the aluminium sashes from their mountings as adjustments have been undertaken during the manufacturing process.

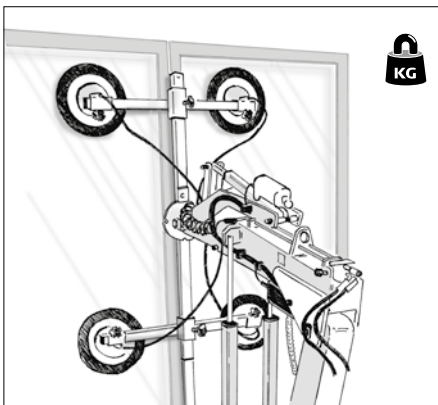

Position the sliding door into the fully formed structural opening with suitable lifting gear,

NOTE: If using mechanical lifting aids apply to both sashes.

In the event that the removal of sashes cannot be avoided, the fixed sash should be removed (see pages 33-34). Possibly also the opening sash (see pages 34-36).

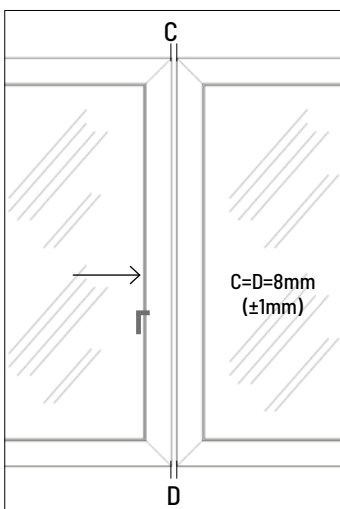

**Tolerances.** Close the sliding casement door and measure the distance between the sashes at the points C and D. The distance between the sashes must be:  $C \geq 8\text{mm}$  and  $D \geq 8\text{mm}$ .

Max 1mm difference between C and D measurements is allowed. If the result is not within the tolerance limit, adjust the installation of the frame. Otherwise the operation of the sliding door will work poorly.



**Check functionality.** The sliding unit should operate smoothly with minimum effort required to open and close.

The sliding door is now ready for use.



VELFAC 200 Sliding Casement Door, 24mm Threshold, 1-leaf, separate units, 4/18

B.

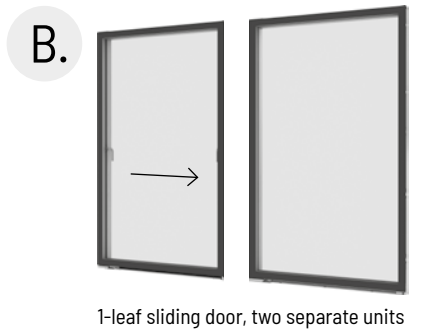

The 1-leaf sliding door delivered as two separate units should be installed removing the aluminium sashes first:

- Desash the fixed unit as per below description.
- Desash the opening unit as per below description.
- Position the timber main frames into the fully formed structural opening and couple them together.
- Using suitable lifting gear resash first the opening unit, then the fixed unit assuring correct position of guide rails and carriages.

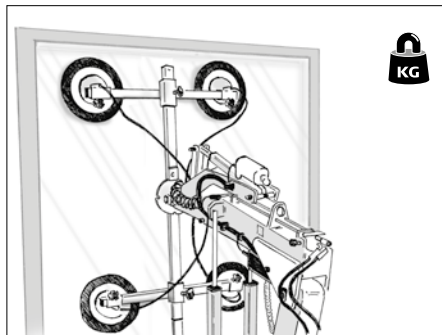

**How to desash the fixed unit.**

Secure the sash of the fixed unit with an appropriate lifting gear.



[See video 7:56](#)



Remove the internal cover cap in the top frame using the VELFAC Allen key provided to rotate the tumbler fixing through 90°.

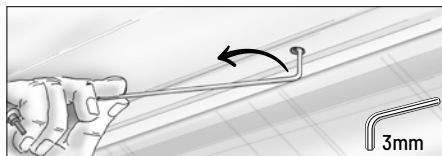

VELFAC Allan key, item no. 62.1167.

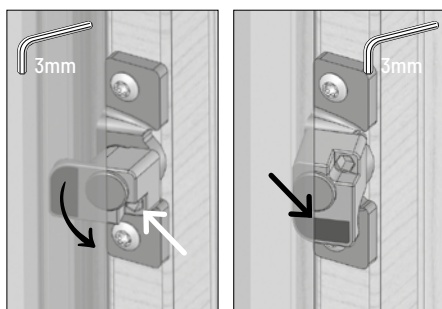

Apply the same process to the tumbler fixings located to the frame perimeter.

NB. The illustration of the tumbler fixings shows them on the right side of an unit seen from the outside. On the left side, they are fitted upside down, so the latch must be turned upwards (anticlockwise).

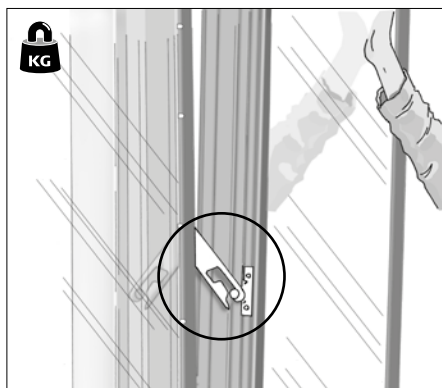

Tilt the frame out at the top. Use the safety catches to hold it at a 25-30° angle.

Ensuring at all times that the sash is safely retained, push the sash inwards releasing the pressure on the safety catches. Then release the safety catch on both sides of the sash by pushing it upwards.

VELFAC 200 Sliding Casement Door, 24mm Threshold, 1-leaf, separate units, 5/18

B.

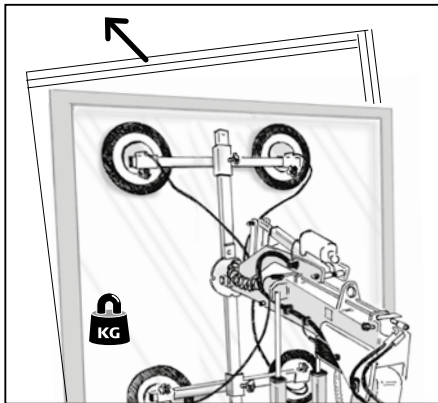

To complete the desashing process gently lift the sash and ...

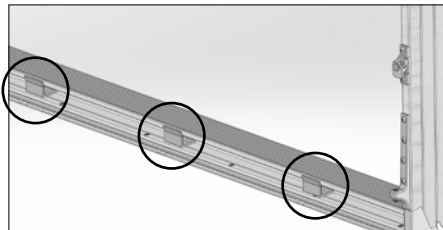

... remove it from the brackets on the threshold.



Store the sash in an upright position leaning on the aluminium sash, packed off of finished floor. Prevent any weight being applied to the plastic profiles that form part of the sash.

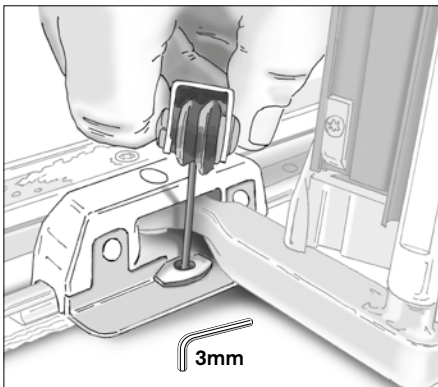

**How to desash the opening unit.**

Open the handles of the running sash. Pull the sash slightly outwards and slide it to the side so that the sliding door is slightly open.



[See video 9:08](#)

Using a 3mm hex key remove the safety catch in the running track.

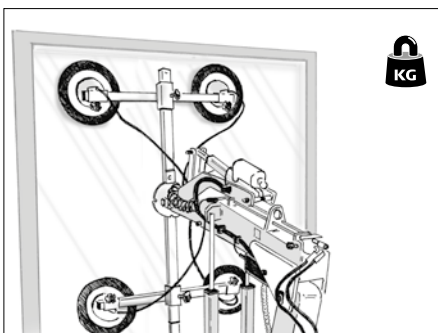

Secure the sash of the opening unit with an appropriate lifting gear.

VELFAC 200 Sliding Casement Door, 24mm Threshold, 1-leaf, separate units, 6/18

B.

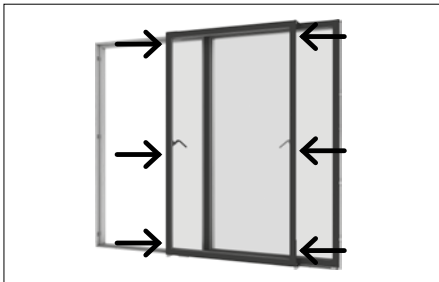

Now free the top slide arms. There are 3 grub screws in the guide rod in both ends of the sash. These secure the top slide arms.

To release the slide arms complete the steps below to both sides of the unit using a 3mm hex key (no. 1-6):

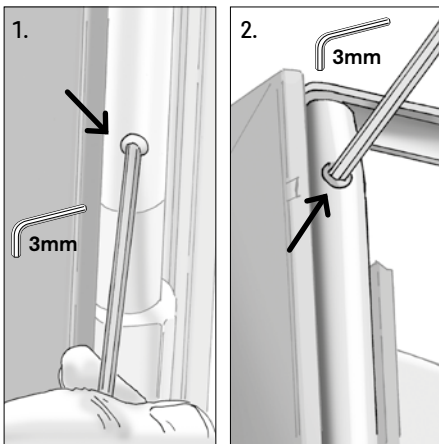

1. To temporary secure the wheeled truck, tighten the middle screw so it is level with the guide rod.

2. Loosen but do not remove the screw located at the top.

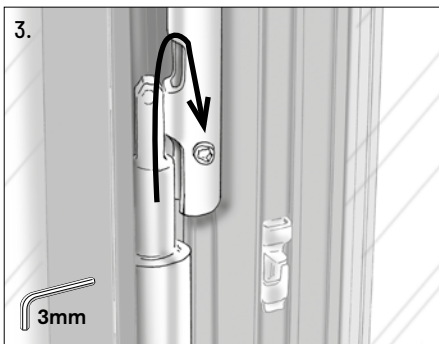

3. Loosen but do not remove the screw located at the bottom, this will allow the guide rod to be lifted out and repositioned to the side.

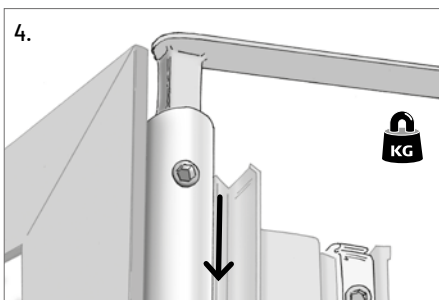

4. Lower the guide rod to release the top slide arm. The frame and sash of the opening unit have now been separated and the frame is ready to be installed (NOTE: section 5-6).

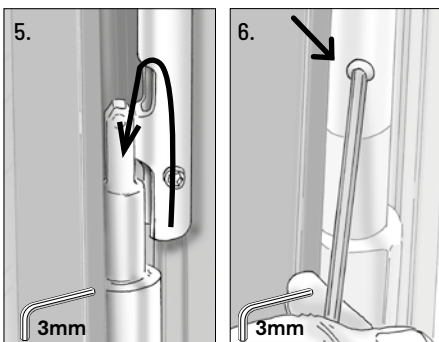

5. To ensure the tailstock screw cannot pass through the collar, lift the guide rod at both ends of the primary sash and re-tighten the tailstock screws at both top and bottom.

6. Finally, loosen the tailstock screw in the middle.

VELFAC 200 Sliding Casement Door, 24mm Threshold, 1-leaf, separate units, 7/18

B.

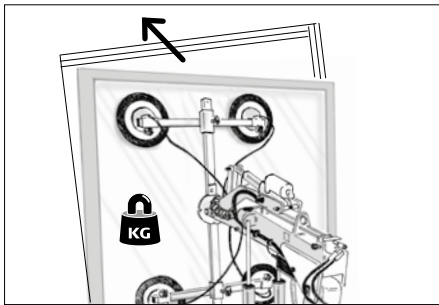

To complete the desashing process gently lift the sash and remove it from the threshold.

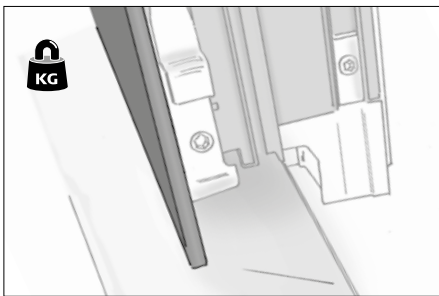

Store the sash in an upright position leaning on the aluminium sash, packed off of finished floor. Prevent any weight being applied to the plastic profiles that form part of the sash.

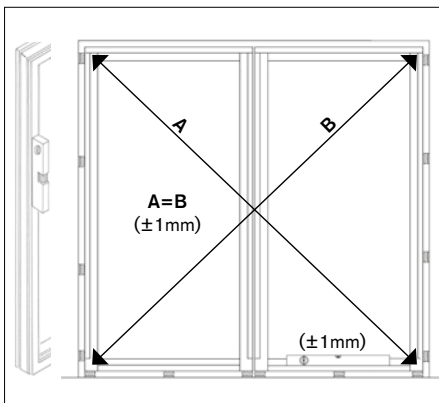

**Installation.** Place the frames in the fully formed structural opening and couple them together. This makes it easier to connect the carriages and top arms.

The frames must be assembled according to the same principles that apply to the fixing of jambs.

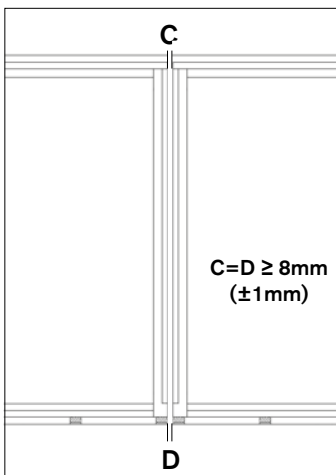

**Tolerances.** Running tracks must be level. Therefore, the spacing between the opening and fixed frame in points C and D must be precisely 8mm with max. 1mm difference between measurement C and D.

The following must be checked before final fixing:

- that the frames are positioned in a completely straight line
- that the frames are plumb and level
- that the diagonal measurements are complied within tolerances
- that the running tracks are level

VELFAC 200 Sliding Casement Door, 24mm Threshold, 1-leaf, separate units, 8/18

B.

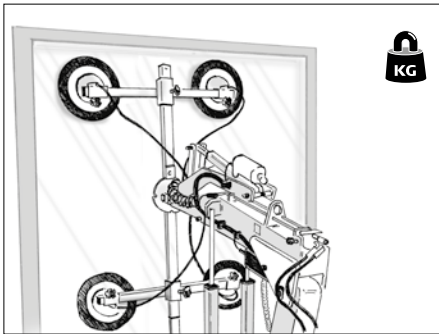

**How to resash the opening unit.**

Now lift the opening glazed sash and reinstate following the below guidance.



Carefully place the sash next to the frame so that it rests on the bracket arms of the carriage.



Lift the frame into place on the threshold, with one carriage positioned either side of the mullion.



Check that both carriages are positioned correctly on the running track.

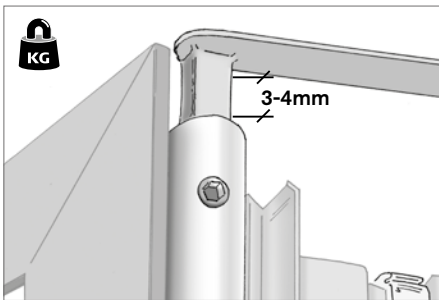

Follow this by reengaging the top slider arm in the guide rod at both ends by following sections 1-6 (see page 35).

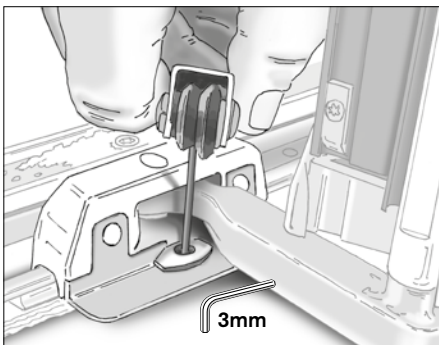

Finish by reinstating the safety catch in the running track.

VELFAC 200 Sliding Casement Door, 24mm Threshold, 1-leaf, separate units, 9/18

B.

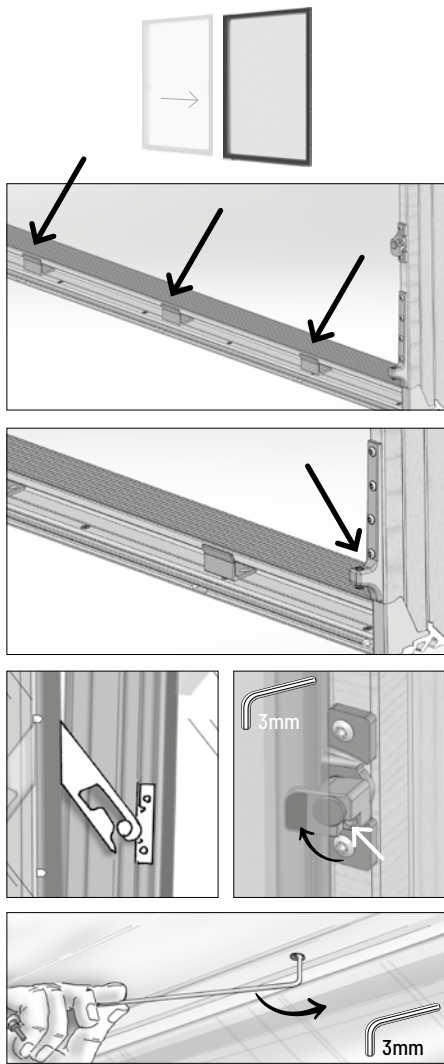

**How to resash the fixed unit.**

Use suitable lifting gear and position the fixed sash at the bottom:

- Gently lift the sash over the running track and lower it down carefully.
- The retainer brackets in the threshold should engage with the holes in the bottom of the sash..
- The sash should rest on the support arms at the bottom of the frame on both sides.
- Follow this by reinstating the safety catches on both sides so the sash cannot fall out.
- Press frame and sash together and turn the tumbler fixings located at the frame perimeter.

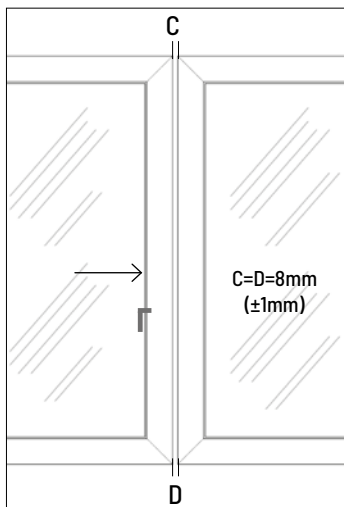

**Check that the sashes are level before final fixing.** Close the sliding casement door and measure the distance between the sashes at the points C and D. The distance between the sashes must be:  $C \geq 8\text{mm}$  and  $D \geq 8\text{mm}$ .

Max 1mm difference between C and D measurements is allowed. Adjust if required and check movement. Failing to adjust may affect the functionality of the door.



**Check functionality.** The sliding unit should operate smoothly with minimum effort required to open and close.

The sliding door is now ready for use.

VELFAC 200 Sliding Casement Door, 24mm Threshold, 2-leaf, separate units, 10/18

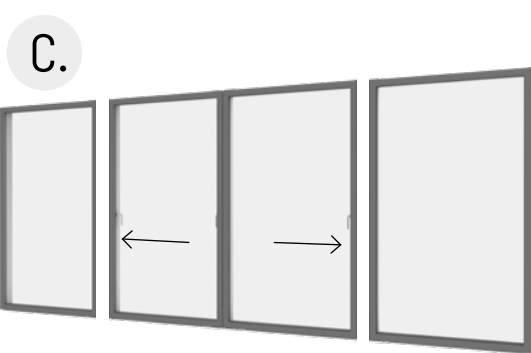

2-leaf sliding door, three separate units

C.

The 2-leaf sliding door delivered as three separate units should be installed removing the aluminium sashes first:

- Desash the fixed units as per below description.
- Desash the opening units as per below description.
- Position the timber mainframes into the fully formed structural opening and couple them together.
- Using suitable lifting gear resash first the opening unit, then the fixed unit assuring correct position of guide rails and carriages.

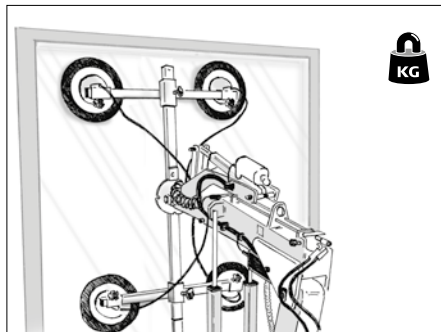

**How to desash the fixed units.**

Secure the sash of one fixed unit with an appropriate lifting gear.



[See video 7:56](#)



Remove the internal cover cap in the top frame using the VELFAC Allen key provided to rotate the tumbler fixing through 90°.

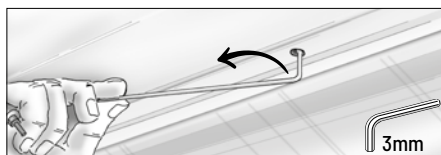

VELFAC Allan key, item no. 62.1167..

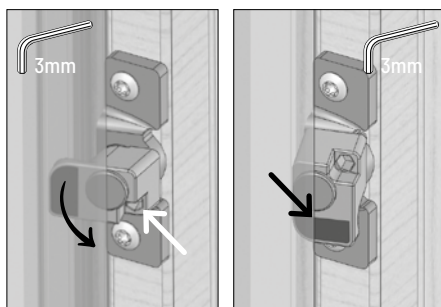

Apply the same process to the tumbler fixings located to the frame perimeter.

NB. The illustration of the tumbler fixings shows them on the right side of an unit seen from the outside. On the left side, they are fitted upside down, so the latch must be turned upwards (anticlockwise).

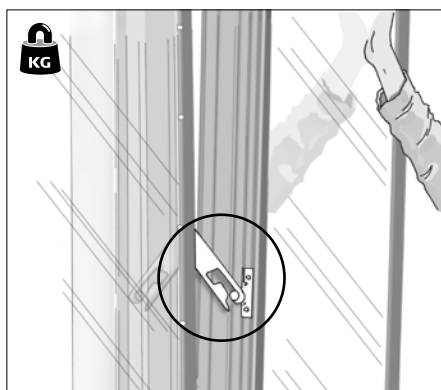

Tilt the frame out at the top. Use the safety catches to hold it at a 25-30° angle.

Ensuring at all times that the sash is safely retained, push the sash inwards releasing the pressure on the safety catches. Then release the safety catch on both sides of the sash by pushing it upwards.

C.

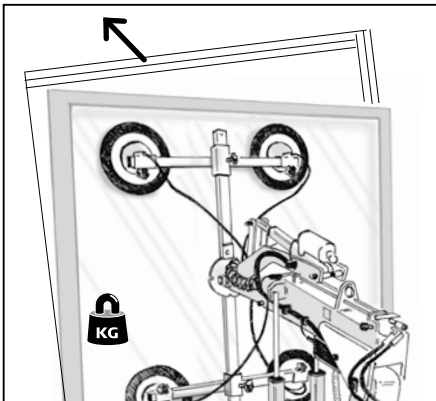

To complete the desashing process gently lift the sash and ...

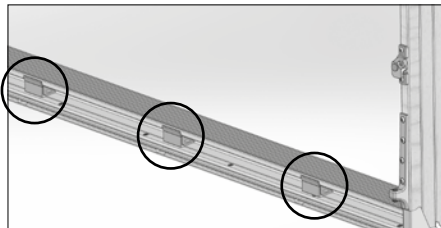

... remove it from the brackets on the threshold.



Store the sash in an upright position leaning on the aluminium sash, packed off of finished floor. Prevent any weight being applied to the plastic profiles that form part of the sash.

Now repeat proces for the other fixed unit.

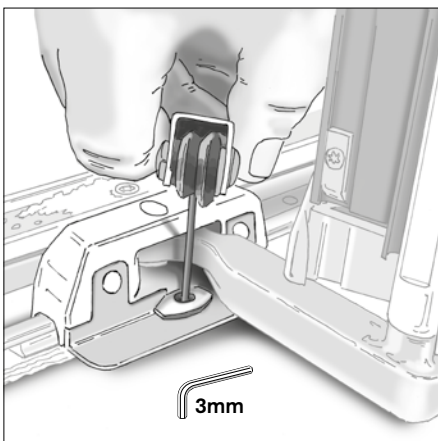

**How to desash the primary opening unit.**

Open the handles of the sash. Pull the sash slightly outwards and slide it to the side so that the sliding door is slightly open.



[See video 9:08](#)

Using a 3mm hex key remove the safety catch in the running track.

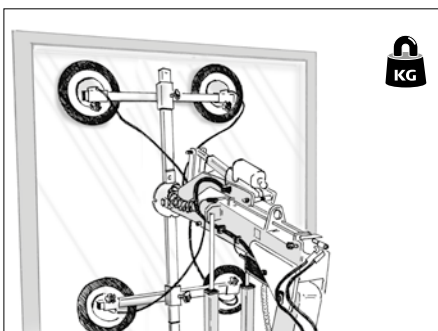

Secure the sash of the opening unit with an appropriate lifting gear.



VELFAC 200 Sliding Casement Door, 24mm Threshold, 2-leaf, separate units, 12/18

C.

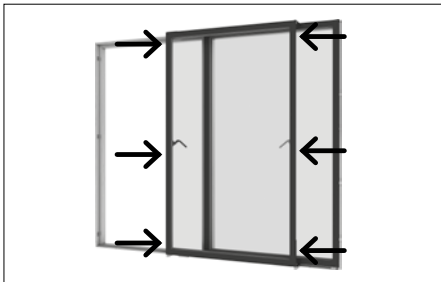

Now free the top slide arms. There are 3 grub screws in the guide rod in both ends of the sash. These secure the top slide arms.

To release the slide arms complete the steps below to both sides of the unit using a 3mm hex key (no. 1-6):

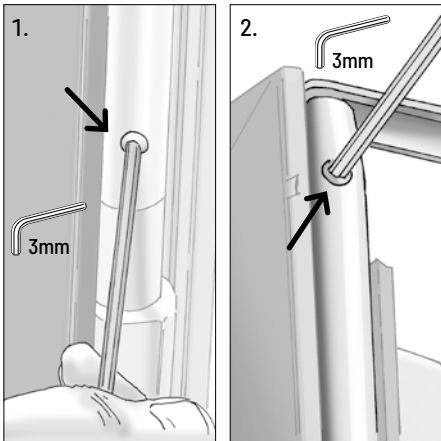

1. To temporary secure the wheeled truck, tighten the middle screw so it is level with the guide rod.

2. Loosen but do not remove the screw located at the top.



3. Loosen but do not remove the screw located at the bottom, this will allow the guide rod to be lifted out and repositioned to the side.

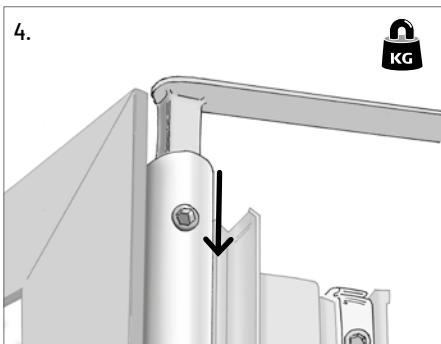

4. Lower the guide rod to release the top slide arm. The frame and sash of the opening unit have now been separated and the frame is ready to be installed (NOTE: section 5-6).

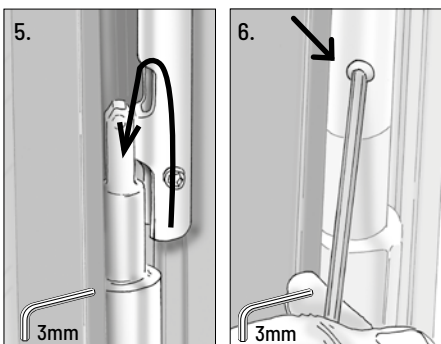

5. Lift the guide rod at both ends of the primary sash into place and re-tighten the tailstock screws at the bottom and top.

6. Finally, loosen the tailstock screw in the middle.

C.

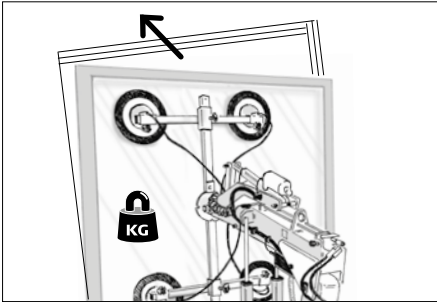

To complete the desashing process gently lift the sash and remove it from the threshold.

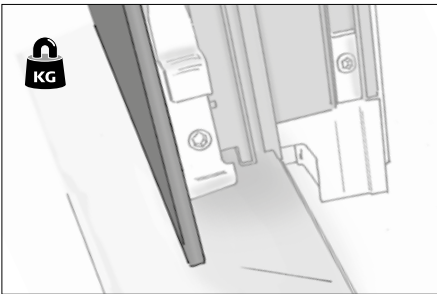

Store the sash in an upright position leaning on the aluminium sash, packed off of finished floor. Prevent any weight being applied to the plastic profiles that form part of the sash.

Now desash the secondary opening unit.

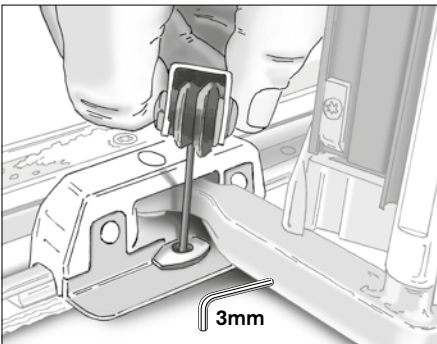

**How to desash the secondary opening unit.**  
Open the handle and release the flush bolt in the mullion of the secondary sash. Pull the sash slightly outwards and slide it to the side so that the secondary door is slightly open.

Using a 3mm hex key remove the safety catch in the running track.

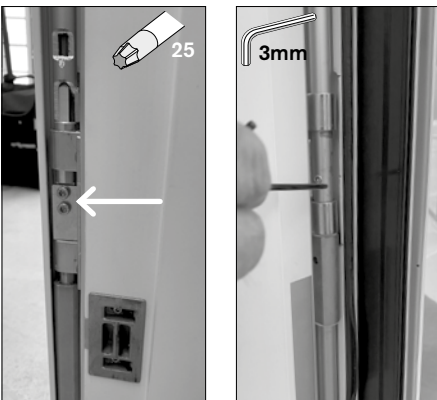

Disengagement of the top slides in the secondary sash should be carried out in the same manner as for the primary sash (sections 1-6, page 41). However, in order to access the tailstock screws in the guide rod of the French casement mullion, you must first remove the locking plate in front of the guide rod using a torx 25 drive. The mullion can then be turned around completely making the tailstock screws accessible.

VELFAC 200 Sliding Casement Door, 24mm Threshold, 2-leaf, separate units, 14/18

C.

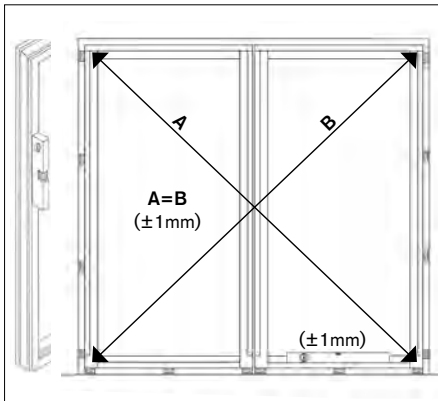

**Installation.** Place the frames in the fully formed structural opening and couple them together. This makes it easier to connect the carriages and top arms.

The frames must be assembled according to the same principles that apply to the fixing of jambs.

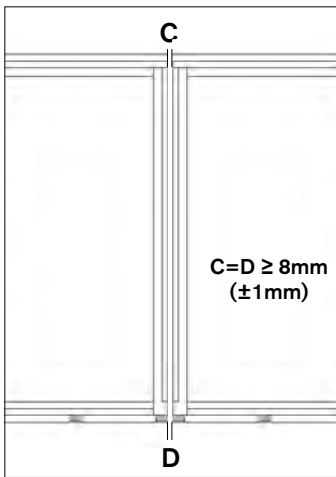

**Tolerances.** Running tracks must be level. Therefore, the spacing between the opening and fixed frame in points C and D must be precisely 8mm with max. 1mm difference between measurement C and D.

The following must be checked before final fixing:

- that the frames are positioned in a completely straight line
- that the frames are plumb and level
- that the diagonal measurements are complied within tolerances
- that the running tracks are level

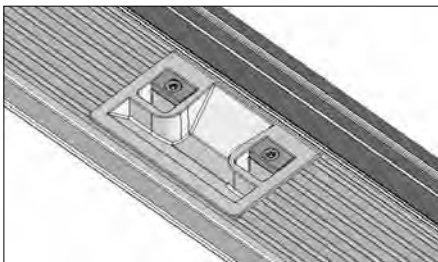

**The aluminum tread-plate.**

To allow fixing through the sliding door threshold the aluminium tread-plate is supplied only partially installed and must be removed prior to fixing.

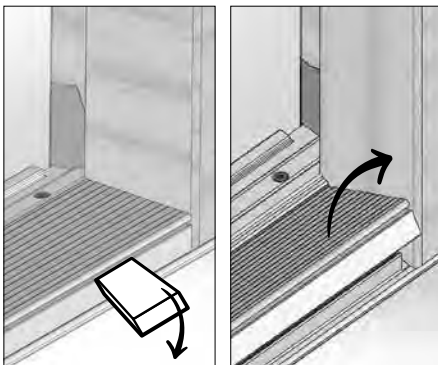

In 2-leaf sliding doors, however, the tread-plate is installed from the factory and should be removed prior to fixing of the unit. Carefully insert a wooden wedge or flat bladed tool into the groove on the back of the tread plate and gently lever downwards un-clipping the section at intermittent points until completely loose.

Carefully remove the tread-plate and set it aside.

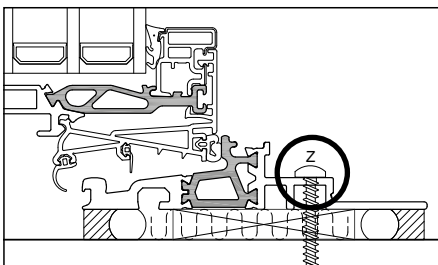

Fixing through the threshold (item Z) must be done vertically into the structure and should be set at maximum centres of 400mm.

When all fixings (Z) have been applied and the sliding units have been checked for functionality, the tread-plate should be positioned and clipped in place.

VELFAC 200 Sliding Casement Door, 24mm Threshold, 2-leaf, separate units, 15/18

C.

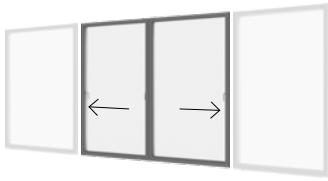

**How to resash the opening units.**

Start with the secondary, followed by the primary sash. Lift the secondary opening glazed sash and reinstate following the below guidance.



Carefully place the sash next to the frame so that it rests on the bracket arms of the carriage.



Lift the frame into place on the threshold, with one carriage positioned on either side of the mullion.



Check that both carriages are positioned correctly on the running track.

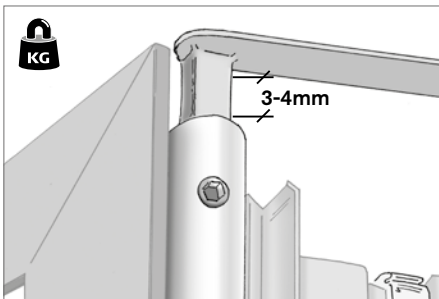

Follow this by reengaging the top slider arm in the guide rod at both ends (sections 1-6, page 41).

NOTE: The top sliders may not touch on the neighbouring sash; they must therefore be installed at a distance of 3-4mm to the guide rod.



The secondary sash only:

On the side of the French casement mullion: turn the mullion into place and reinstate the locking plate using a torx 25 drive.

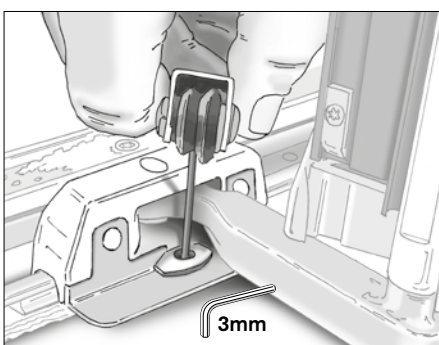

Finish by reinstating the safety catch in the running track.

Now resash the primary sash in the same way

VELFAC 200 Sliding Casement Door, 24mm Threshold, 2-leaf, separate units, 16/18

C.

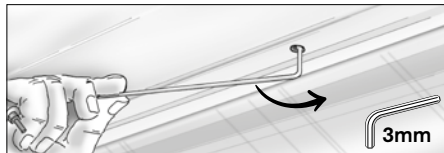
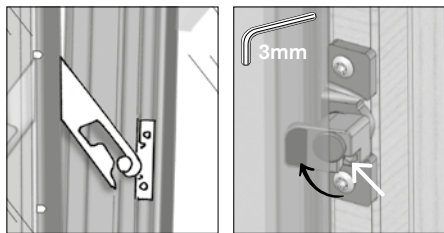
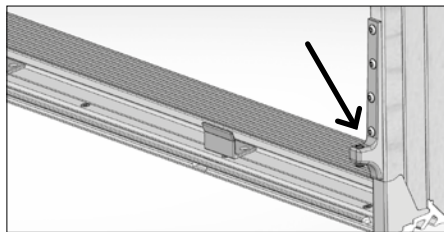
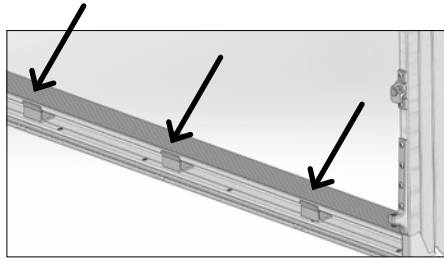

**How to resash the fixed units.**

Always after the opening sashes have been reinstated.

Use suitable lifting gear and position a fixed sash at the bottom:

- Gently lift the sash over the running track and lower it down carefully.
- The retainer brackets in the threshold should engage with the holes in the bottom of the sash.
- The sash should rest on the support arms at the bottom of the frame on both sides.
- Follow this by reinstating the safety catches on both sides so that the sash cannot fall out.
- Press frame and sash together and turn the tumbler fixings located at the perimeter into place.

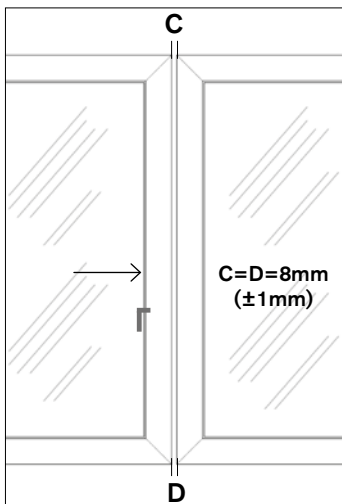

**Check that the sashes are level before final fixing.** Close the sliding casement door and measure the distance between the sashes at the points C and D. The distance between the sashes must be:  $C \geq 8\text{mm}$  and  $D \geq 8\text{mm}$ .

Max 1mm difference between C and D measurements is allowed. Adjust if required and check movement. Failing to adjust may affect the functionality of the door.

C.

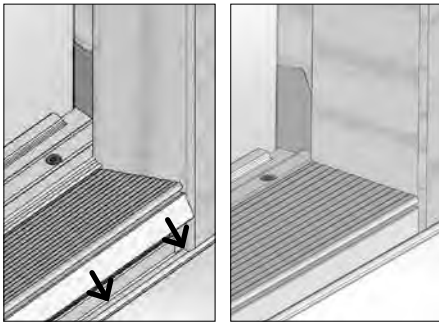

**Reinstating the tread-plate.**

Carefully place the aluminium tread-plate in the slot traversing the length of the threshold, carefully turn and press the tread-plate into position.

May wait until the construction is finished to protect the surface of the tread-plate.

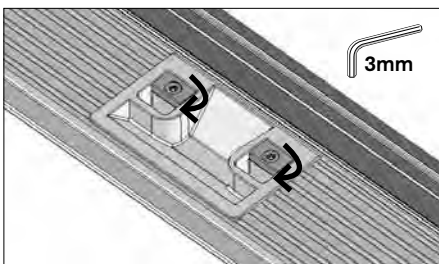

Adjusting the striking place underneath the French casement mullion. Loosen the screws of the striking plate, allowing to take out the adjusting pieces and turn them 180°.

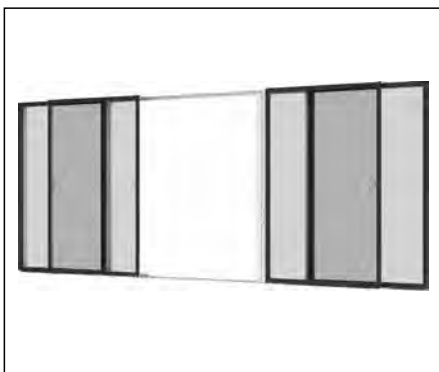

**Check functionality.** The sliding unit should operate smoothly with minimum effort required to open and close. Adjust if necessary.

The sliding door is now ready for use.

A. B. C.



**Sliding Truck Cover Plate.**

The cover plate is fitted from the factory. It is visible from the inside, but is fixed with 2 screws from the outside of the door.

In the event a replacement is required refer to process below:

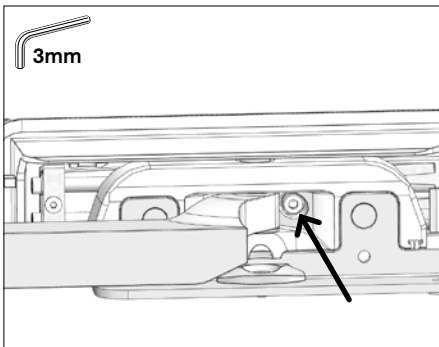

**Removing the Cover Plate.**

1. Open the sliding unit slightly to expose the rear screw on the outside of the door.
2. Using a 3mm hex key remove the screw.
3. Open the sash slightly more so that the arm rotates and the front screw comes into view.
4. Using a 3mm hex key remove the screw and the cover plate is loose.

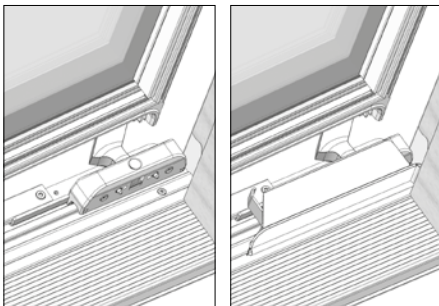

**Reinstatement of Cover Plate.**

1. Open the sliding unit and place the tread-plate on top of the sliding truck.



[See video 4:08](#)

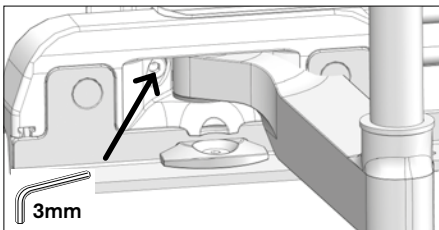

2. The cover plate must be fixed from the outside of the door by means of a screw on both sides of the arm.

3. Start with the screw at the front using a 3mm hex key.

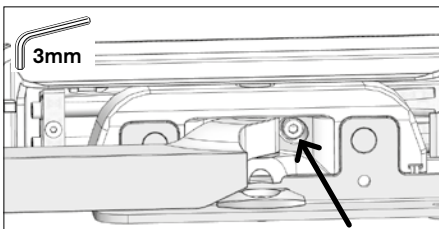

4. Slide the door until it is almost closed exposing the the fixing hole and allowing access for the retaining screw to be re-applied.

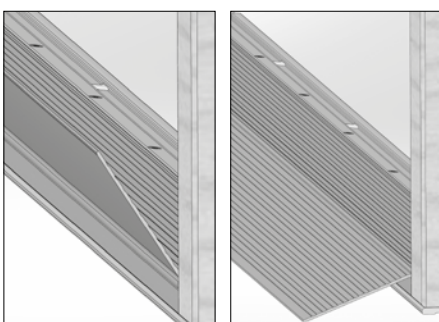

**Installation of Ramp Section (supplied on request).**

Place the ramped section in the groove and pivot downwards.

**General Installation Principles**

- The substrate or fixing ground must be solid and capable of fully supporting the element across its full length and width.
- A folded cill profile should be placed over the exposed external structure and then bonded using Illbruck SP 350 and packed level across the full length of the opening to + / - 1mm while still retaining the required tolerance at the head and cill zone.
- When assembling into the opening packing must be placed directly under all vertical load points and intermittent packing should then be placed at centres no greater than 300mm.
- When positioned / packed correctly there should be a gap no greater than 10mm between the underside of the running track and the top of the folded cill profile.
- At this junction nylon support blocks from Finish Architectural Ltd measuring 10mm deep x 7mm wide x 50mm long should be placed at centres no greater than 300mm and bonded using Illbruck SP 350.
- The blocks should be positioned so as to not impede the drainage paths of the running track.
- **NB the nylon blocks must be positioned and bonded in tandem with the application of the primary wet seal. (Illbruck FS 125).**
- When applying the primary wet seal between the running rail and the top of the folded cill profile it must sit flush with the front of the rail.
- Where factory applied drainage holes occur the wet seal must be set back to allow water to dissipate.

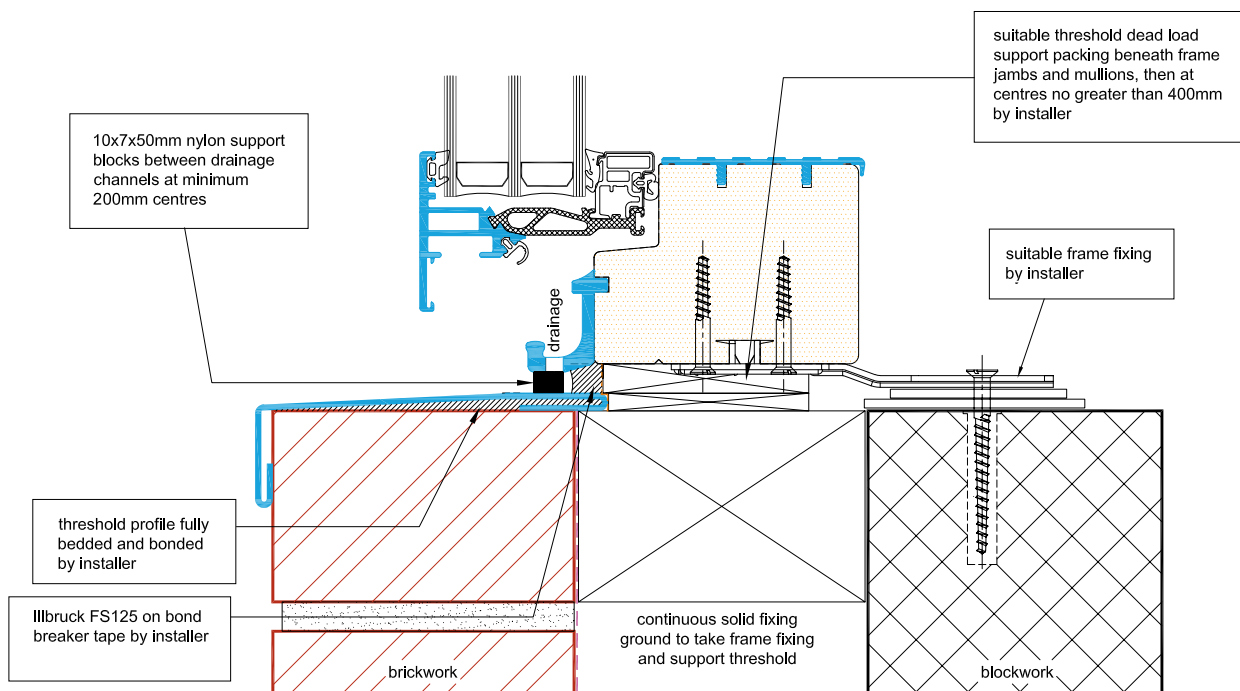

Indicative fixing arrangement for VELFAC 200 ENERGY sliding casement doors with 70mm Threshold



**Mandatory packing points below threshold**

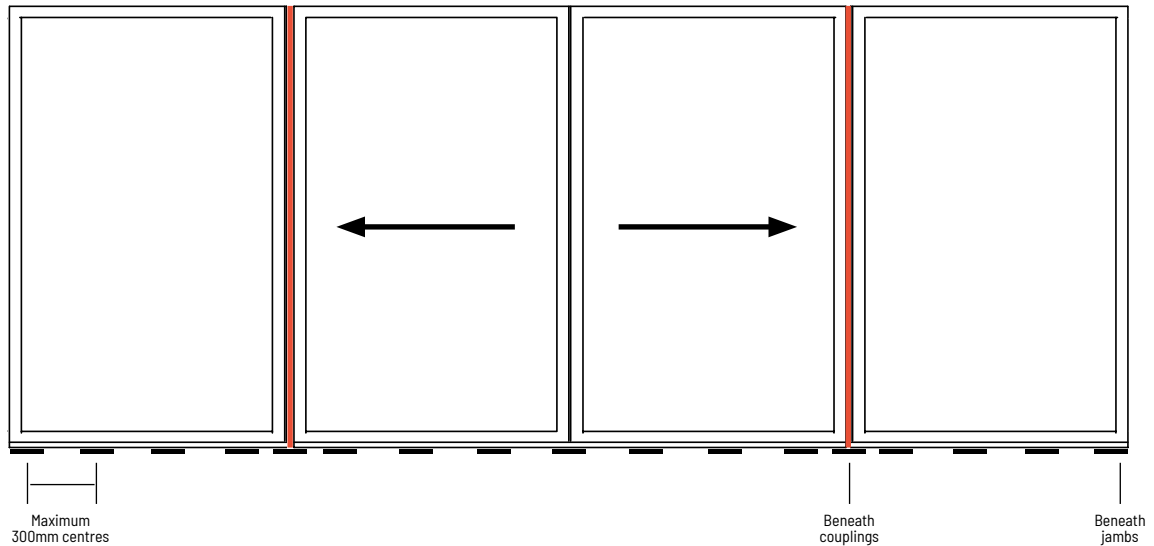

- Upon completion the element must be checked for plumb level and square with any adjustments being undertaken immediately. Externally sash alignment should be checked with the gap between sashes being 8mm (+ / - 1mm).

**Mandatory fixing centres**

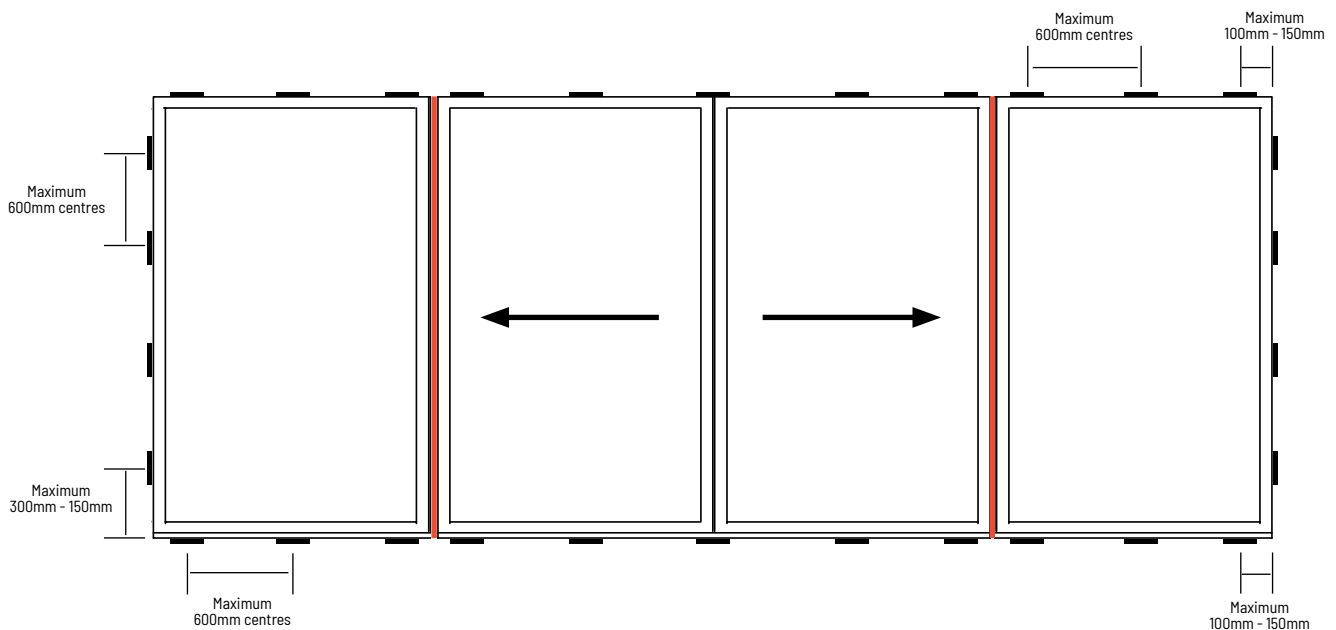

**Watch video**

Prior to installation we recommend to see the video on our YouTube channel: "Tips & Tricks - how to get your sliding casement door with 70mm threshold to run optimally".



[See video](#)

**Coupling principles for 2-leaf Sliding Casement Doors**

For the 2-leaf variant there will be a necessity to build / couple the units together on site. For this purpose, there are two options these are referred to as the:

- Commercial Option
- Domestic Option
- At coupled joints the commercial option consists of a minimum 8mm joint (up to a maximum 16mm) being formed between the units this is done by using proprietary packers with the units then being screwed together at 100-150mm from the top and bottom transom rail then at intermediate centres no greater than 600mm.
- From an internal perspective the joint is then silicone sealed using Illbruck FS 125 while the external joint is sealed using a Illbruck TP600 impregnated foam. The cavity between the seals should be filled using loose fill mineral wool or similar.
- The Domestic Option see a timber T profile being introduced to replace the internal silicone seal, the coupled joint size parameters remain the same ie minimum 8mm maximum 12mm and there are T sections to accommodate this range. The requirement for the external seal and mineral wool fill remains the same.

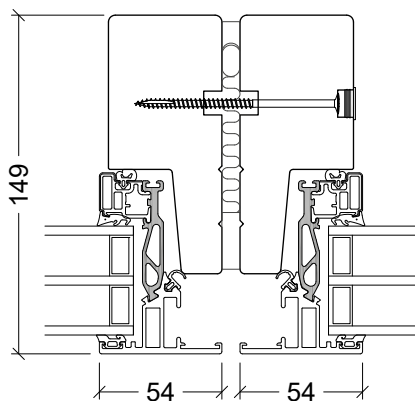

Commercial Option

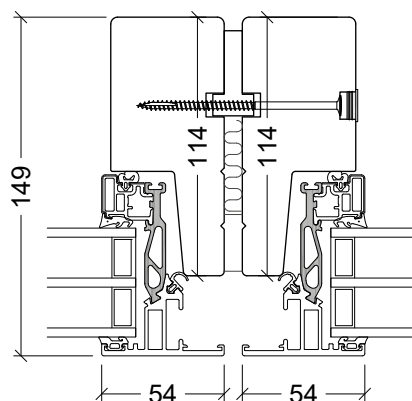

Domestic Option

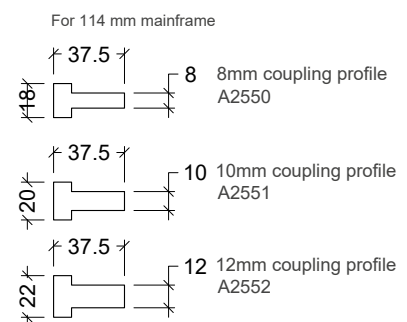

T Section Coupling

VELFAC 200 Sliding Casement Door, 70mm Threshold, Installation Tips, 1/6

A. B. C.

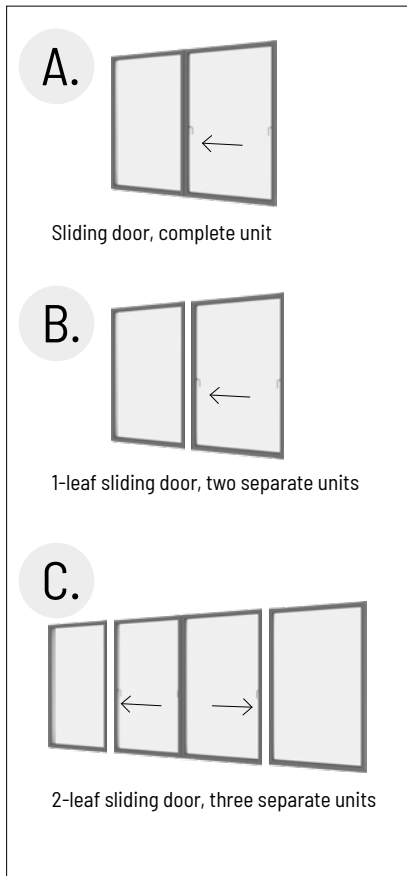

**Delivery to site.** There are three configuration options for a sliding unit:

- A. 1-leaf sliding door as a complete unit
- B. 1-leaf sliding door as two separate units or
- C. 2-leaf sliding door as three separate units.

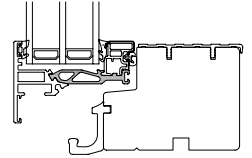

**Packing and positioning in structural openings,** which is described on the following pages (pages 51-52), applies to all three types (A+B+C).

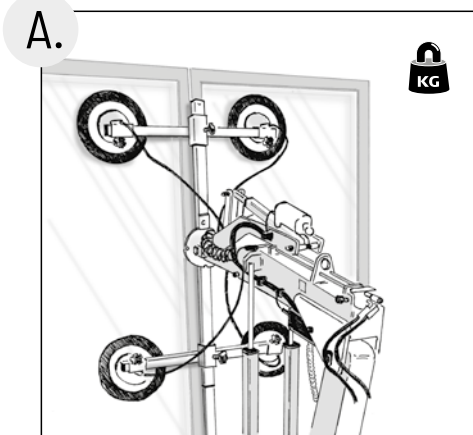

**Starting tips:**

**1. For configurations A, B and C:** For all configurations to allow a successful installation clear unhindered access is required both externally and internally, as packing for dead load, adjustment and coupling of sashes cannot be carried out from the inside only.

**2. For configuration A:** If the sliding door is delivered as a complete unit, it can be positioned into the fully formed structural opening by means of the site-specific lifting/handling method. NOTE: Always lift both sashes.

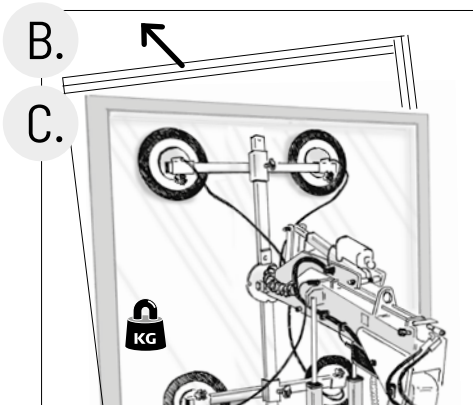

**3. For configurations B and C:** If the sliding door is delivered as 2 or 3 units, each unit must be desashed, before the frames are placed and coupled together in the fully formed structural opening. This makes it easier to connect the carriages and top arms.

A. B. C.

**4. For configurations A, B and C:**

Accurately installed frames will require fewer adjustments!

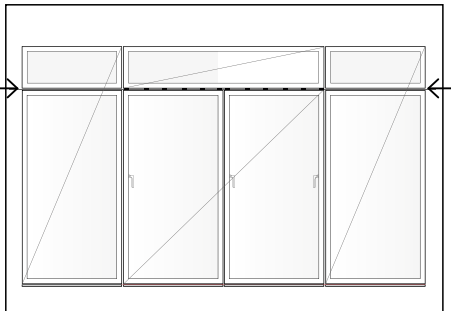
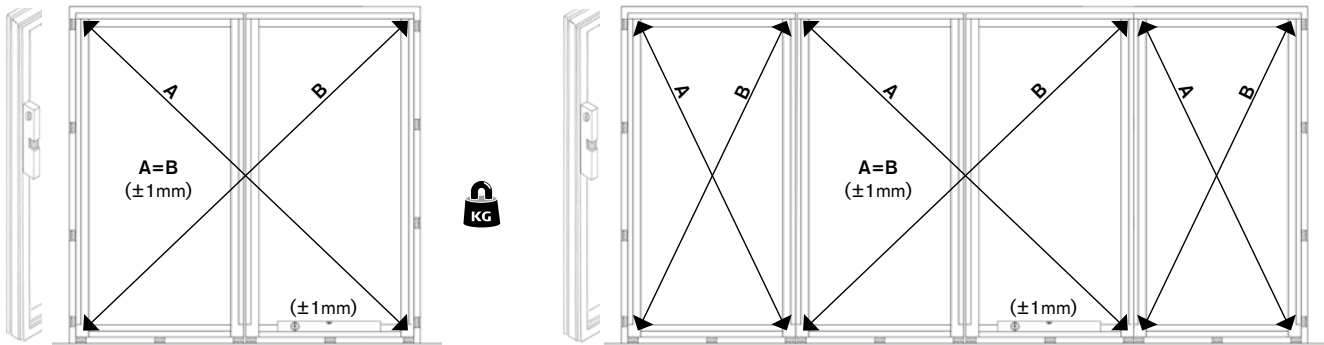

**5. Transoms.** Any transoms in 2-leaf units must be installed as self-supporting structures. Insert, e.g. steel lintels. Loads placed on the sliding door by transoms will inhibit its ability to work optimally.



**6. Check functionality.** The sliding unit should operate smoothly with minimum effort required to open and close. Adjust if necessary please see the VELFAC 200 Desash and Adjustment Guide.

VELFAC 200 Sliding Casement Door, 70mm Threshold, 1-leaf, complete unit, 3/6

A.

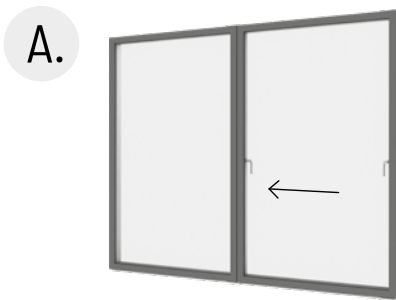

1-leaf sliding door, complete unit

The 1-leaf unit can be installed without the need to remove the aluminium sashes from their mountings as adjustments have been undertaken during the manufacturing process.

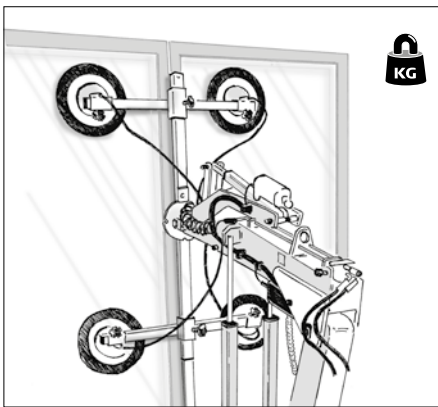

Position the sliding door into the fully formed structural opening with suitable lifting gear,

NOTE: If using mechanical lifting aids apply to both sashes.

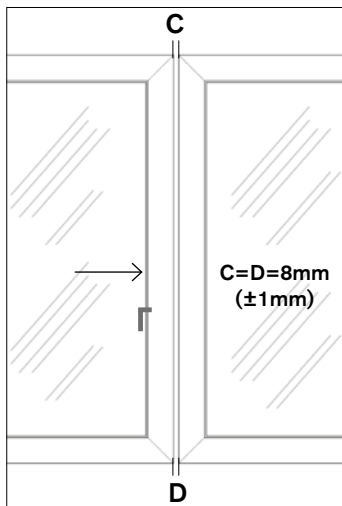

**Tolerances.** Close the sliding casement door and measure the distance between the sashes at the points C and D. The distance between the sashes must be:  $C \geq 8\text{mm}$  and  $D \geq 8\text{mm}$ .

Max 1mm difference between C and D measurements is allowed. If the result is not within the tolerance limit, adjust the installation of the frame. Otherwise the operation of the sliding door will work poorly.



**Check functionality.** The sliding unit should operate smoothly with minimum effort required to open and close.

The sliding door is now ready for use.

VELFAC 200 Sliding Casement Door, 70mm Threshold, Installation Tips, 4/6

**B.** **C.**

**B.**

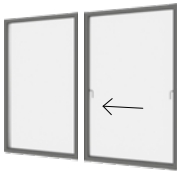

1-leaf sliding door, two separate units

**C.**

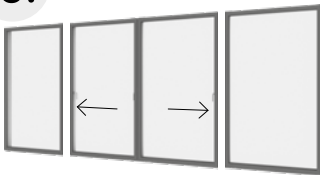

2-leaf sliding door, three separate units

Installation of a 1-leaf sliding door delivered as two separate units, as well as a 2-leaf sliding door delivered as three separate units should be installed removing the aluminium sashes first:

- Desash the fixed unit(s) as per below description.
- Desash the opening unit(s) as per below description.
- Position the timber main frames into the fully formed structural opening and couple them together.
- Using suitable lifting gear resash first the opening unit(s), then the fixed unit(s) assuring correct position of guide rails and carriages.

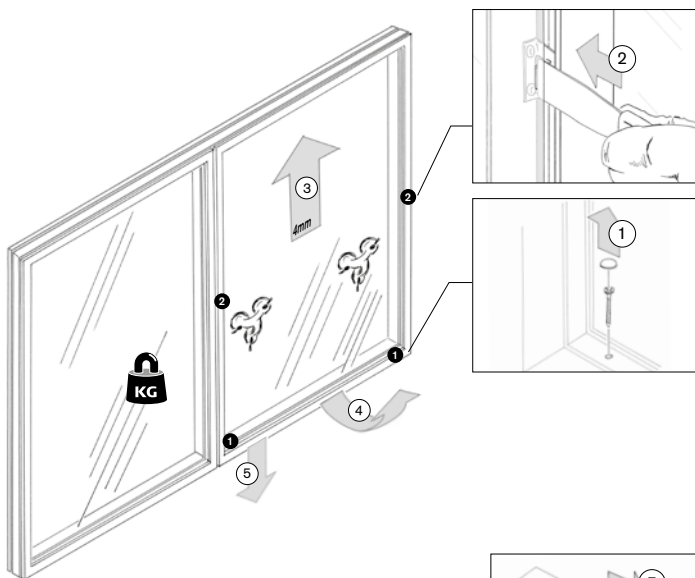

**How to desash the fixed DOUBLE GLAZED unit.**

1. Remove the internal cover cap with a flat bladed tool.
2. Push the fittings located on the jamb with a flat bladed tool to release them.
3. Support the sash and lift it approx. 4mm upwards,
4. Follow this by tilting it outwards at the bottom,
5. Complete the operation by lowering the sash down.

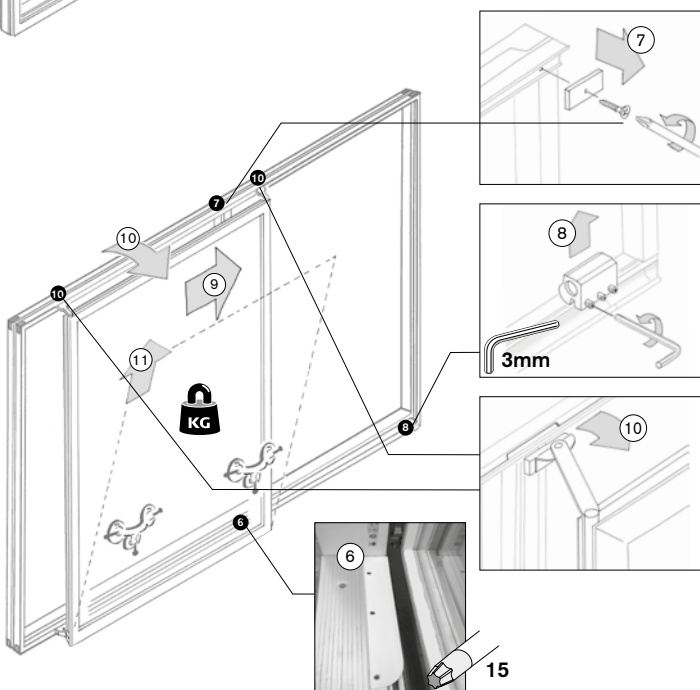

**How to desash the opening DOUBLE GLAZED unit.**

6. Using a torx 15 drive remove the anti-derailer lock at the threshold.
7. Using a torx 15 drive remove the anti-derailer lock at the head.
8. Using a 3mm hex key loosen and move the stop block backwards.
9. Slide the opening sash over the fixed sash until the top brackets are close to the recesses in the head.
10. Fully support the sash, slide it to the recesses at the top and tilt it out.
11. Lift the sash upwards and lower it down.

**B. C.**

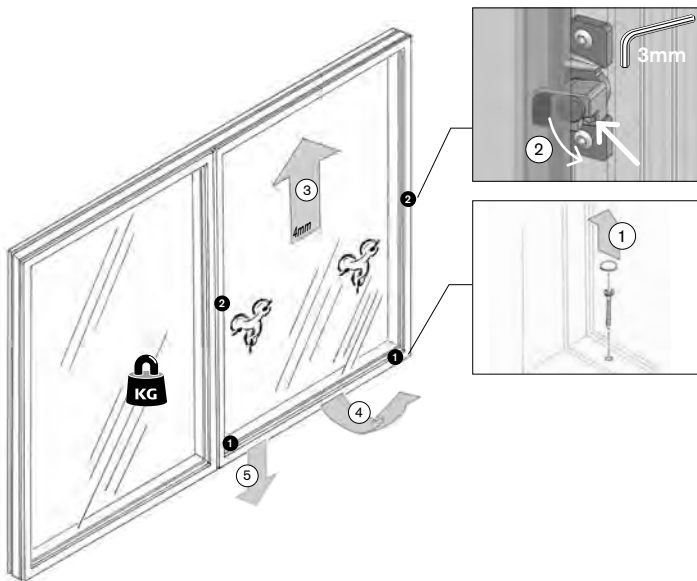

**How to desash the fixed TRIPLE GLAZED unit.**

1. Remove the internal cover cap with a flat bladed tool.
2. Using a 3mm hex key loosen the tumbler fittings located on each jamb: Press sash and frame together, firmly place the Allen key in the fitting and free the sash by turning each tumbler fitting 90° anticlockwise.
3. Support the sash and lift it approx. 4mm upwards,
4. Follow this by tilting it outwards at the bottom,
5. Complete the operation by lowering the sash down.

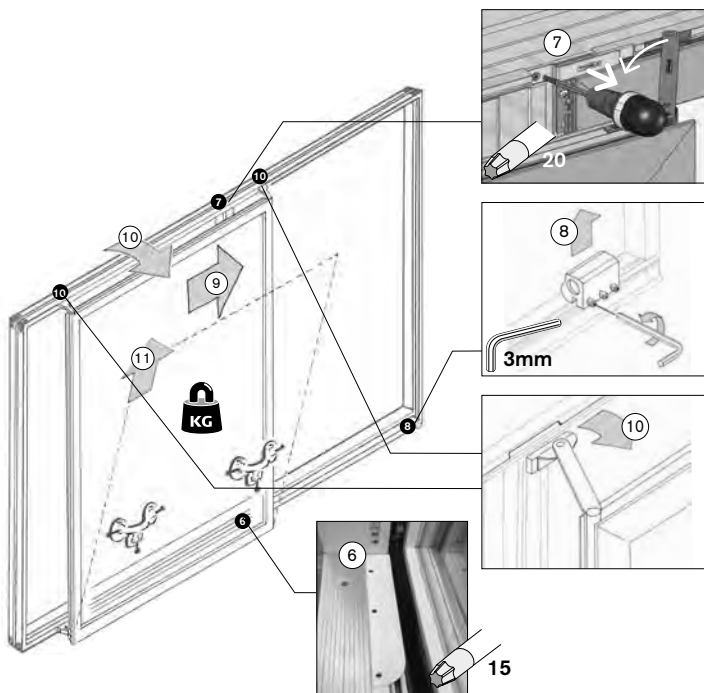

**How to desash the opening TRIPLE GLAZED unit.**

6. Using a torx 15 drive remove the anti-derailer lock at the threshold.
7. Using a torx 20 drive remove the anti-derailer lock at the head.
8. Using a 3mm hex key loosen and move the stop block backwards.
9. Slide the opening sash over the fixed sash until the top brackets are close to the recesses in the head.
10. Fully support the sash, slide it to the recesses at the top and tilt it out.
11. Lift the sash upwards and lower it down.

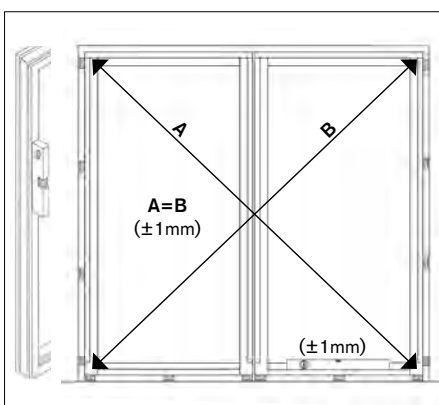

**Installation DOUBLE and TRIPLE GLAZED units.**

Place the frames in the fully formed structural opening and couple them together. This makes it easier to connect the carriages and top arms.

The frames must be assembled according to the same principles that apply to the fixing of jambs.

VELFAC 200 Sliding Casement Door, 70mm Threshold, Installation Tips, 6/6

**B.** **C.**

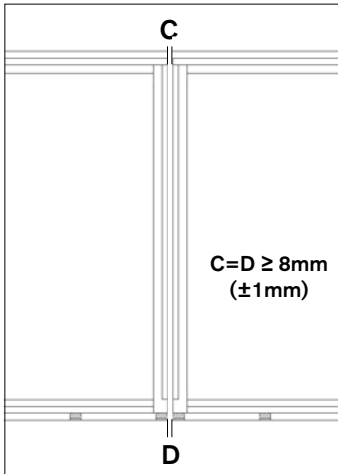

**Tolerances.** Running tracks must be level. Therefore, the spacing between the opening and fixed frame in points C and D must be precisely 8mm with max. 1mm difference between measurement C and D.

The following must be checked before final fixing:

- that the frames are positioned in a completely straight line
- that the frames are plumb and level
- that the diagonal measurements are complied within tolerances
- that the running tracks are level

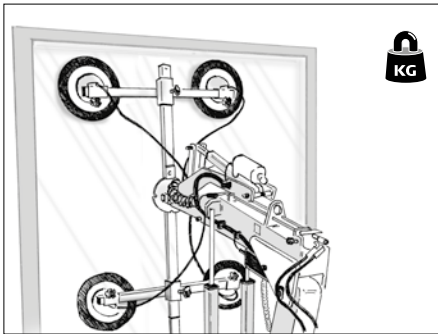

**Now resash the sliding casement door units.**

Using suitable lifting gear resash first the opening unit(s), then the fixed unit(s) assuring correct position of guide rails and carriages.

Resashing is undertaken in the exact reverse order of desashing (please see pages 54-55).

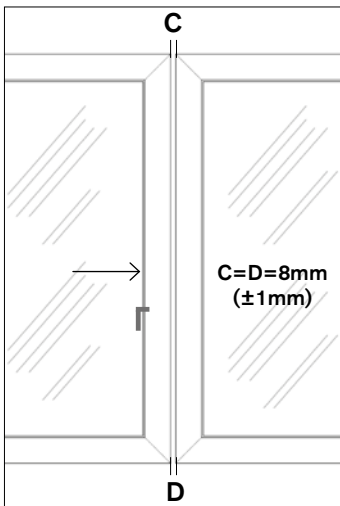

**Check that the sashes are level before final fixing.** Close the sliding casement door and measure the distance between the sashes at the points C and D. The distance between the sashes must be:  $C \geq 8\text{mm}$  and  $D \geq 8\text{mm}$ .

Max 1mm difference between C and D measurements is allowed. Adjust if required and check movement.

Failing to adjust may affect the functionality of the door.



**Check functionality.** The sliding unit(s) should operate smoothly with minimum effort required to open and close.

The sliding door is now ready for use.



VELFAC 200 / Rainscreen Panels

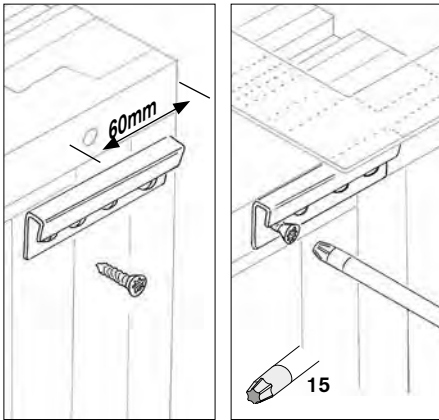

**Installation of separate panels:** Using a torx 15 drive screw in the fitting at the top, ensuring that it sits flush with the edge of the head.

**Panels on a VELFAC frame** must be installed as a VELFAC 200 window.

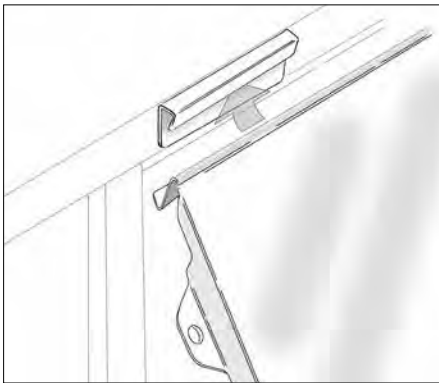

Push the panel up beneath the fitting. Adjust sideways.

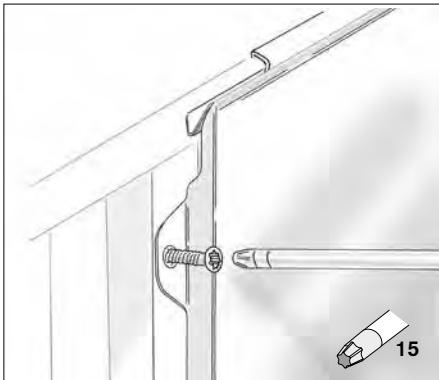

Press the panel against the frame and using a torx 15 drive tighten the screws at an angle of slightly less than 90°. Factory applied screws must be reinstated if they are removed for access purposes.

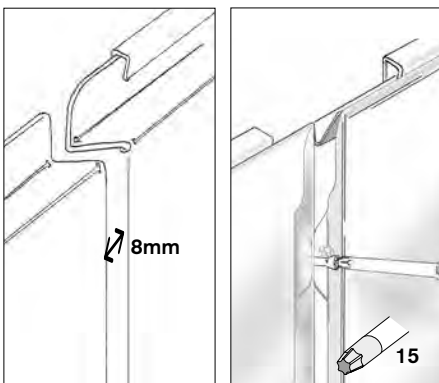

Using a torx 15 drive install the next panel in the same way with 8mm space from the first panel.

## VELFAC 200 / Installation of Drip Flashing 1/2

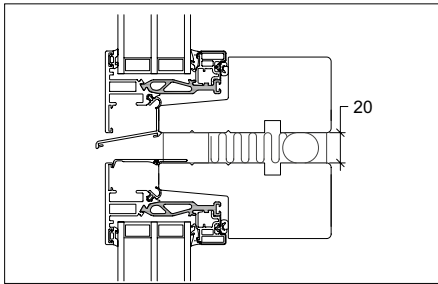

**Purpose.** To allow displacement of water and prevent drainage paths from being overwhelmed on large assemblies horizontal drip flashings are positioned at 3metre intervals. At these locations the horizontal joint will be minimum 16mm.

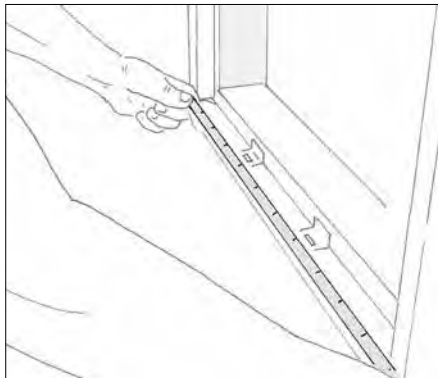

**Measure** the desired length of a drip flashing, e.g. window width.

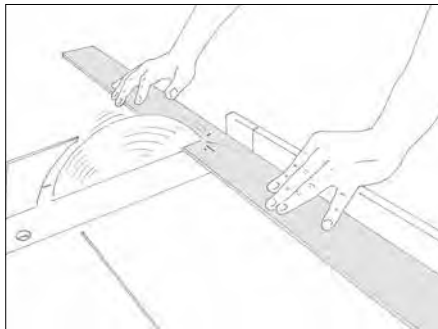

**Cut** the drip flashing in desired length (right angle). In window bands drip flashings may be used in full length across couplings.

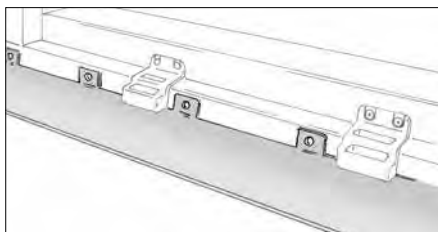
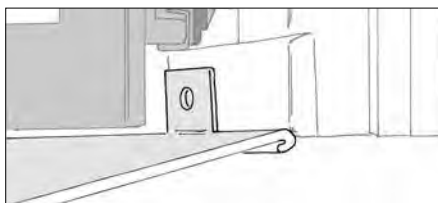

Drip flashings have a castellated tongue to allow multiple fixing points using a 4mm x 20mm stainless steel pan head woodscrew. They are to be fixed on the curved lower edge of the front of the cill (4x20mm screws). Sashes may be opened before installing the drip flashing.

## VELFAC 200 / Installation of Drip Flashing 2/2

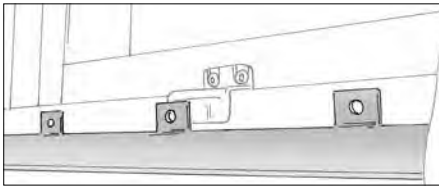

Where a tongue conflicts with factory fitted hardware this can be removed using pliers or a similar tool.

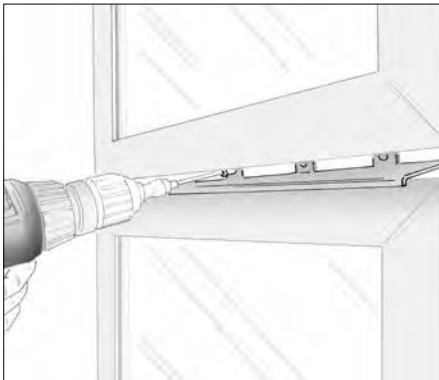
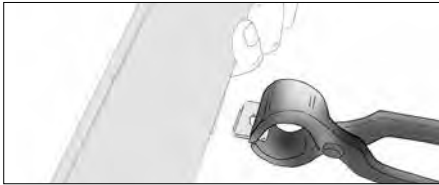

**Fixing.** Use a cordless screwdriver with a long magnetic bit drive and taking care not to damage the paint surface of either sash or drip apply the fixings. Protect the surface of sash and drip flashing by fitting a piece of tube around the bit.

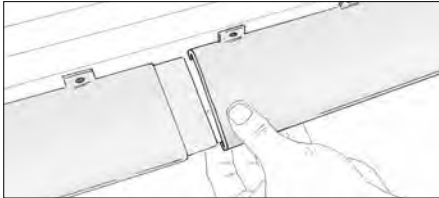

When applying drip flashings across a large facade these can be jointed using a coupling plate (item no. 52.1075), this will ensure alignment.

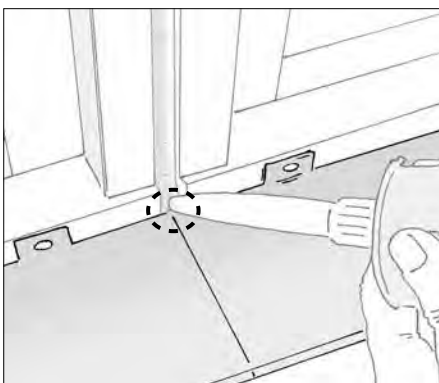
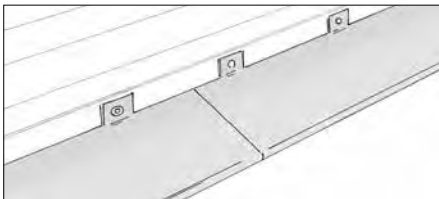

Where the drip flashings passes over a vertical seal the gap between the seal and the back of the drip flashing must be sealed with wet seal application.

# VELFAC 200 / Acoustic Trickle Vent (in Packer)



**Installation:** VELFAC acoustic vents are delivered separately for on site installation. Please follow these instructions in order to fully weather seal and install the vents, and the complete element correctly.

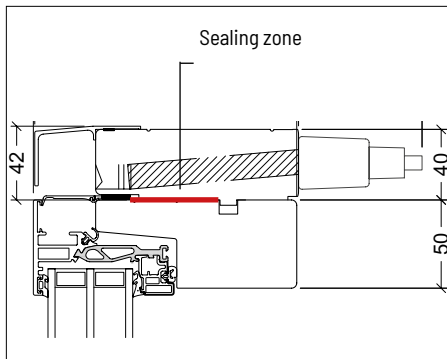

1. The acoustic vent packer should be exactly the same length as the window element.
2. On top of the window there is a single groove within the timber section that acts a locator for the Acoustic trickle vent.
3. In front of the groove the timber section is flat at the highlighted location apply a continuous unbroken bead of Illbruck FS125 to the entire length.
4. Place the packer on top of the window ensuring that the tongue and groove align correctly.

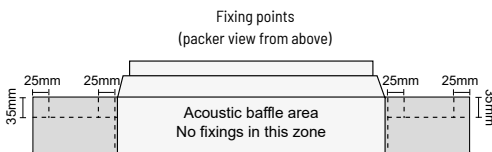

**5. Apply fixings as per the detail:**

- All fixings should sit on a line 35mm in from the back of the trickle vent packer with the first fixing positioned 25mm in from the end.
- A second fixing should be placed on the same line 25mm in from the edge of the trickle vent hood.
- Intermediate fixings can then be placed if required at centres no greater than 450 mm.
- Screw size required is 6mm x 65mm, bright zinc plated (wood screw).
- Fixings **MUST** not be placed in the baffle zone area.

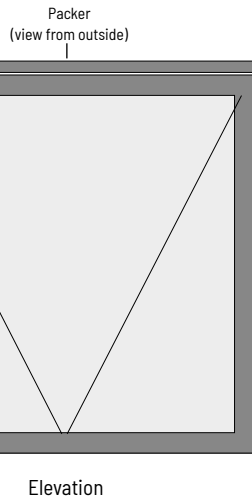

**VELFAC 200 (DGU)**

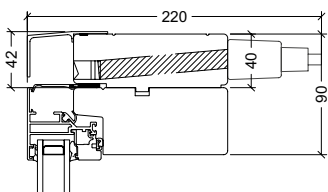

Installed on 115mm mainframe

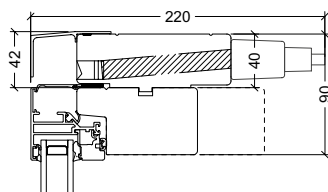

Installed on 90mm mainframe

**VELFAC 200 ENERGY (TGU)**

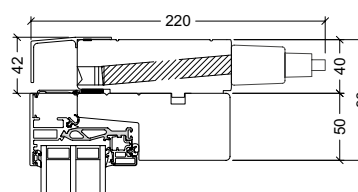

Installed on 114mm mainframe

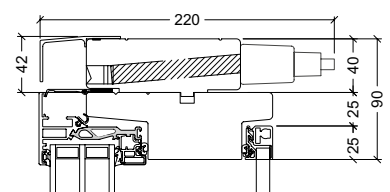

Installed on 3 + 1 window solution

VELFAC 200 / With motor



Care should be taken not to penetrate any zones containing motors, these are clearly marked at point of manufacture by the application of an adhesive sticker.

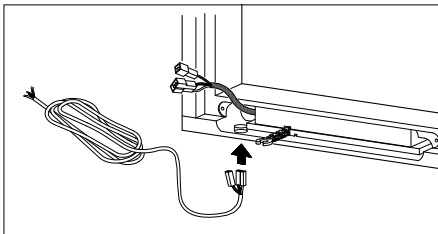

Before placing an element into a window assembly the tail wire (5 metres) supplied with the window should be connected to the motor. Follow the guide, which can be found in the bag.

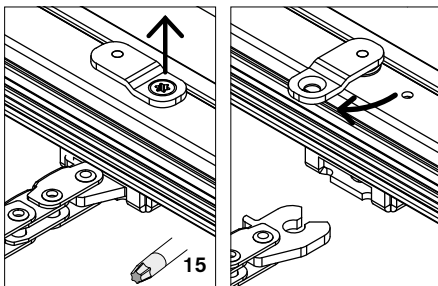

**Release the chain from the sash:** Never release the chain- while the window is closed. Wire it out slightly, then remove the screw and turn the bracket 90°. Pull the sash out of the chain.

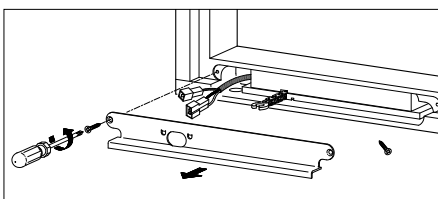

The face plate in front of the motor can now be removed and the wires connected, cf. the enclosed guide.

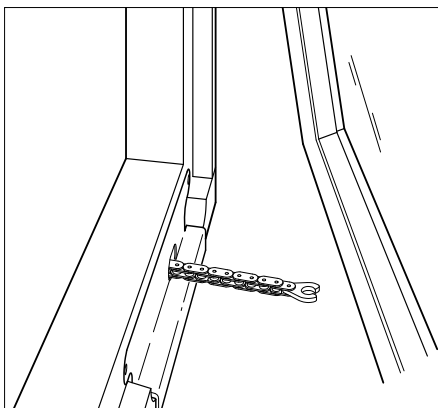

**Remounting of chain:** connect the wires to the terminals of a battery (24V, DC), pull the chain slightly out and re-connect it to the sash.

In the event of functionality issues during installation, please contact the DOVISTA Aftersales department.

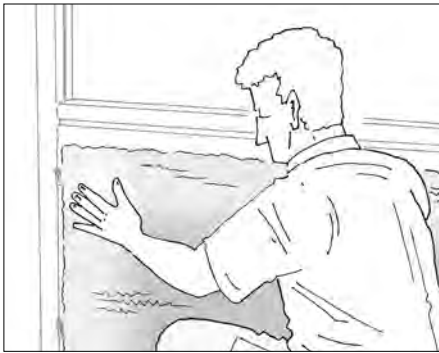

**Mounting the backboard:** the cavity with a material that meets the project specification, please note insulation is not supplied by VELFAC.

**NB.** A vapour barrier is integrated with the backboard.



Place the backboard in the frame and tilt it in place.

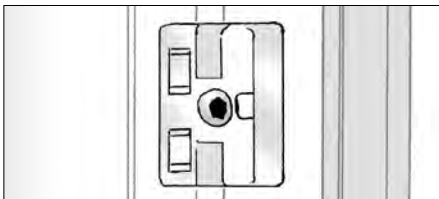

Clips are factory fitted.



After ensuring all the clip fittings are in place, knock the backboard in to place using a rubber mallet.

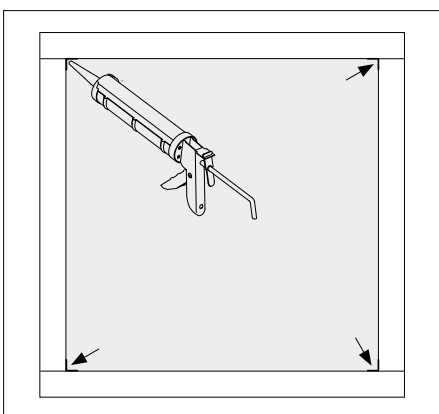

Apply a silicone bead approximately 20mm long both vertically and horizontally on both sides of all corners to assure tightness. The sealant should be pointed afterwards.

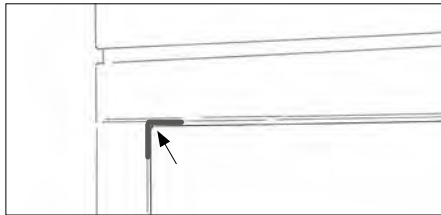

Cut the sealant in all corners (2cm on both sides).

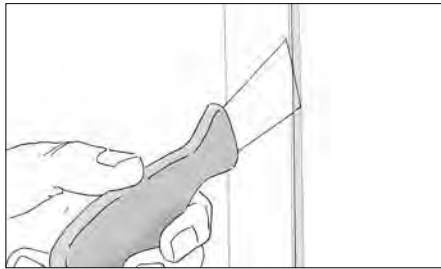

Carefully force flat bladed tool between the frame and the backboard seal.

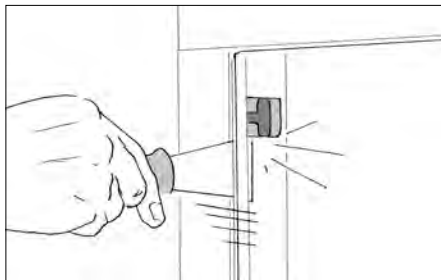

Move tool up or down to locate the fixing clip positioned closest to the corner.

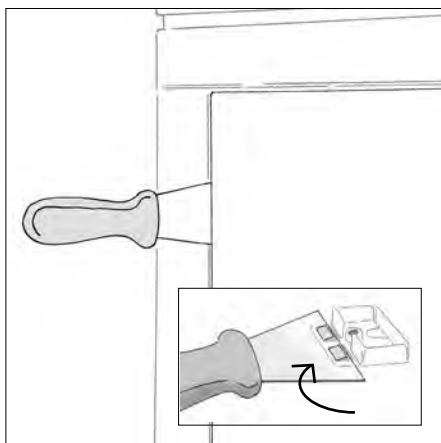
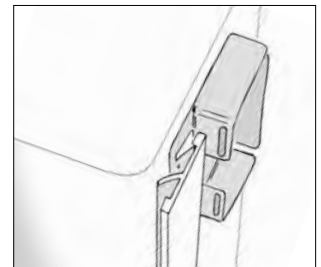

Pull back flat bladed tool slightly and move it in front of the clip. Push forward to release the barb of the clip and leave in place.

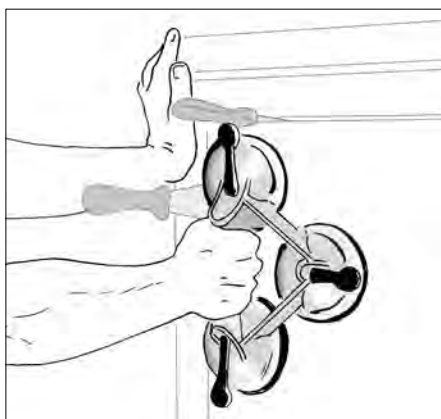

Complete the same process on the adjacent corner. Using a hand held sucker pull the corner free.

Using the same method disengage the balance of the clips, these are positioned at approximate 400mm centres.

# VELFAC Ribo Inward/Outward Opening Doors, Fixing Methods, 1/2



## Entrance and Patio Door Element Fixing

Door elements are generally lug fixed.

- Outward opening doors: use the standard VELFAC twist in lug.
- Inward opening doors: use a pressed metal bracket with a minimum thickness of 3mm; an indicative example is shown below. The length of the bracket should take into consideration the overall depth of the build the element is being placed into to ensure a viable fixing location can be achieved.

For both types of brackets the screws used to fix these to the outer frame work of the doorsets should be 5mm x 40mm bright zinc plated countersunk woodscrew.

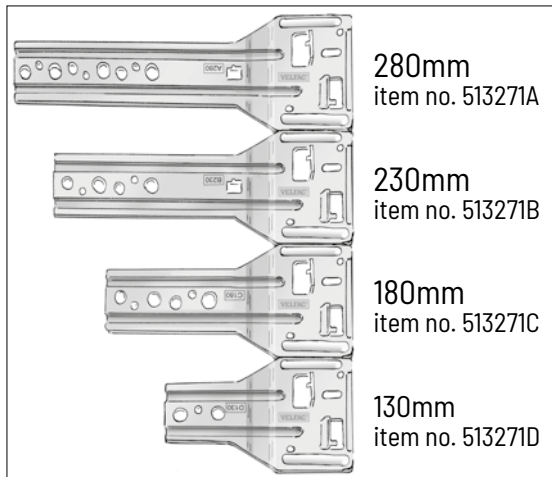

VELFAC standard twist in lug for Outward opening

### Staggered fixing restraint brackets size schedule:

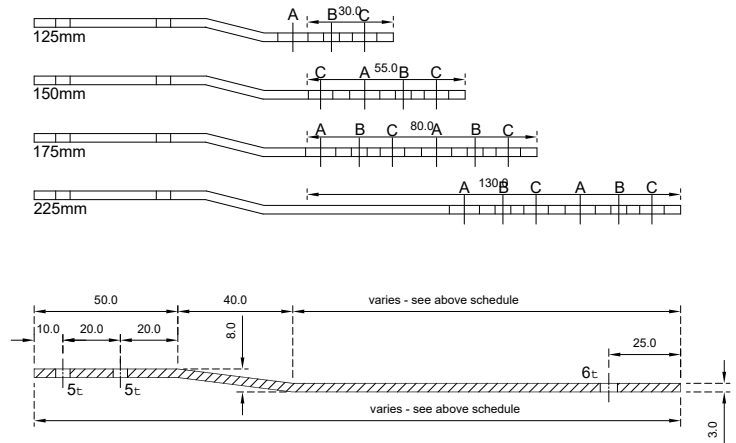

Section - staggered fixing

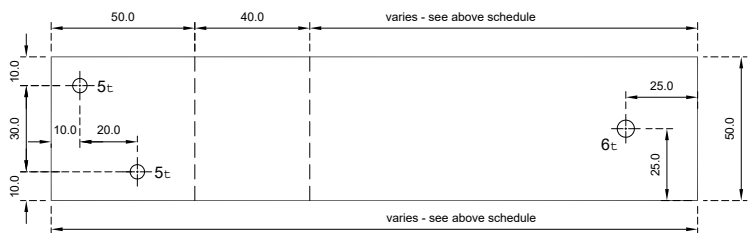

Plan - staggered fixing

Pressed metal lug for Inward opening



## VELFAC Ribo Inward/Outward Opening Doors, Fixing Methods, 2/2



### Lug Positions and Centres

- A single door averaging approximately 900mm wide will require a minimum of 2no fixing brackets at the head set at 150mm from each corner.
- Jamb brackets are located 100mm from each corner with a further bracket at mid-point and any required intermediate brackets set at centres no greater than 450mm.
- A double doorset averaging approximately 1800mm in width will require 2no fixing brackets at the head set at 150mm from each corner with a bracket also positioned at mid-point, further intermediate brackets should be set at centres no greater than 450mm.
- Jamb bracket locations and centres follow the same principle as the single door.
- Maximum set back dimension for a VELFAC Ribo door element on a standard 100 / 100 / 100 construction is 70mm.
- This is on the proviso that the build is complete and in good order, where the build is poor the element can be pulled forward but must retain a minimum 20mm set back.

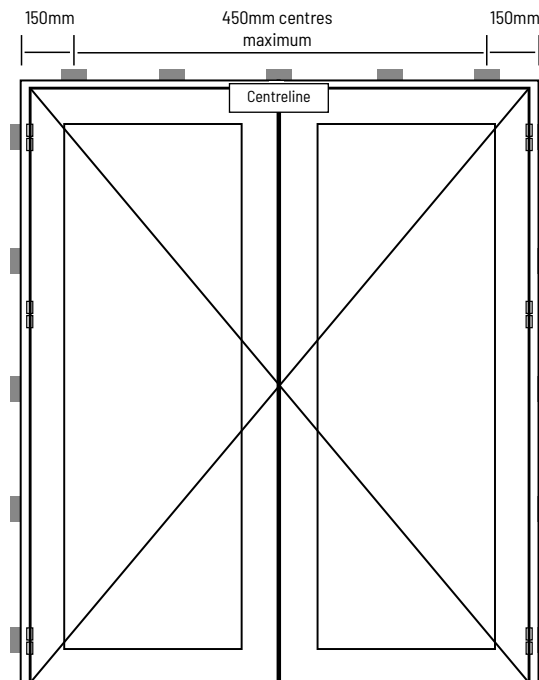
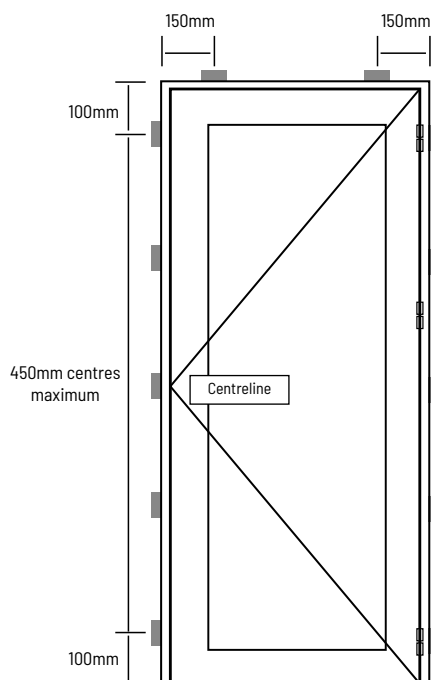
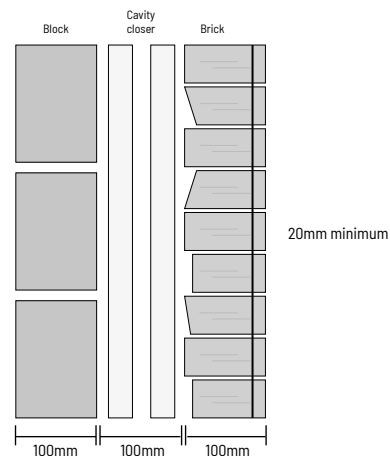
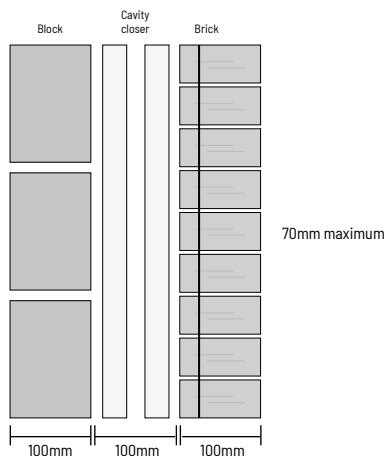

# VELFAC Ribo Inward/Outward Opening Doors, Installation Best Practice



## Stage 1

- Apply two beads of Illbruck SP 350 to the front and rear of the external brick / structure.
- If applicable bed down the threshold cover profile onto the Illbruck SP 350, pack to gain level if required, keep packing to a minimum to ensure contact between bonding agent and underside of threshold plate is maintained.
- Apply two beads of Illbruck FS 125 to the area of the cover profile where the door threshold will sit.

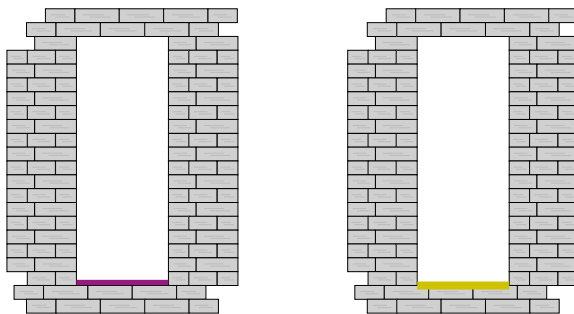

## Stage 2

- Lift the door element into the opening and pack centrally at the base of the jambs ensuring the required set back is achieved on both sides.
- Plumb up and pack close to the top of the jamb.
- Check position is correct and apply fixings at the top and bottom jamb locations.
- Check again for plumb, adjust if required apply balance of fixings.
- Check door functionality.

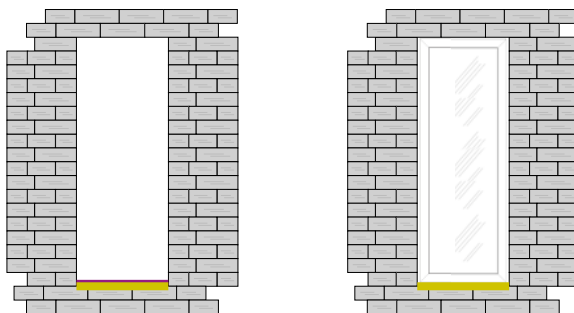

## Stage 3

- Apply perimeter seals and allow a cure period before applying Illbruck FM330 PU Foam inner air seal.
- Check door functionality.

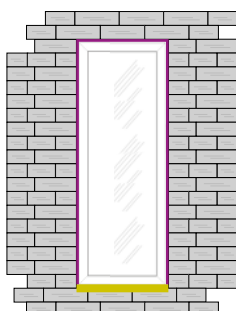

## VELFAC Ribo Inward/Outward Opening Doors, Installation Tips, 1/2

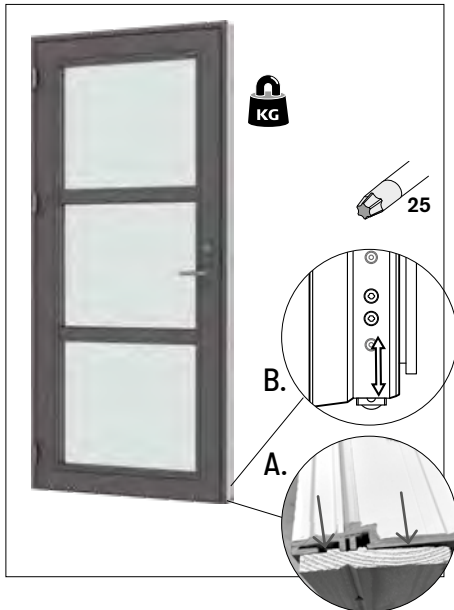

**Prior to installation.** At point of manufacture a timber transit packer (A) is placed under the threshold to assist support during transit. Prior to installation this should be removed. Pack and insulate the door instead to avoid rot.

**The sash lift pulley wheel (B).** To support the sash and assist in functionality there is a sash lift pulley wheel that can be adjusted up or down using a Torx 25 drive.

To activate the door leaf should be opened, the exposed screws should be loosened so the wheel drops and becomes visible.

The top screw should then be tightened and the door closed. Check to ensure the wheel is supporting the door when in the closed position.

Open the door and tighten the remaining screw.



**Hardware.** For transportation purposes hardware such as handles, cylinders, door closers etc are delivered to site loose for site installation. Installation instructions for all components are also supplied.

Further instruction is also available by viewing website videos.



[See video](#)

**TIP cylinder:** Make sure the arrow in the cross in the lock box is pointing downwards on both sides of the lock box before inserting the cylinder.



To ensure weather tightness and functionality a gasket kit and installation instructions for each handle and cylinder is provided. These must be installed, or any warranty claims for drafts and or water ingress at this point will not be valid.



[See video 0:10](#)

**TIP:** Further instruction is also available by viewing website videos.

# VELFAC Ribbo Inward/Outward Opening Doors, Installation Tips, 2/2

## Standard measures and milling

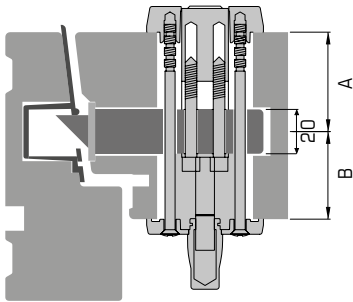

A = External measure

B = Internal measure

	A	B
<b>Outward opening</b>	41.5mm	38.5mm
<b>Inward opening</b>	38.5mm	41.5mm

**Third party handle/rosettes.** If you are fitting a third party handle and rosettes, you must ensure they match the dimensions chart below.

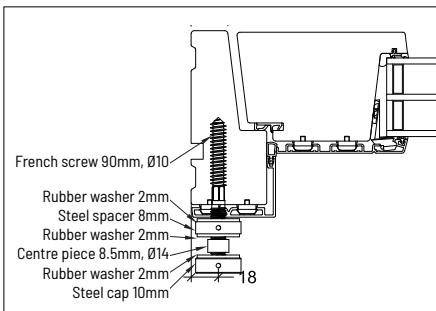
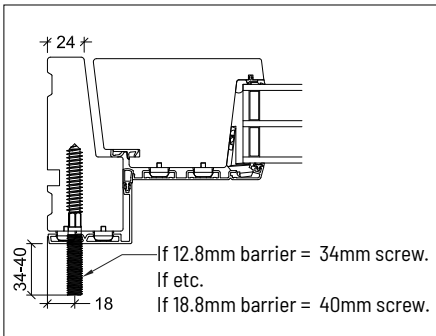
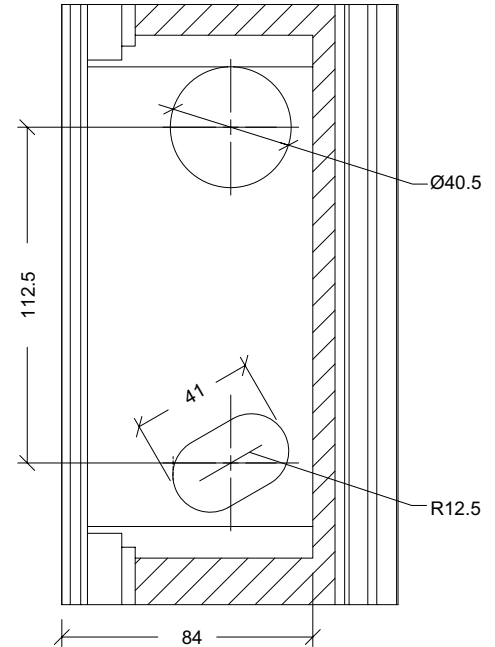
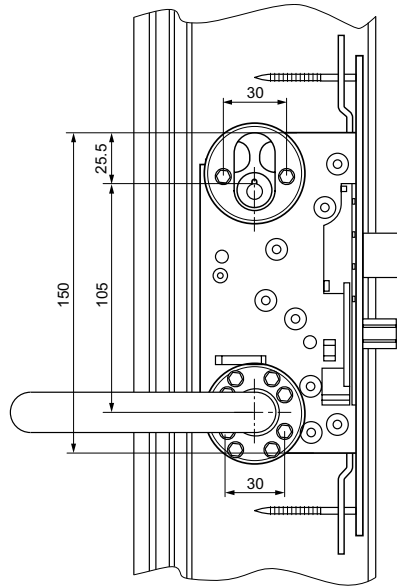

## Fitting a Juliette Balcony Barrier

- The barrier fitting is attached to the door.
- Apply joint filler in the factory predrilled screw hole before mounting the screw.
- Only screw in as deep as instructed, so that you do not damage the inside of the frame. How far in depends on the thickness of the barrier, which can be 12.8mm-18.8mm thick. Consult drawing how far the screw must protrude (34-40mm).
- Screw the steel spacer as close to the alu-clad as possible.
- Mount the barrier, cf. drawing.
- Screw the steel cap onto the screw. Ensure full engagement!
- NOTE: Screw the steel spacer outward so it tightens to the barrier. It is okay if there is a gap between the door and the inner bolt.
- NOTE: Barriers are not supplied by VELFAC.

## VELFAC Ribo Sliding Door, Installation Tips, 1/3

### General Installation Principles

- When installing a Ribo Sliding Door it is imperative the threshold is fully supported across its full width and full length.
- Externally where the structure is not a preformed cast structure i.e. exposed brick in order to achieve an aesthetically acceptable detail we would recommend the use of a folded aluminium profile.
- The aluminium profile must have a fall to aid displacement of water and prevent water pooling.
- The aluminium profile should be fully bedded / bonded to the structure using Illbruck SP 350.
- The aluminium profile should be packed level across the full length of the opening to + / - 1mm while still retaining the required tolerances at the head and sill zones.
- A fillet of Illbruck FS 125 is required atop the aluminium profile in a position that will allow the door threshold to be fully sealed.

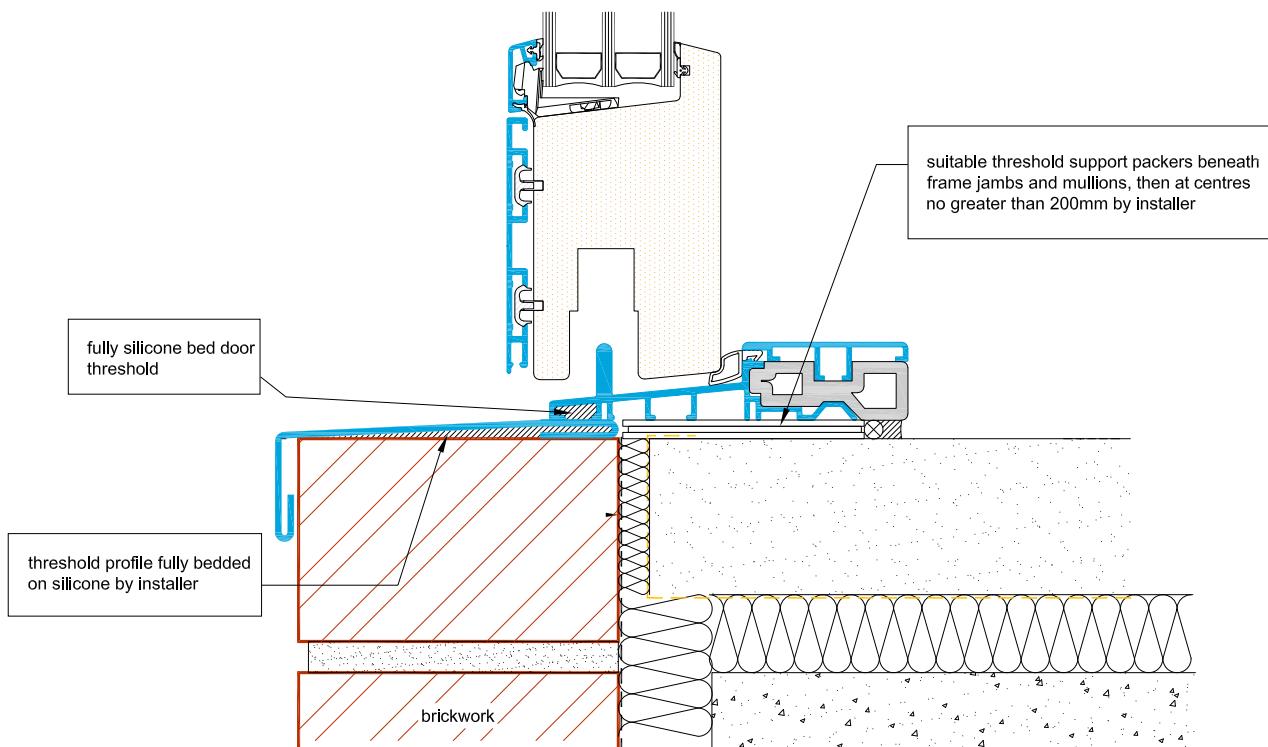

Indicative fixing arrangement for VELFAC Ribo sliding doors

VELFAC Ribo Sliding Door, Installation Tips, 2/3

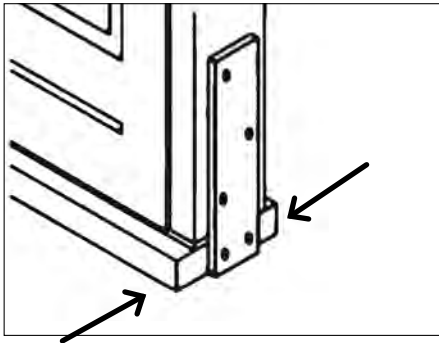

**Distribution.** To distribute a sliding door element care must be taken to ensure that when lifting the load is taken through the mullion sections. No pressure should be applied to the underside of the aluminium threshold.

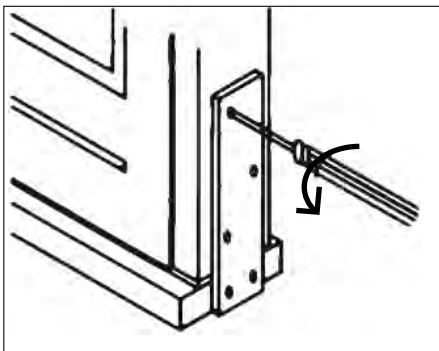

**Dismount the transport packer** under the threshold of the sliding door. It is fixed with fittings on the side.

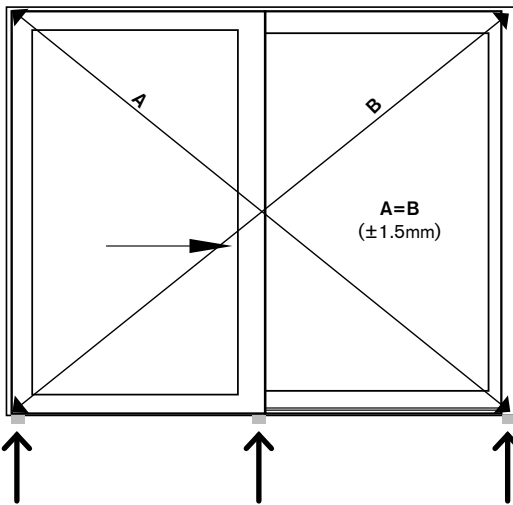

**Installation.** Prepare three supports in the structural opening and ensure they are fully supported by load bearing structure or a steel plate in the structural opening - they have to be level and aligned - one under each jamb and one under the mullion. Then, lift the door onto the three prepared supports.

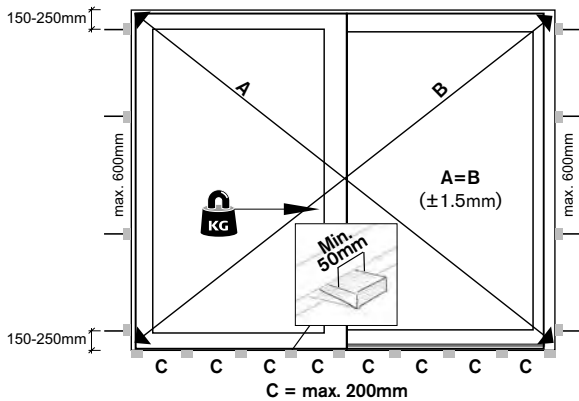

**Support** the threshold and jambs as per diagram. Install the threshold completely level and according to tolerances (+1.5mm) in order for the sliding door to glide smoothly.

## VELFAC Ribo Sliding Door, Installation Tips, 3/3

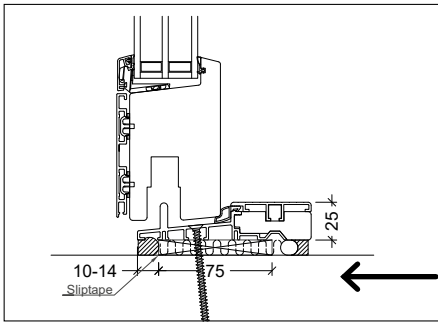

The support of the threshold ensures the stability of the guide rail. The support should therefore cover the entire width of the threshold, leaving just 10mm on both sides for sealing.

Use anti-slip tape on the external side of the support.

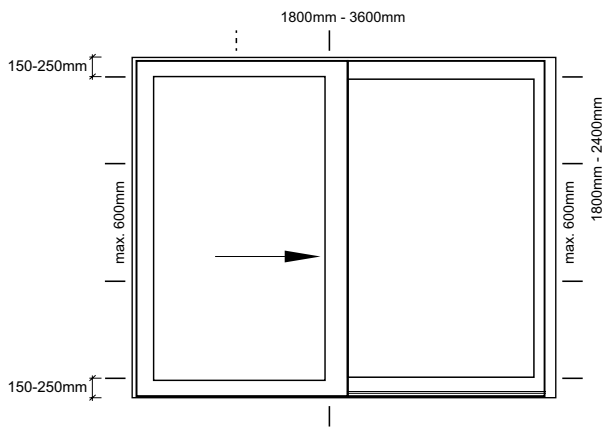

**Fixing.** Minimum three fixing points in the jambs. Drill holes through the external aluminum cladding to fix through. Cover caps are included.

Open the door and fix through the threshold at the mullion, adding two variable fixings through the head to allow for deflection under variable loads - no support between the upper frame and the structure!

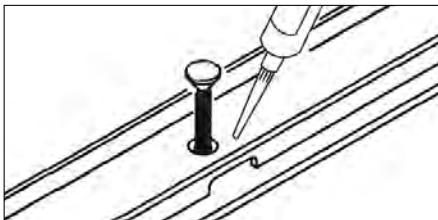

Fill the screw hole of the threshold screw in the aluminum threshold with Illbruck FS 125.

## VELFAC Ribo Windows + Casement Door, Installation Tips

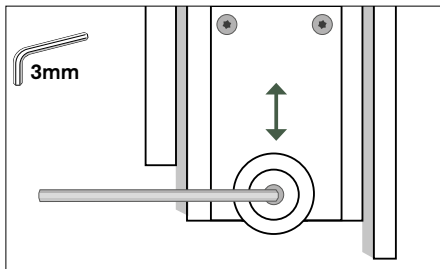

### All sidehung windows and casement doors

**The sash lift pulley wheel.** To support the window post install and assist in functionality there is a sash lift pulley wheel that can be adjusted up or down using a 3mm hex key.

To activate the sash should be opened, the exposed screw should be loosened so the wheel drops and becomes visible. Check to ensure the wheel is supporting the sash when in the closed position. The screw should then be tightened and the sash closed.

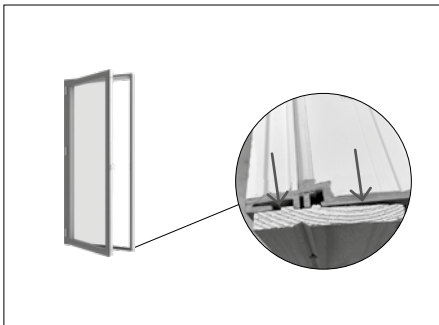

### Casement door

**Prior to installation.** At point of manufacture a timber transit packer (A) is placed under the threshold to assist support during transit. Prior to installation this should be removed. Pack and insulate the door instead to avoid rot.



## VELFAC Ribo Acoustic Trickle Vent (in Packer)



VELFAC acoustic vents are delivered separately for on site installation. Please follow these instructions for installation detailed below in order to install the vents, and the complete unit correctly.

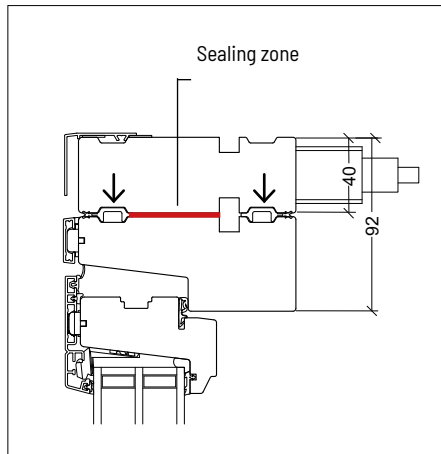

1. The acoustic vent packer should be exactly the same length as the window element.
2. On the top of the window there are two grooves within the timber section, apply an Illbruck FS 125 silicone bead between them to the entire length of the frame.
3. Sit the vent on top of the window ensuring that the coupling gaskets sit within the grooves to ensure full engagement.

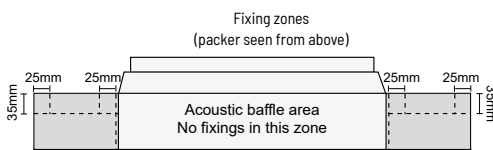

#### 4. Apply fixings as per the detail:

- All fixings should sit on a line 35mm in from the back of the trickle vent packer with the first fixing positioned 25mm in from the end.
- A second fixing should be placed on the same line 25mm in from the edge of the trickle vent hood.
- Intermediate fixings can then be placed if required at centres no greater than 450 mm.
- Screw size required is 6mm x 65mm, bright zinc plated (wood screw).
- Fixings **MUST** not be placed in the baffle zone area.

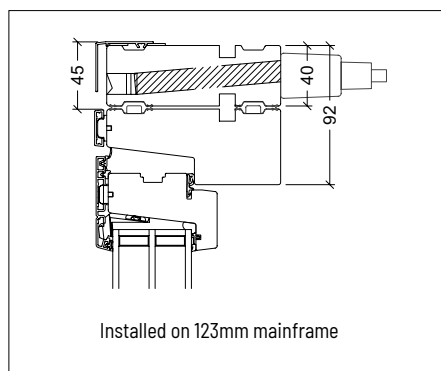
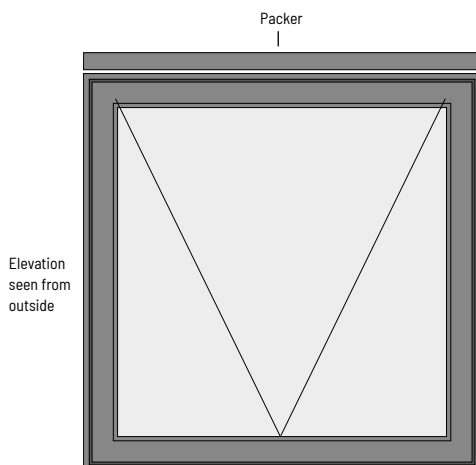

# VELFAC Aluminium Inward/Outward Opening Door, Installation Tips

## General Installation Principles

- When installing a VELFAC Aluminium Door it is imperative the threshold is fully supported across its full width and full length.
- Externally where the structure is not a preformed cast structure i.e. exposed brick in order to achieve an aesthetically acceptable detail we would recommend the use of a folded aluminium profile.
- The aluminium profile must have a fall to aid displacement of water and prevent water pooling.
- The aluminium profile should be fully bedded / bonded to the structure using Illbruck SP 350.
- The aluminium profile should be packed level across the full length of the opening to + / - 1mm while still retaining the required tolerances at the head and cill zones.
- A fillet of Illbruck FS 125 is required atop the aluminium profile in a position that will allow the door threshold to be fully sealed.

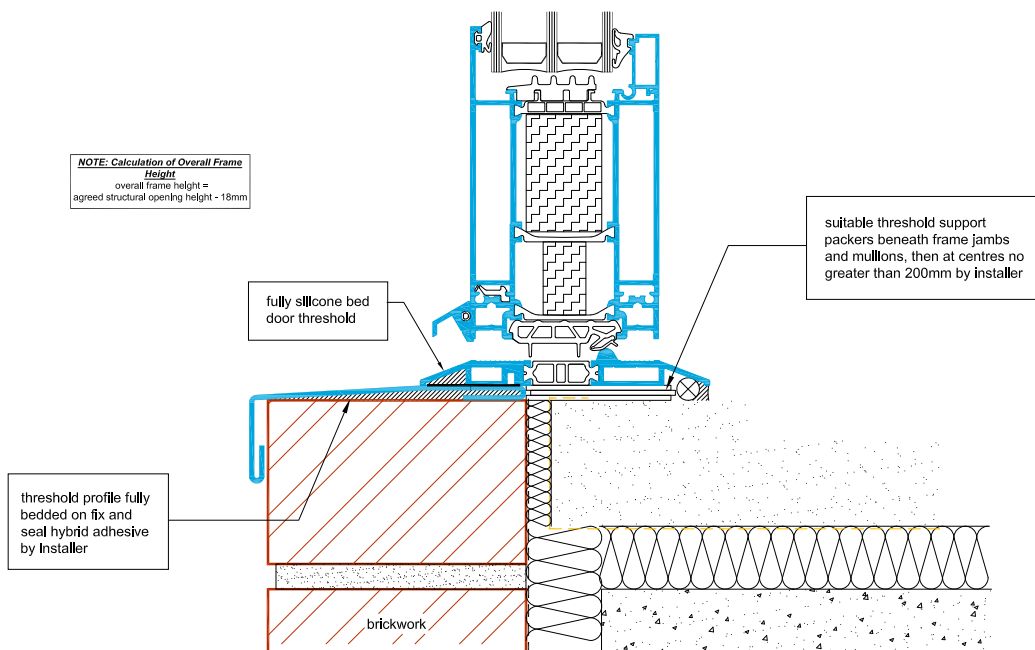

Indicative fixing arrangement for VELFAC Aluminium doors

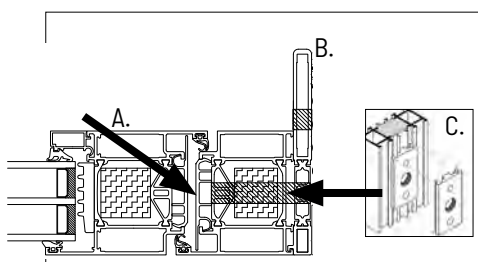

**Remove cover cap before installation:** Use a flat-head screwdriver to tilt off the cover plate of the rebate (A) before fixing the element.

If the door was ordered without the VELFAC adaptor profile (B), find the door the frame reinforcement profiles (C), which are attached to door and click them in place externally on the sash prior to installation.

## VELFAC In, Inward Opening Element, Mandatory Packing Points

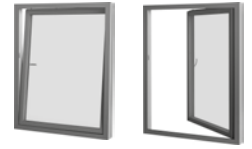

### VELFAC In Mandatory Packing Points

On a general 100 / 100 / 100 build with a standard window set back of 30mm all windows must be fully supported at each vertical load point with what is generally known as a bridging plate.

- For cavities up to 100mm, 50mm x 3mm plates are sufficient ensuring that plates are placed at each mullion or where two frames meet. For cavities larger than 100mm consider increasing to 5mm plates.
- The plate must be a minimum 3mm thick steel, preferably galvanised with the plate spanning from the internal structure to the external structure but being positioned in a manner whereby it does not impinge on the seal zone.
- Packing material should be formed from metal, plastic or nylon composite material.
- NOTE: The illustrations are in relation to single storey dead loading only, an engineer will be required to calculate the support if over 1 storey.

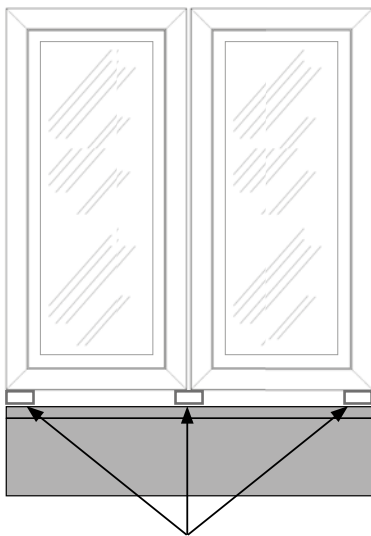

Bridging plate at each load point

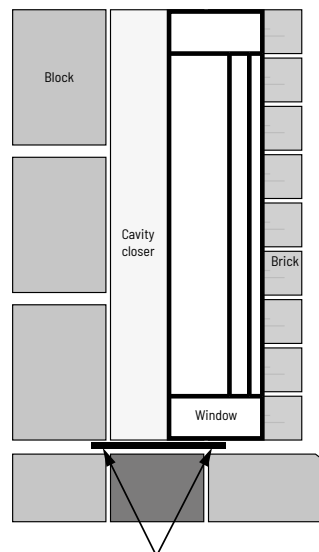

Bridging plate to span from out to in

# VELFAC In, Inward Opening Element, Installation, 1/2

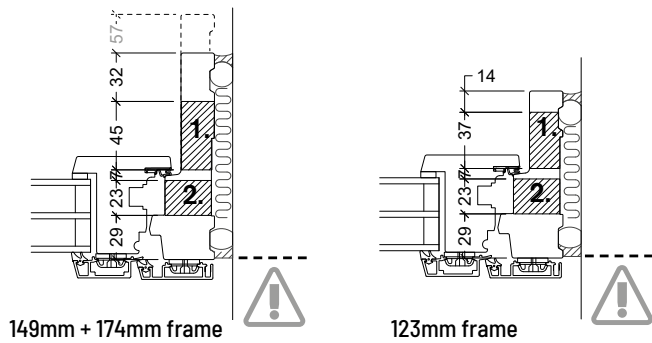

**Areas for fixing.** Choose method A or B depending on element size:

**A** ⇒ Element  $\leq 1.5\text{m}^2$  and max. width  $\leq 1200\text{mm}$ :  
Permanent fixing area 1 or 2.

**B** ⇒ Element  $> 1.5\text{m}^2$  or max. width  $> 1200\text{mm}$ :  
1. Provisional, 2. Permanent.

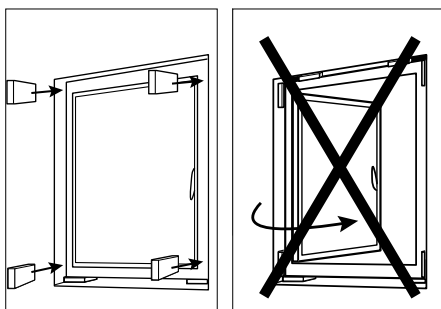

**Do not open the window / door sash:** When only provisionally fixed with packers the window may not be opened. Before final fixing the frame may need adjustment.

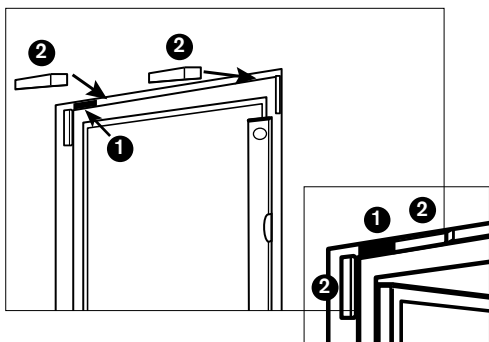

**Support packers:** Insert fixing shims / packers at the top of the frame on the hinge side close to the corner (1). Place a wedge / air wedge on the top of the frame close to the corner in readiness for fixing the frame plumb and level (2).

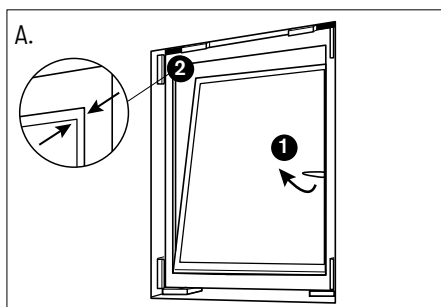

**Pre-fixing Checks (A, B and C)** important for optimal use, during which the frame must be securely held within the opening!

A. Carefully test the **tilt function** by turning the handle to the horizontal position (1). When closing the window ensure that the sash rebate initially closes against the frame at the top corner opposite the handle (2).

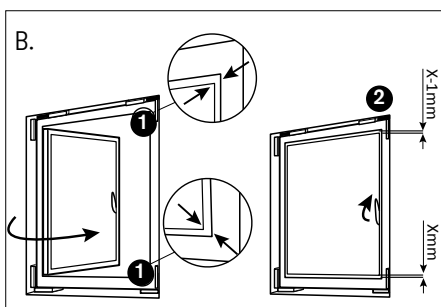

B. Carefully test the **turn function** by turning the handle to the vertical position. When closing the window ensure that the sash rebate closes against the frame at the top and bottom corner at the same time (1).

In the handle side, the gap between the sash and the frame at the top should be 1mm less than the gap between the sash and the frame at the bottom. (2).

## VELFAC In, Inward Opening Element, Installation, 2/2

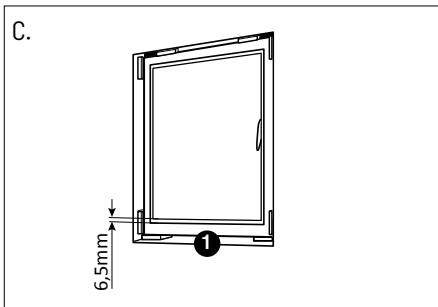

C. When the **window is closed** make sure there is a gap of at least 6.5mm between the sash and the frame at the bottom (1).

Adjust the frame if necessary and check again.

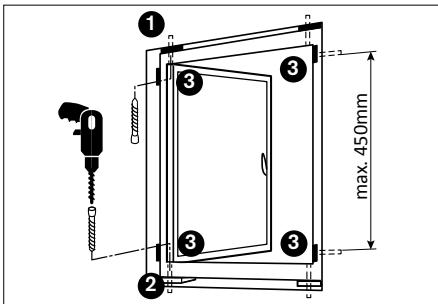

**Final fixing and packing** to prevent twist and forced entry:

- All fixing points must be adequately supported using appropriate packers.
- Thresholds must be adequately supported in the entire width (per max. 200mm).
- Install the first screw in the frame head on the hinge side as close to the jamb as possible. If this is not possible because of the brickwork, the screw must be installed in the jamb as close to the top as possible (1).
- The second screw is installed in the cill directly below the first screw (2).
- When fixing the rest of the screws, ensure that there is equal space all around the element (3).
- The hinge side should always be fixed at maximum 100mm from top and bottom of the element (4).
- The distance between fixing points may not exceed 450mm at any side of the frame (5).
- To increase burglary resistance, place an adequate packer behind each striking plate.

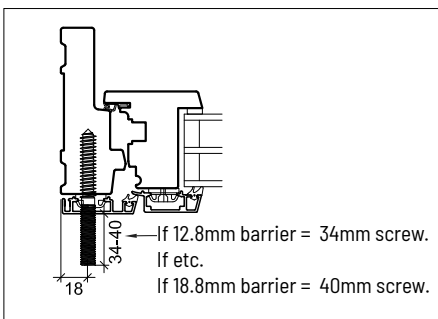
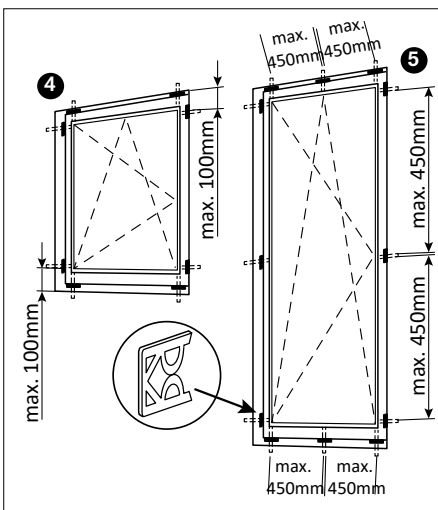

### Fitting a Juliette Balcony Barrier

- The barrier fitting is attached to the door.
- Apply joint filler in the factory predrilled screw hole before mounting the screw.
- Only screw in as deep as instructed, so that you do not damage the inside of the frame. How far in depends on the thickness of the barrier, which can be 12.8mm-18.8mm thick. Consult drawing how far the screw must protrude (34-40mm).
- Screw the steel spacer as close to the alu-clad as possible.
- Mount the barrier, cf. drawing.
- Screw the steel cap onto the screw. Ensure full engagement!
- NOTE: Screw the steel spacer outward so it tightens to the barrier. It is okay if there is a gap between the door and the inner bolt.
- NOTE: Barriers are not supplied by VELFAC.

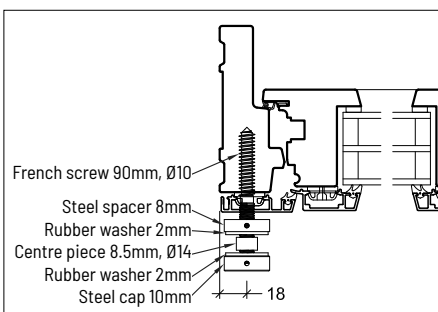

# VELFAC Fire Element, Installation



Fire element, installation precautions: Carefully follow the installation instructions shown here. You will also find them on the glazing.

Approved sealing material for VELFAC Fire elements:

- Fire rated silicone Illbruck FS703
- PU Foam Illbruck Nullifire FF197

## Mounting instructions/Montagevejledning

To ensure the products fire proofing abilities, it is important that the mounting instructions are followed.

For at sikre produktets brandtekniske egenskaber, er det vigtigt at montagevejledningen følges.

### A. Mounting/Montage

- 1 Compressed mineral wool – compressed 3 times as hard as normal.  
Sammenpresset mineraluld - sammenpresset 3 gange hårdere end normalt.
- 2 Backing rod.  
Fugebagstop.
- 3 5-20 mm mastic sealant.  
5-20 mm fuges.
- 4 Fixing zone – must be fixed per 450 mm.  
Fastgørelseszone - skal fastgøres per 450 mm

### B. Coupling to fire door/Sammenstilling til branddør

- 1 ATTENTION: Through-going silicone sealant must be applied to the fire element before coupling the two products.  
VIGTIGT: En gennemgående streng af siliconefugemasse placeres på brandelementets karm før sammenstilling.
- 2 Packer - must ensure gap of max 6 mm between the products.  
Afstandestykke som sikrer maksimalt 6 mm mellemrum.
- 3 Backing rod.  
Fugebagstop.
- 4 Mastic joint – max 6 mm wide.  
Fuge - maksimalt 6 mm bred.

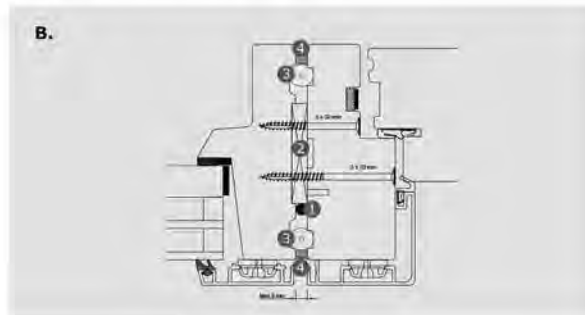
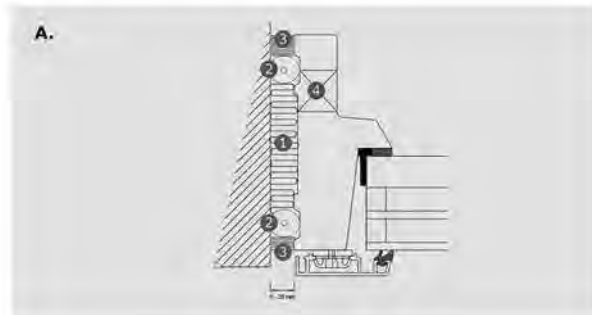

## General info about VELFAC 200 systems

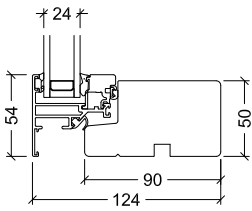

VELFAC 200 DGU

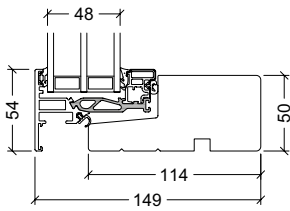

VELFAC 200 ENERGY

The VELFAC 200 system is available in double (DGU) and triple glazed (ENERGY) versions.

The guidance on the following pages is valid for both systems if nothing else is indicated.

Guidance that is different will be indicated by specifying either VELFAC 200 DGU or VELFAC 200 ENERGY.



**Adjusting the closing pressure in VELFAC 200 ENERGY**  
 Opening functions are fitted with an adjustable striking plate. Only exception is the outward opening casement door. Adjust the closing pressure by loosening the screw fittings with a torx 15 drive and tap the striking plate inwards to make the small pins in the plate break. Follow this by relocating the plate (-1mm/+2mm) and re-tightening the screws.

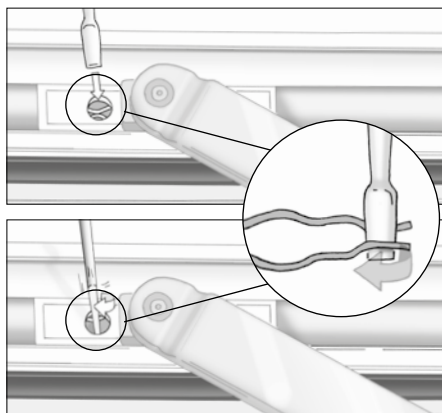

**Desashing:** Prior to demounting the aluminium sash from the timber mainframe consider the weight and ensure suitable resource is available.

Release the friction arm by placing a flat headed screwdriver within the clip and rotate 90°.

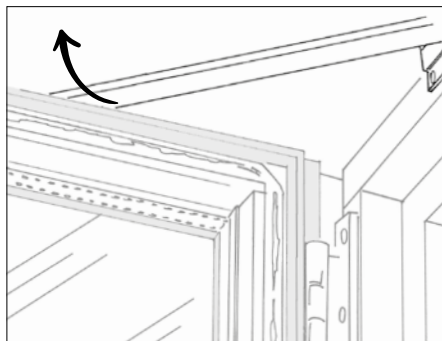

Now release the friction arm from the sash.

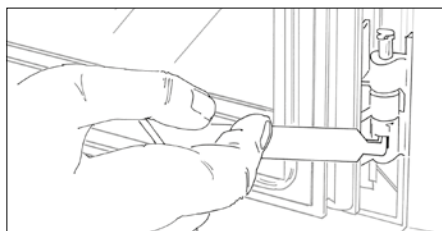

Lift the hinge pins using a VELFAC pin remover (available on request, order code 51.413).

Working from bottom hinge upwards ensuring the sash is fully supported at all times, remove all pins.

Lift off the sash.

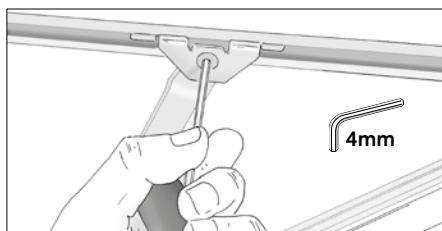
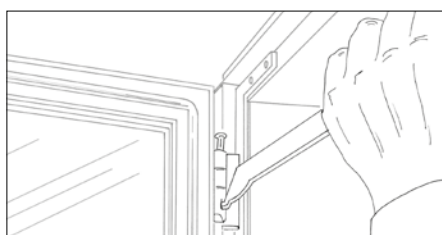

**Adjusting the friction arm:** Using a 4mm hex key loosen or tighten the screw.

Do not lubricate!

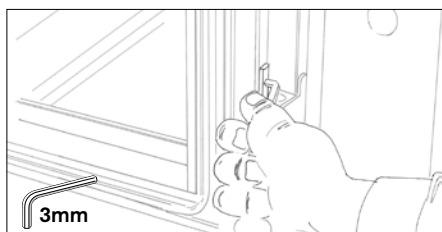

**Height adjustment:** Ensure the sash is fully supported loosen the fixing in each hinge using a 3mm hex key and adjust in the direction required ie up / down.



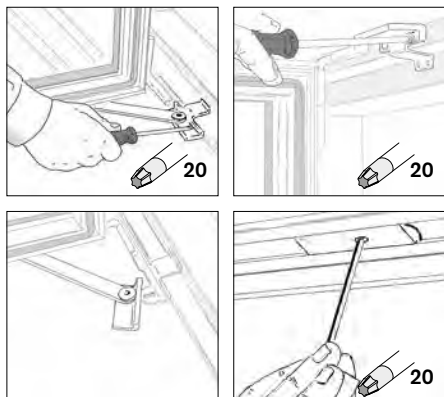

**Desashing:** Open the sash to 90°. Using a Torx 20 drive remove the fixing screw at the top and bottom part of the frame and turn it away. Using a Torx 20 drive unscrew and remove the stop blocks (if any) at the top and bottom guide rails.

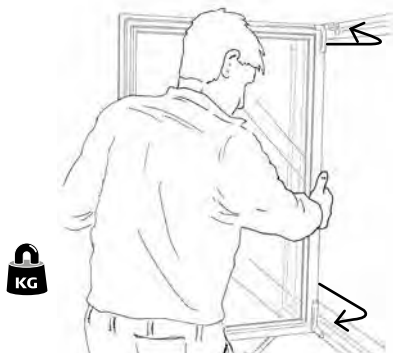

Keeping the sash vertical slide out of the guide rail.

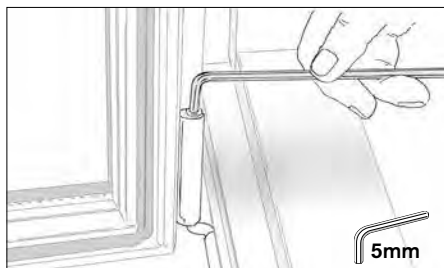

**Height adjustment:** Using a 5mm hex key turn the screw in the bottom hinge to move the sash up or down as required.

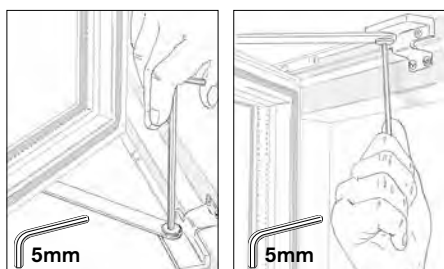

**Adjusting side to side:** Open the sash. Using a 5mm hex key move the sash by turning the screw in the guide arm at the top and bottom of the frame.

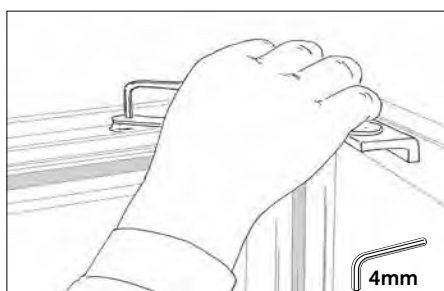

**Adjusting the friction arm:** Using a 4mm hex key loosen or tighten the screw at the top and bottom of the window sash.

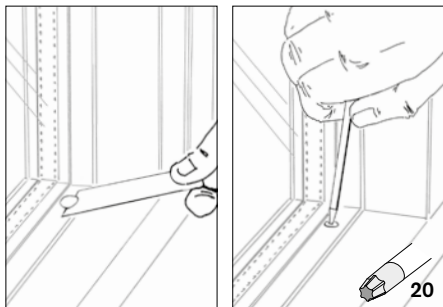
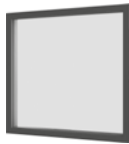

**Desashing:** Remove the internal screw cover caps located at each bottom corner of the sash with a flat bladed tool. Using a Torx 20 drive remove the factory applied screws.

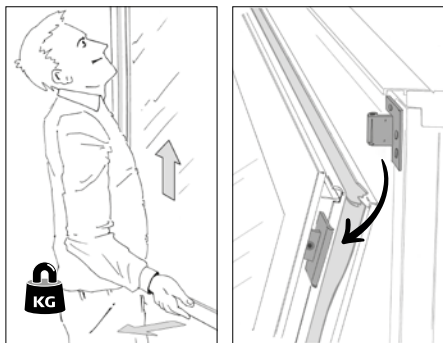

Lift the sash slightly (5mm or 6mm), pull it outwards (20mm - 30mm) and lower it. We recommend the use of glass suckers for this operation.



**Heavy units.** Where units are considered too heavy to manually handle appropriate lifting equipment should be considered.

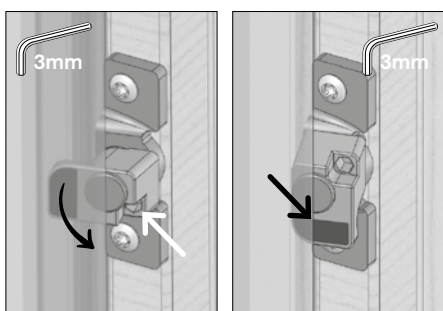

**Units greater than 1200mm in height** have additional factory applied hardware that must be disengaged. These are known as tumbler fittings.

*To release the sash:* Using a 3mm hex key or the VELFAC tool supplied (item no. 62.1167) with the fixed casement from outside press the sash against the frame, while turning the fitting 90° anti-clockwise to release the sash.

*To re-engage the sash from the outside:* Press the sash against the frame and turn the fitting 90° clockwise to re-engage the sash.

**NOTE:** This view of the retainer brackets shows them on the right side of a unit seen from the outside. On the left side, they are fitted upside down, so the latch must be turned upwards.

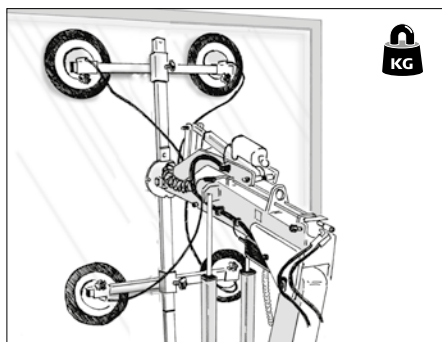
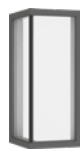

**Handling.** When using suction cups, it is recommended to lift the corner window with suction on both panes at the same time.

If a lifting point can only be gained on one leaf this must be applied to the largest pane

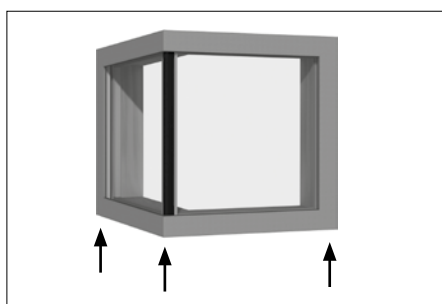

**Installation.**

- Support for dead load under both jambs, as well as under the external corner (where the panes meet).
- Fix according to the same principles as other VELFAC 200 windows.
- Install with the dripcap upwards, to protect against water penetration and so eventual moisture can escape through the drainage holes at the bottom of the windows.

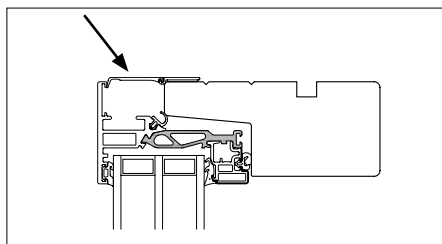

Corner windows may not be stacked, unless the dead load of the top unit:

- is transferred to built-in bracing in the coupling (external engineering calculation required).
- is not transferred to the bottom unit.



**Desashing.** Locate the long VELFAC Allan key (item no. 62.1167) on the glazing of the sliding door or a fixed sash within the delivery.

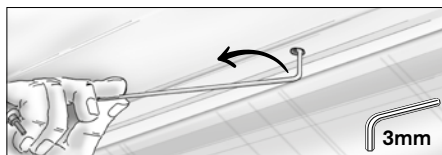

Remove the internal cover cap with a flat bladed tool. From the outside press sash and frame together to reduce pressure. Using the 3mm hex key supplied rotate hex key fitting clockwise through 90° to the left.

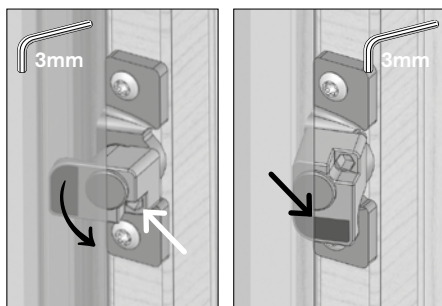

Using a 3mm hex key now loosen the tumbler fittings located on each jamb:

Press sash and frame together, firmly place the Allen key in the fitting and free the sash by turning each tumbler fitting 90° anticlockwise.

This view of the retainer brackets shows them on the right side of a unit seen from the outside. On the left side, they are fitted upside down, so the latch must be turned upwards (anticlockwise).

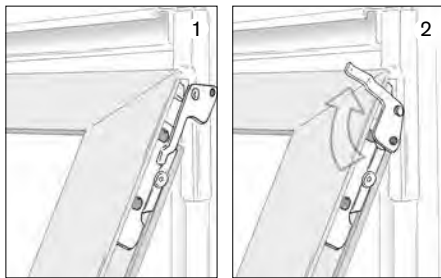

**Desashing.** Open the sash to its maximum. Sashes over 45kgs are fitted with additional hardware (security catches), which must be released (1+2).

Using a 3mm hex key loosen the stops beneath the friction arms, move them downwards and tighten the screws (3).

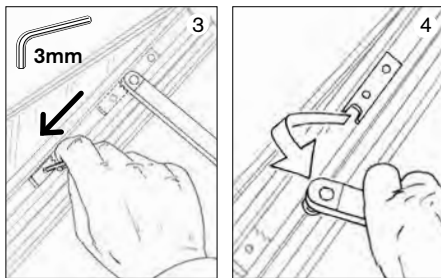

Release the friction arms from the sash (4).

**N.B. Once the friction arms have been released the sash may disengage!**

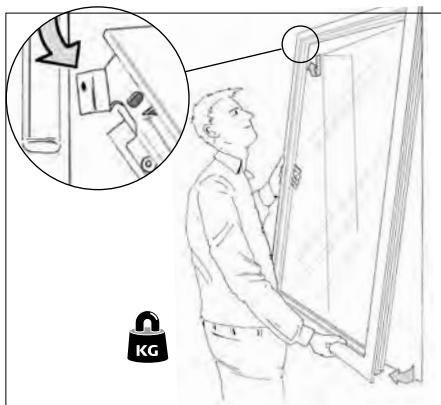

Open the sash to approximately 45°, then tilt it out of the guide rail.

**Re-fit the sash:** Make sure the top guide (the white block) points downwards, when entering the guide rail.

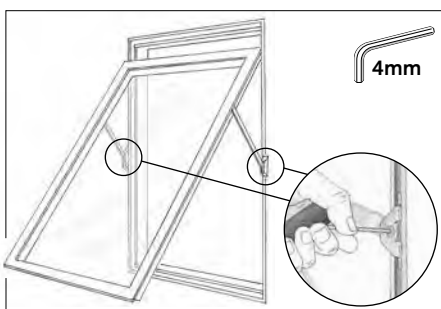

**Adjusting the friction arm.** Using a 4mm hex key adjust the friction arm on both sides to ensure smooth operation. Do not lubricate!

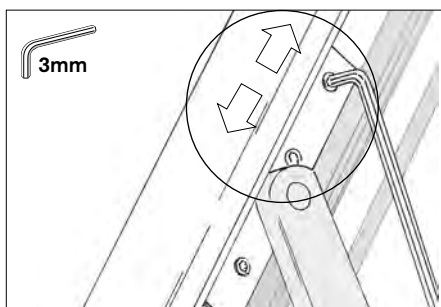

**TIP:** Sashes can be adjusted / aligned using a 3mm hex key to loose the fitting in either side and move the friction arm slightly up or down. Sashes must be fully supported while adjusting.

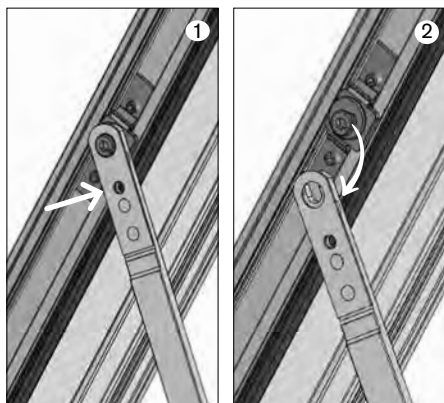

**Desashing.** Open the sash to maximum position.

While the sash is fully supported:

1. dismantle the friction arms using a flat head screwdriver to unclick the friction arm
  2. first to one side followed by the opposite side.
- The sash now hangs in the top brackets.

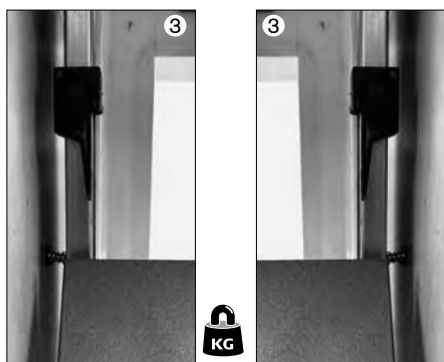

3. Fit a VELFAC sash derailer on both sides of the sash bracket. Support the sash and move it upwards - the movement will derail the frame. **N.B.** The sash is now detached.

VELFAC derailleurs have item numbers: 50.0651N (left) and 50.0652N (right).

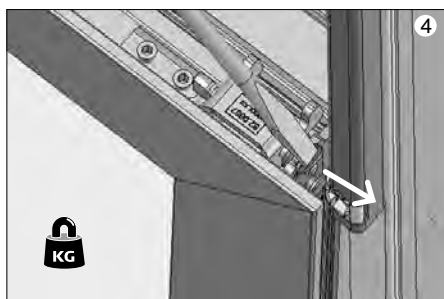

If sash derailleurs (3) are not available the following steps can be taken:

4. At the sash top brackets in both sides: press aside the spring lock, while lifting the sash up and out of the bracket. **N.B.** The sash is now detached.

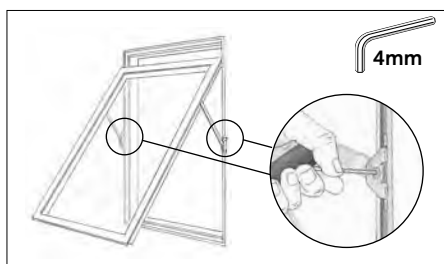

**Adjusting the friction arm.** Using a 4mm hex key adjust the friction arm on both sides to ensure smooth operation. Do not lubricate!

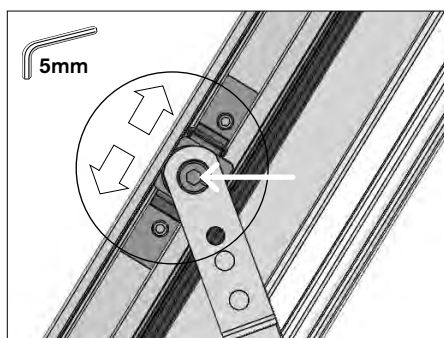

**Height adjusting:** Using a 5mm hex key turn the screw to adjust the sash up and down as required (90° = 2mm).



# VELFAC 200 ENERGY / Tophung reversible 1/2

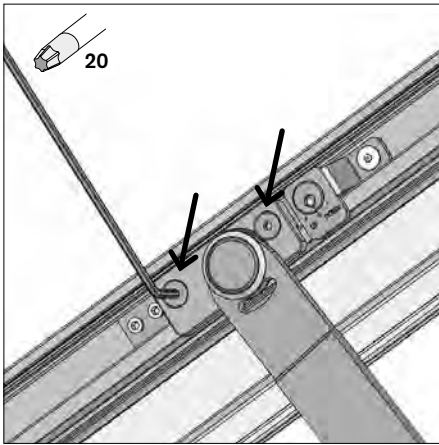

**Desashing:** Using a Torx 20 drive loosen completely loosen (but not remove) the screws that attach one friction arm to the sash. Then release the arm from the sash. Repeat with other friction arm. The sash load is now taken by the top brackets and must be supported.

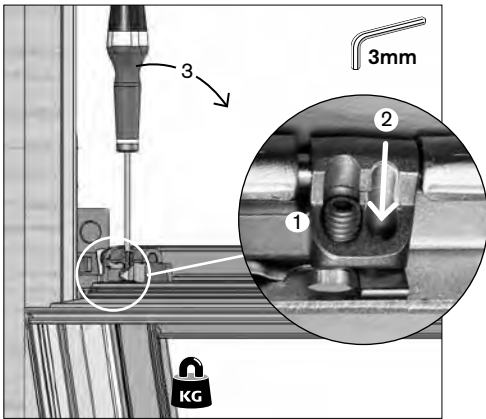

1. Release the pivot locks in the top brackets by first loosening the grub screw so it is level with the underside of the bracket.
2. Follow this by inserting a 3mm hex key into the hole adjacent to the grub screw onto the lock plate in order to release the bracket.
3. To release the bracket apply pressure downwards and then push the hex key forwards simultaneously, repeat on opposite side.



The sash is now disengaged and may be put down.

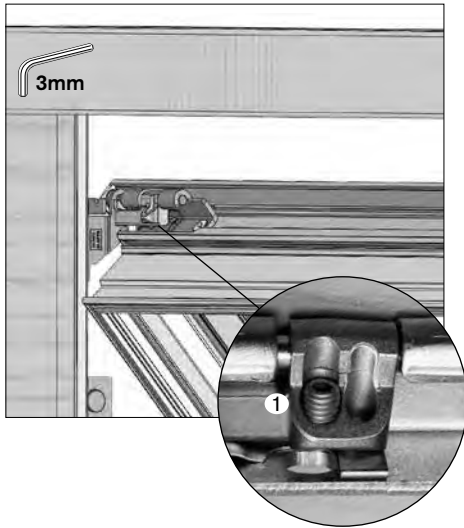

**Re-engaging the sash:** Lift up the sash and rotate the pivot lock towards the top bracket by hand, until a snap sound is heard.

Follow this by tightening the grub screw (1), so that the sash is secure.

Now re-engage the friction arms and tighten the their fixings.

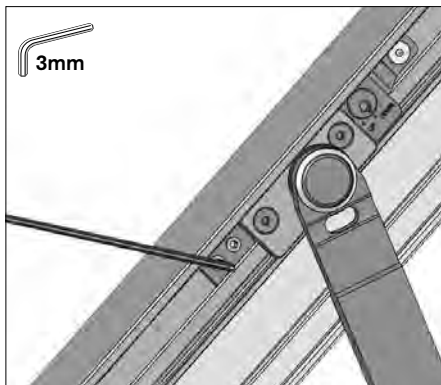

**Adjustment and alignment:**

1. Using a 3mm hex key first loosen the 2 locking screws on the sash beneath the friction arm.

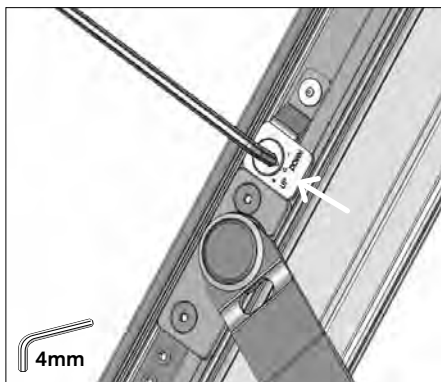

2. Using a 4mm hex key adjust the sash either up or down by turning the outer rivet above the friction arm either clockwise or anti-clockwise.

There are marks on the screws indicating direction.

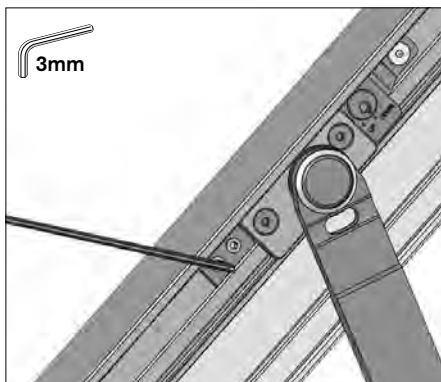

3. Using a 3mm hex key tighten the 2 locking screws again.

## VELFAC 200 / Tophung window

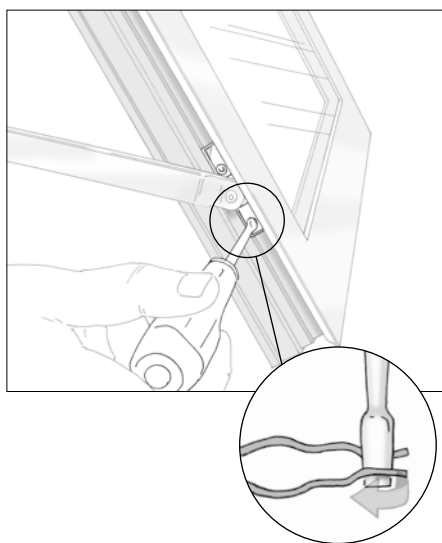
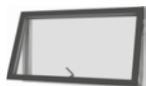

**Desashing:** Release the arm by placing a flat bladed screwdriver within the clip and turn the screw driver 90°. Now release the arm from the sash.

**N.B.** Once the arms have been released, the sash may disengage!



Open the window to a horizontal position and lift it off.

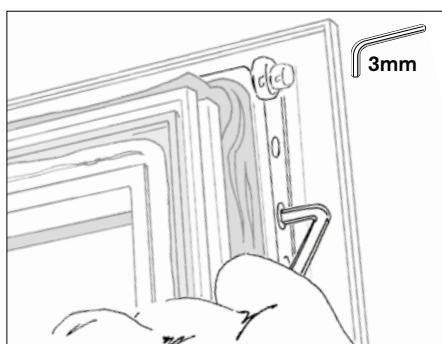

**Height adjustment.** Using a 3mm hex key loosen the fixings and move the sash fittings up or down on both sides.

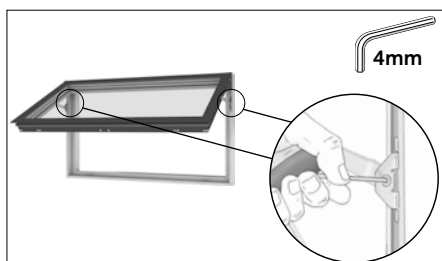

**Adjust the friction arms.** Using a 4mm hex key adjust the friction arms on both sides to allow the sash to function correctly. Do not lubricate!





**Desashing:** Open the window and detach the motor chain.

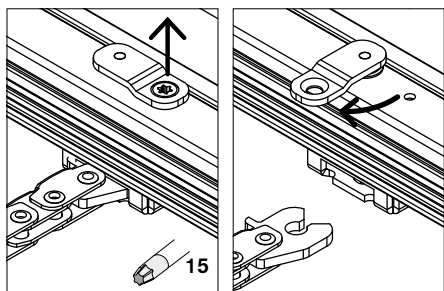

**Release the chain from the sash:** Never release the chain while the window is closed. Wire it out slightly, then remove the screw and turn the bracket 90°. Pull the sash out of the chain.



[See video](#)

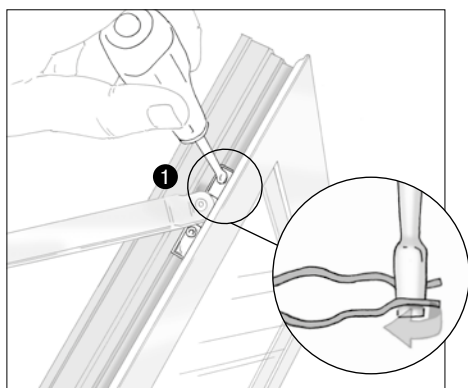

1. Release the arm by placing a flat bladed tool within the clip and rotate 90°. Now release the arm from the sash.

**N.B.** Once the arms have been released, the sash may disengage!

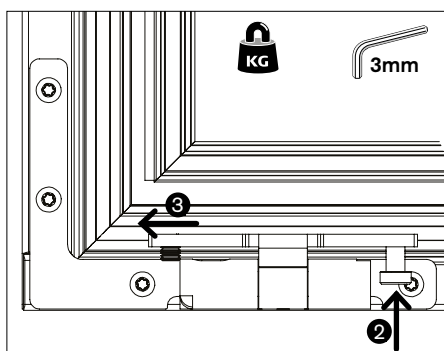

2. Using a 3mm hex key remove the screw that locks the hinge pins.

3. Push out the hinge pins using a VELFAC pin remover (available on request, order code 51.413).

Be careful to hold the sash, remove both pins and lift off the sash.

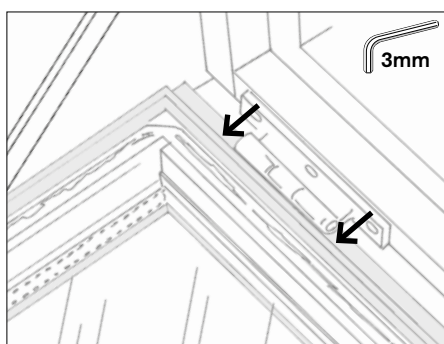
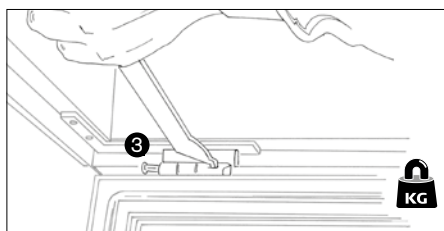

**Sideways adjustment.** Using a 3mm hex key loosen the hinge fittings in the sash groove at both ends of the sash. Then move the sash sideways to adjust and re-tighten the screws.



**Handle operated brake or friction arm?** VELFAC 200 casement doors are available in two versions. The triple glazed can be fitted with either handle operated brake (A) or friction arm (B). The double glazed variant is only supplied with a friction arm (B).

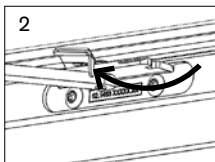
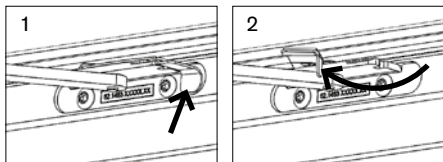

**(A) Desashing the door unit with handle operated brake:**  
Release the brake arm from the frame by turning the locking bracket (1 + 2).

The brake arm can now be released from the frame (3).

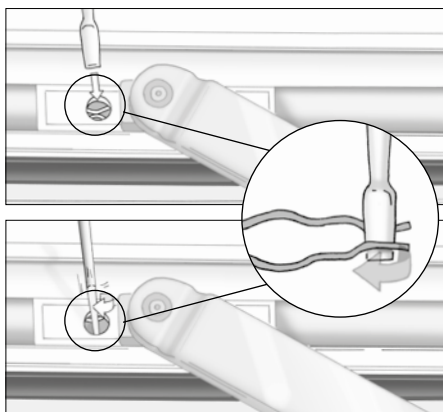
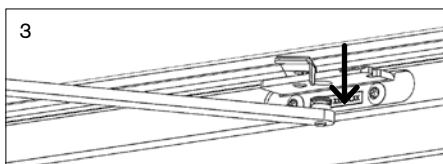

**(B) Desashing the door unit with friction arm:**  
Release the friction arm by placing a flat headed screwdriver within the clip and rotate 90°.

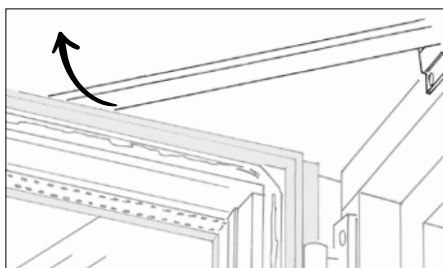

(A+B) Now release the friction arm from the sash.



(C) Should the above operations not be possible due to access restrictions an alternative would be to free the friction arm on the mainframe using a torx 20 drive. Any surface damage should be repaired prior to re-engagement.

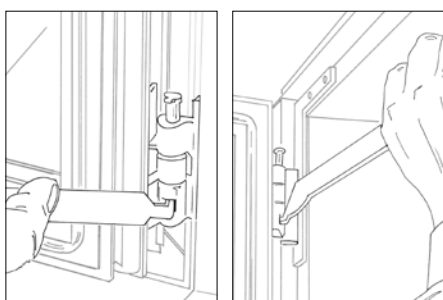

(A+B+C) Ensuring that the sash is fully supported and starting at the bottom, lift the hinge pins using a VELFAC pin remover (available on request, order code 51.413). Be careful to hold the sash, and remove both pins. Lift off the sash.



**Threshold type?** VELFAC 200 casement doors are available with three different threshold types and thus suitable for all sorts of installation. Adjustment however is performed differently depending on threshold type. Please see below.

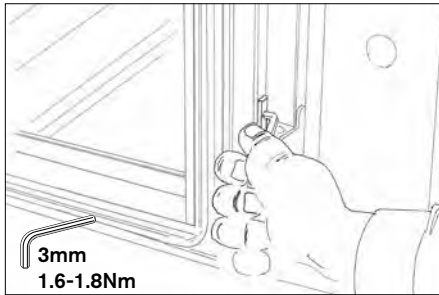

**Height adjustment, door with 15mm/52mm threshold:**

Fully support the sash.

Using a 3mm hex key loosen the screws in the sash next to all hinges and move the sash up or down as required.

Tighten the screws again.

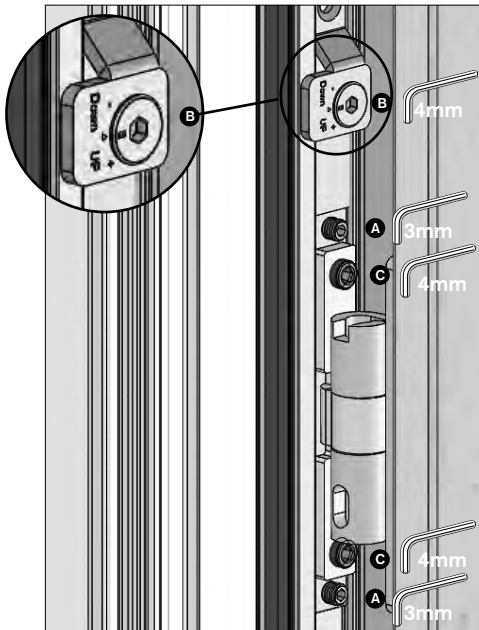

**Height / side to side adjustment, door with 24mm threshold\*:**

Only applicable for tripled-glazed casement doors.

Height: Using a 3mm hex key loosen the screws (A) in all hinges. Support the sash and using a 4mm hex key turn the adjusting screws (B) in the desired direction (UP/DOWN).

Using a 3mm hex key tighten the hinge screws (A) again (with 1.6-1.8Nm).

Side to side: Using a stub 4mm hex key turn the screws (C) max. ¼ turn at a time. Tighten both screws equally.

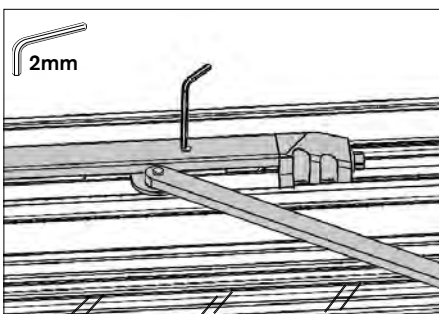

**Adjusting the handle operated brake (if any):**

Only applicable for tripled-glazed casement doors.

Open the casement door completely. Align the screw head with the hole in the cover rail at the top of the sash. Insert the 2mm hex key into the screw head, then turn slightly clockwise to tighten the brake. 10-20° will usually be enough.

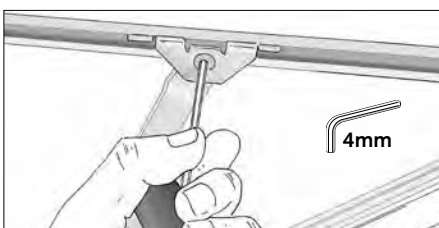

**Adjusting the friction arm (if any):**

Loosen or tighten the screw using a 4mm hex key.

Do not lubricate!

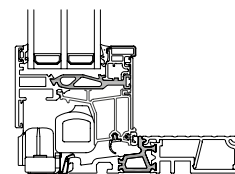

[See video 7:56](#)



**Desashing the fixed unit.** Secure the sash of the fixed unit with an appropriate lifting gear.

Remove the internal cover cap in the top frame using the VELFAC Allen key provided to rotate the tumbler fixing through 90°.

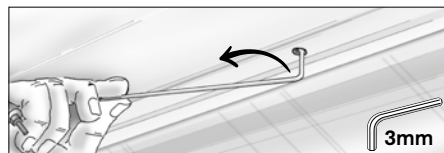

VELFAC Allan key, item no. 62.1167.

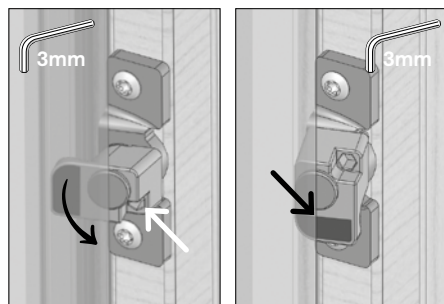

Apply the same process to the tumbler fixings located to the frame perimeter.

NB. The illustration of the tumbler fixings shows them on the right side of an unit seen from the outside. On the left side, they are fitted upside down, so the latch must be turned upwards (anticlockwise).

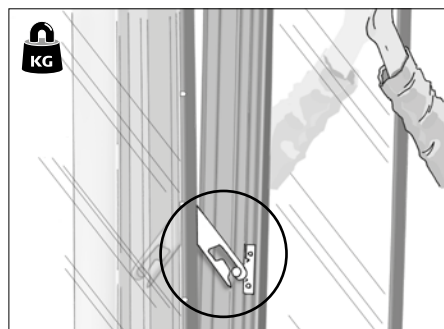

Tilt the frame out at the top. Use the safety catches to hold it at a 25-30° angle.

Ensuring at all times that the sash is safely retained, push the sash inwards releasing the pressure on the safety catches. Then release the safety catch on both sides of the sash by pushing it upwards.

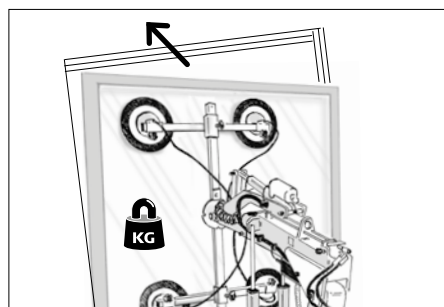

To complete the desashing process gently lift the sash and ...

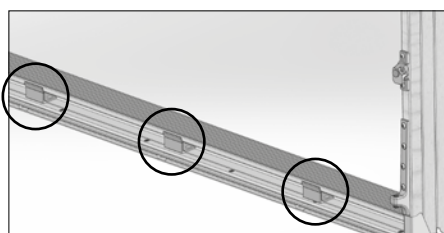

... remove it from the brackets on the threshold.



Store the sash in an upright position leaning on the aluminium sash, packed off of finished floor. Prevent any weight being applied to the plastic profiles that form part of the sash.

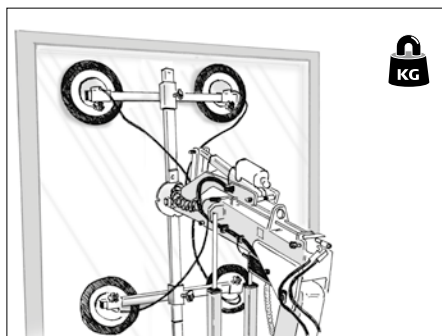
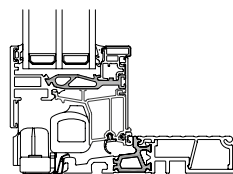

**Resashing the fixed unit.**

Use suitable lifting gear and position the fixed sash at the bottom:

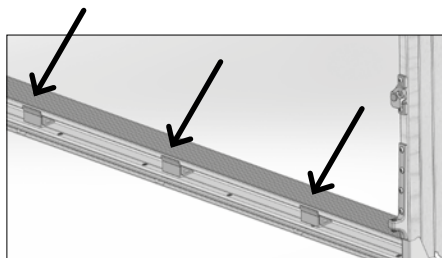

- Gently lift the sash over the running track and lower it down carefully.
- The retainer brackets in the threshold should engage with the holes in the bottom of the sash..

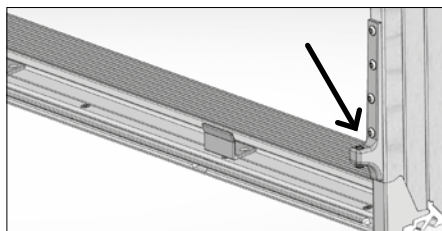

- The sash should rest on the support arms at the bottom of the frame on both sides.

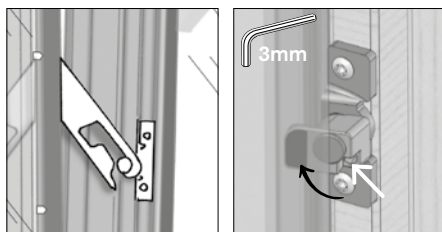

- Follow this by reinstating the safety catches on both sides so the sash cannot fall out.
- Press frame and sash together and turn the tumbler fixings located at the frame perimeter.

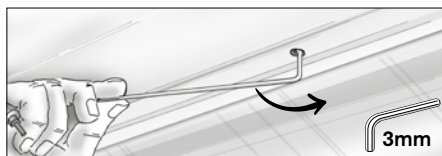

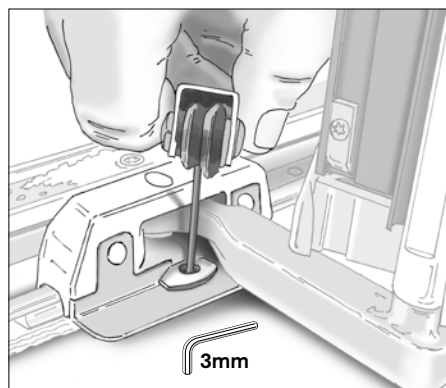

**Desashing the opening unit.** Open the handles of the running sash. Pull the sash slightly outwards and slide it to the side so that the sliding door is slightly open.

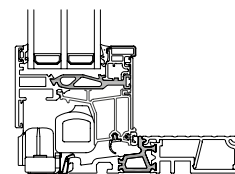

[See video 9:08](#)

Using a 3mm hex key remove the safety catch in the running track.

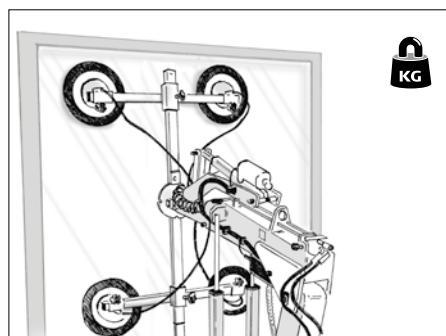

Secure the sash of the opening unit with an appropriate lifting gear.

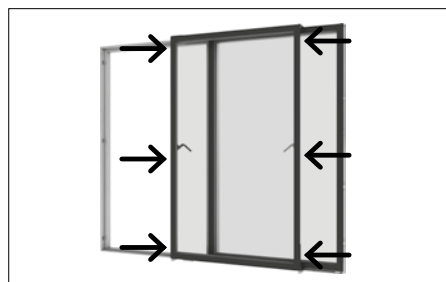

Now free the top slide arms. There are 3 grub screws in the guide rod in both ends of the sash. These secure the top slide arms.

To release the slide arms complete the steps below to both sides of the unit using a 3mm hex key (no. 1-6):

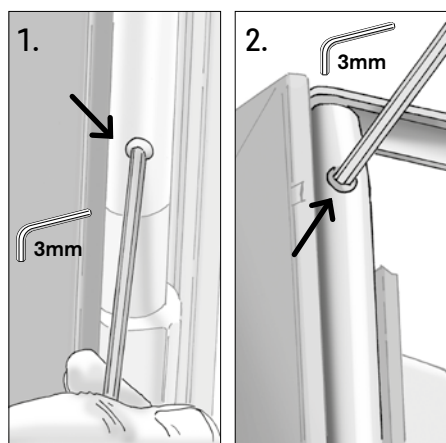

1. To temporary secure the wheeled truck, tighten the middle screw so it is level with the guide rod.

2. Loosen but do not remove the screw located at the top.

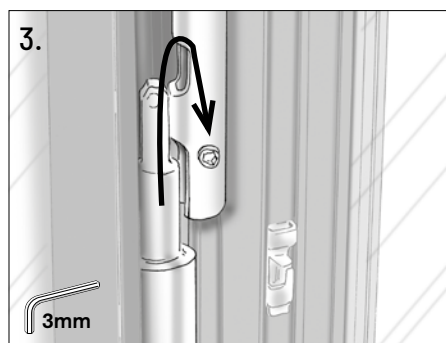

3. Loosen but do not remove the screw located at the bottom, this will allow the guide rod to be lifted out and repositioned to the side.

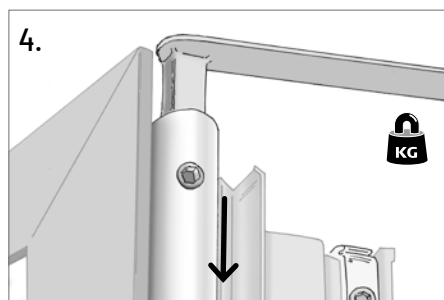
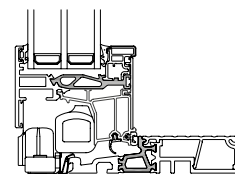

4. Lower the guide rod to release the top slide arm. The frame and sash of the opening unit have now been separated and the frame is ready to be installed (NOTE: section 5-6).

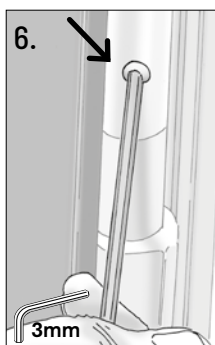

5. Lift the guide rod at both ends of the primary sash into place and re-tighten the tailstock screws at the bottom and top.

6. Finally, loosen the tailstock screw in the middle.



7. To complete the desashing process gently lift the sash and remove it from the threshold.

Store the sash in an upright position leaning on the aluminium sash, packed off of finished floor. Prevent any weight being applied to the plastic profiles that form part of the sash.

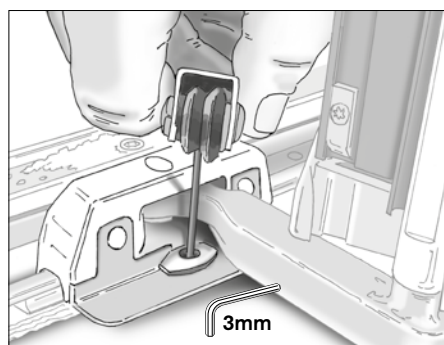

**Desashing the secondary opening unit in 2-leaf doors.**

Open the handle and release the flush bolt in the mullion of the secondary sash. Pull the sash slightly outwards and slide it to the side so that the secondary door is slightly open.

Using a 3mm hex key remove the safety catch in the running track.



Disengagement of the top slides in the secondary sash should be carried out in the same manner as for the primary sash (sections 1-6).

However, in order to access the tailstock screws in the guide rod of the French casement mullion, you must first remove the locking plate in front of the guide rod using a torx 25 drive. The mullion can then be turned around completely making the tailstock screws accessible.

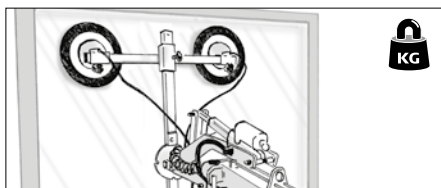
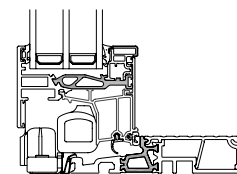

**Resashing the opening unit.**

Now lift the opening glazed sash and reinstate following the below guidance.



Carefully place the sash next to the frame so that it rests on the bracket arms of the carriage.

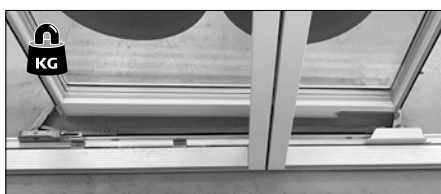

Lift the sash into place on the threshold, with one carriage positioned either side of the mullion.



Check that both carriages are positioned correctly on the running track.

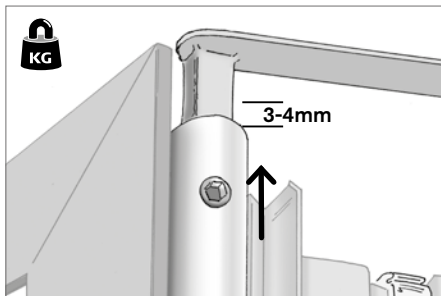

Follow this by reengaging the top slider arm in the guide rod at both ends (sections 1-6 in reverse order).

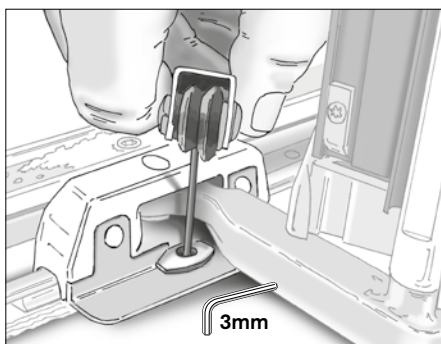

Finish by reinstating the safety catch in the running track.



**The following applies to 2-leaf sliding doors:**

Start by reinstating the secondary sash, followed by the primary.

On the side of the French casement mullion: turn the mullion into place and reinstate the locking plate using a torx 25 drive.



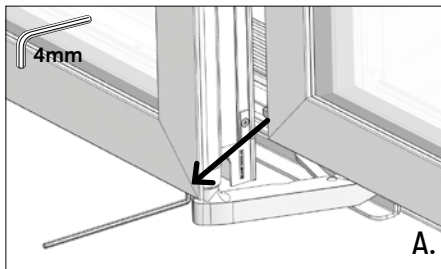
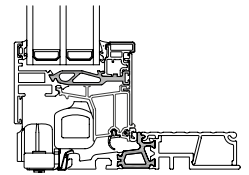

**Height adjustment.** If the sashes do not align and the frame is installed within the tolerances, one or both sashes should be height adjusted.

A. At the opening sash the adjustment screw can be located on the underside of the truck on both sides of the sash.

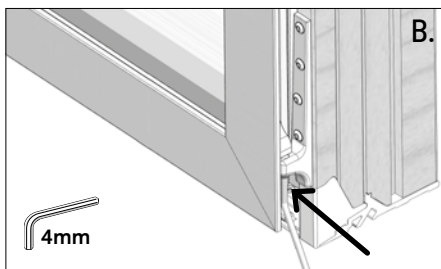

B. At the fixed sash the adjustment screw can be located on the underside of the corner bearing on both sides of the sash.

A+B. Remove the weight of the sash from the screw by lifting slightly, and using a 4mm hex key turn anticlockwise to lift the sash upwards.

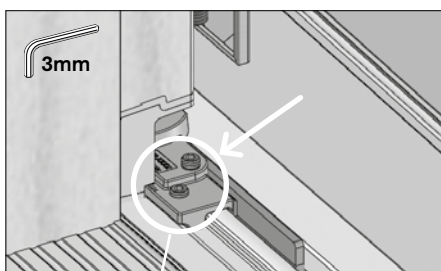

**Lateral adjustment of the sliding sash** must be carried out if the frame and internal glazing beads are not parallel (the glazing beads are not symmetrical).



[See video 6.07](#)

Open the sliding sash and, using a 3mm hex key, loosen the two screws located on the bracket at the mullion. Slide the lock sideways the required distance and retighten the screws.

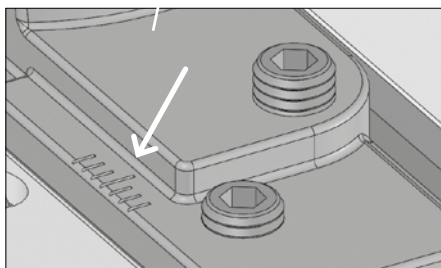

Use the millimetre guidelines. The longest line is "neutral" and should typically be flush with the edge of the groove.

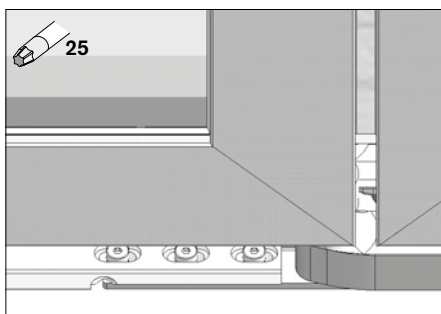

**Adjustment of the closing pressure.** Close the sash and check that the handles can be easily closed and the openings of the sash are parallel.

Otherwise to adjust from the outside while the door is closed, using a torx 25 drive loosen the three screws located on the top of the synchronisation rod. The closing pressure is automatically adjusted and the three screws can be retightened.



[See video 6.29](#)

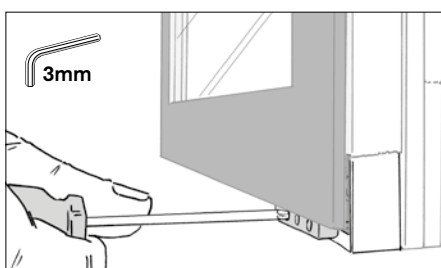

**Adjustment of the stop block position.** If the sash does not open fully or when opened if the handle clashes with the frame, the stop block position should be adjusted.

Using a 3mm hex key loosen the screws and reposition the stop block.

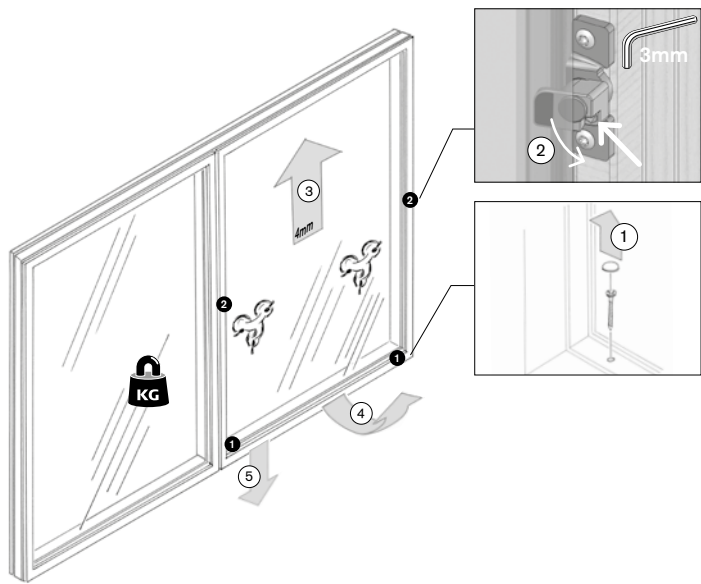
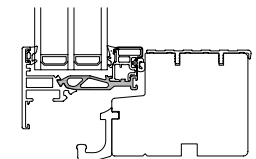
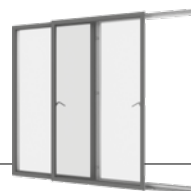

**Desashing the TRIPLE GLAZED fixed unit.**

1. Remove the internal cover cap with a flat bladed tool.
2. Using a 3mm hex key loosen the tumbler fittings located on each jamb: Press sash and frame together, firmly place the Allen key in the fitting and free the sash by turning each tumbler fitting 90° anticlockwise.
3. Support the sash and lift it approx. 4mm upwards,
4. Follow this by tilting it outwards at the bottom,
5. Complete the operation by lowering the sash down.

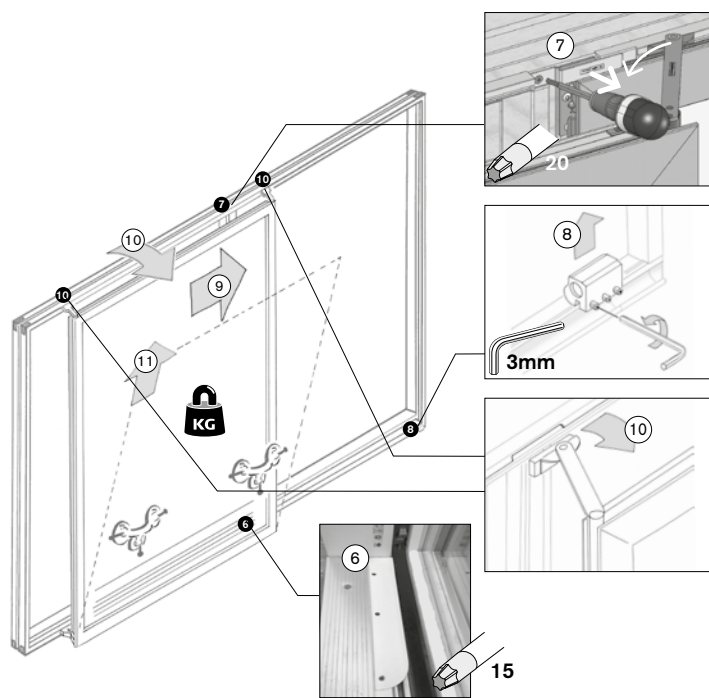

**Desashing the TRIPLE GLAZED opening unit.**

6. Using a torx 15 drive remove the anti-derailer lock at the threshold.
7. Using a torx 20 drive remove the anti-derailer lock at the head.
8. Using a 3mm hex key loosen and move the stop block backwards.
9. Slide the opening sash over the fixed sash until the top brackets are close to the recesses in the head.
10. Fully support the sash, slide it to the recesses at the top and tilt it out.
11. Lift the sash upwards and lower it down.

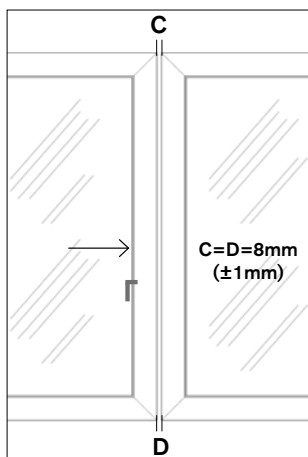
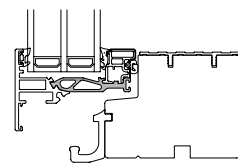
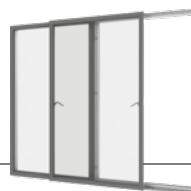

**Check that the sashes are level.** Close the sliding casement door and measure the distance between the sashes at the points C and D. The distance between the sashes must be:  $C \geq 8\text{mm}$  and  $D \geq 8\text{mm}$ .

Max 1mm difference between C and D measurements is allowed. If the result is not within the tolerance limit, adjust the installation of the frame. Otherwise the sliding door will not be able to function properly. It is much quicker to adjust the frame setup than to adjust the sliding door afterwards.



[See the video](#)

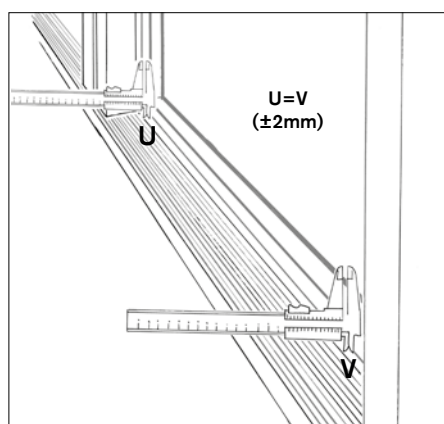

**Check closing alignment.** Close the sash without turning the espagnolette handle, and measure the distance between the glazing bead and the cill at the points U and V.

Max. 2mm difference between U and V measurements is allowed.

If the result is not within the tolerance limit, adjust again the sliding casement door sideways as per the process below.

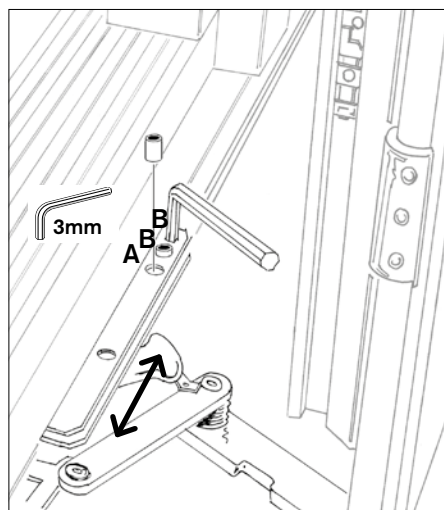

**Adjusting side to side:** Using a 3mm hex key remove the front screw (A) and loosen the two adjustment screws (B).

Move the truck as required and re-tighten the adjustment screws (B).

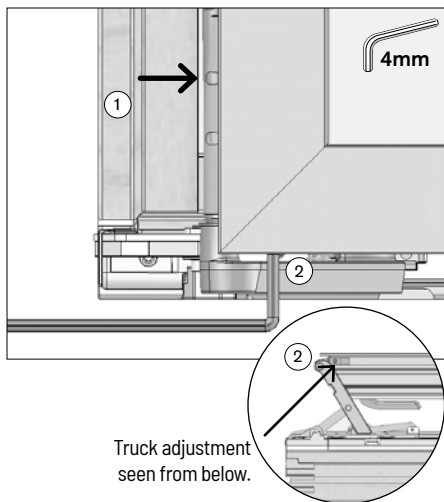
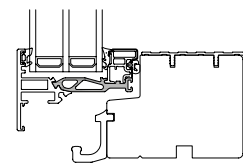

**Height adjustment.** If the sashes do not line up, the sliding sash is height adjustable at both ends:

Open the sash and slide it aside.

Support the sash and using a 4mm hex key loosen the 4 screws (1).

Remove the load from truck and turn the bearing adjustment (2) clockwise to lift the sash up.

Re-engage the 4 screws (1).

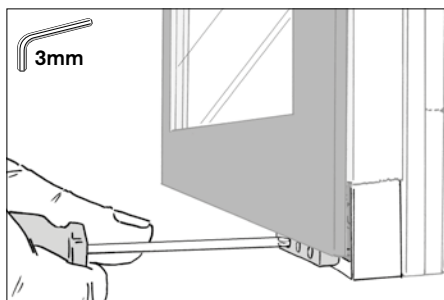

**Adjustment of the stop block position.** If the sash does not open fully or when opened if the handle clashes with the frame, the stop block position should be adjusted.

Using a 3mm hex key loosen the screws and reposition the stop block.

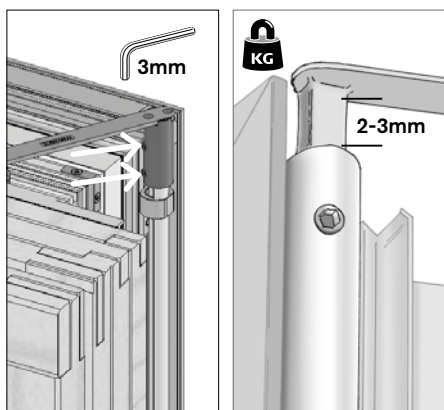

**Adjustment of the sliding sash top arm.** Make sure the top sliders can freely pass the neighbouring sash, otherwise the sliding sash arm should be adjusted.

Using a 3mm hex key loosen the screws on the side of the top arm and lift the arm to allow for typically 2-3mm free space between the guide rod and the top slider.

Re-engage the screws at the top arm.

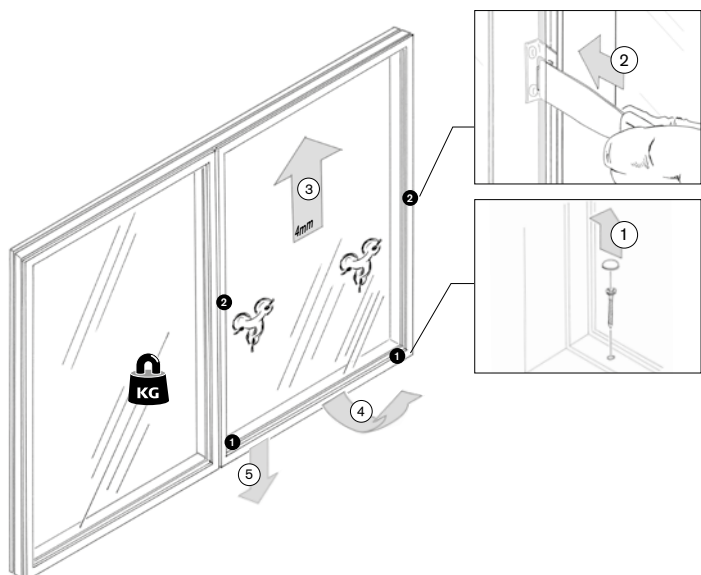
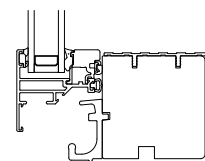

**Desashing the DOUBLE GLAZED fixed unit.**

1. Remove the internal cover cap with a flat bladed tool.
2. Push the fittings located on the jamb with a flat bladed tool to release them.
3. Support the sash and lift it approx. 4mm upwards,
4. Follow this by tilting it outwards at the bottom,
5. Complete the operation by lowering the sash down.

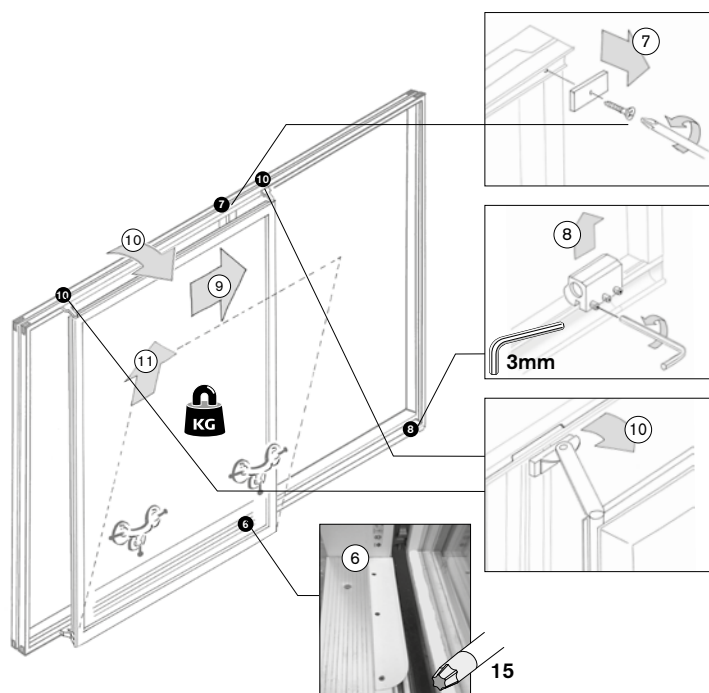

**Desashing the DOUBLE GLAZED opening unit.**

6. Using a torx 15 drive remove the anti-derailer lock at the threshold.
7. Using a torx 15 drive remove the anti-derailer lock at the head.
8. Using a 3mm hex key loosen and move the stop block backwards.
9. Slide the opening sash over the fixed sash until the top brackets are close to the recesses in the head.
10. Fully support the sash, slide it to the recesses at the top and tilt it out.
11. Lift the sash upwards and lower it down.

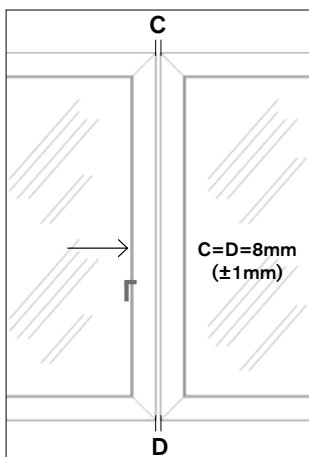
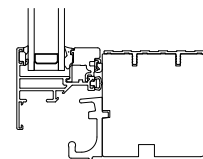

**Check that the sashes are level.** Close the sliding casement door and measure the distance between the sashes at the points C and D. The distance between the sashes must be:  $C \geq 8\text{mm}$  and  $D \geq 8\text{mm}$ .

Max 1mm difference between C and D measurements is allowed. If the result is not within the tolerance limit, adjust the installation of the frame. Otherwise the sliding door will not be able to function properly. It is much quicker to adjust the frame setup than to adjust the sliding door afterwards.



[See the video](#)

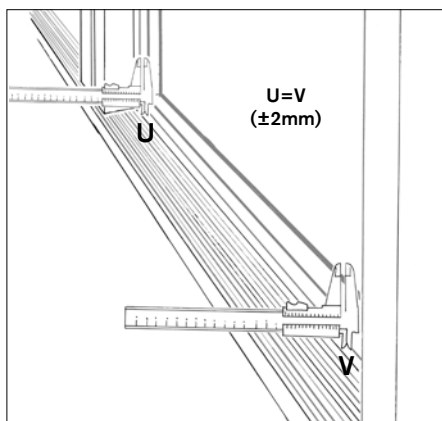

**Check closing alignment.** Close the sash without turning the espagnolette handle, and measure the distance between the glazing bead and the cill at the points U and V.

Max. 2mm difference between U and V measurements is allowed.

If the result is not within the tolerance limit, adjust again the sliding casement door sideways as per the process below.

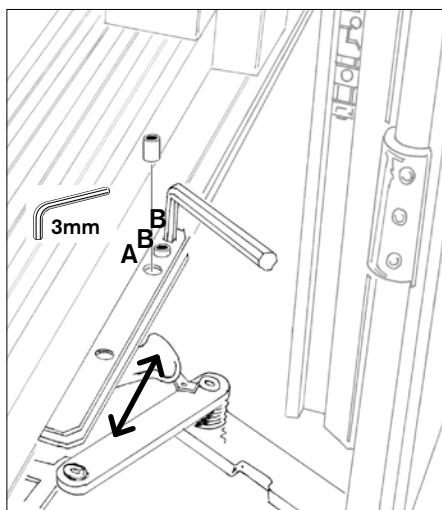

**Adjusting side to side:** Using a 3mm hex key remove the front screw (A) and loosen the two adjustment screws (B).

Move the truck as required and re-tighten the adjustment screws (B).

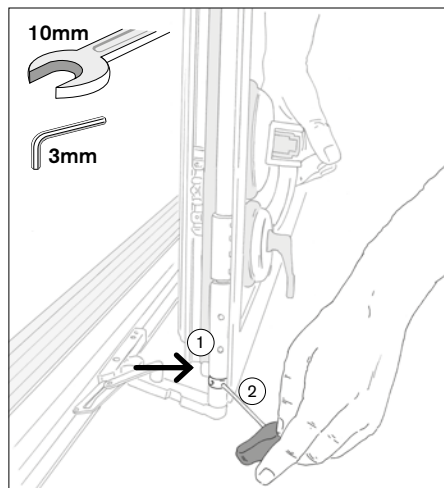
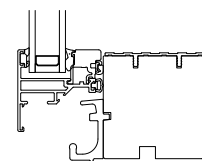

**Height adjustment.** If the sashes do not line up, the sliding sash is height adjustable at both ends:

Open the sash and slide it aside. Loosen the fixing screw (1) with a 10mm spanner, remove the load from truck and turn the bearing adjustment (2) anticlockwise using a 3mm hex key to lift the frame up.

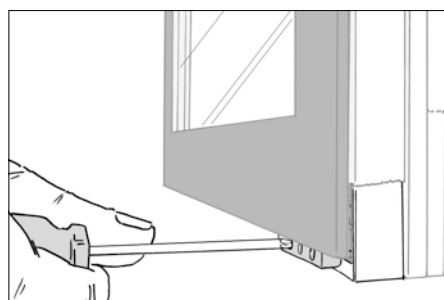

**Adjustment of the stop block position.** If the sash does not open fully or when opened if the handle clashes with the frame, the stop block position should be adjusted. Using a 3mm hex key loosen the screws and reposition the stop block.

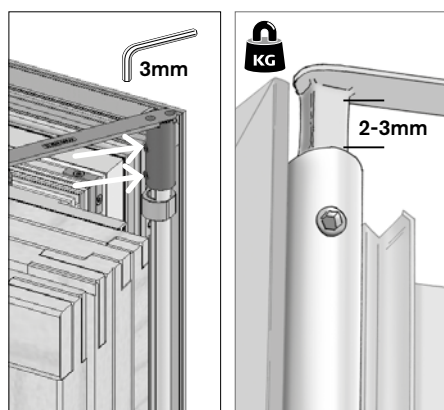

**Adjustment of the sliding sash top arm.** Make sure the top sliders can freely pass the neighbouring sash, otherwise the sliding sash arm should be adjusted.

Using a 3mm hex key loosen the screws on the side of the top arm and lift the arm to allow for typically 2-3mm free space between the guide rod and the top slider. Re-engage the screws at the top arm.

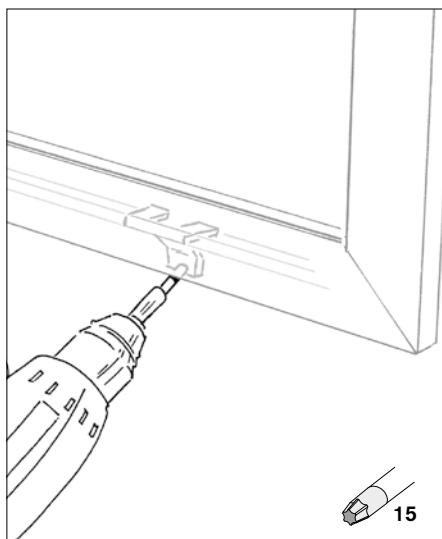

**Desashing:** Unscrew the fittings located to the underside of the sash using a torx 15 drive.

**N.B.** The sash is detached when released at the bottom.

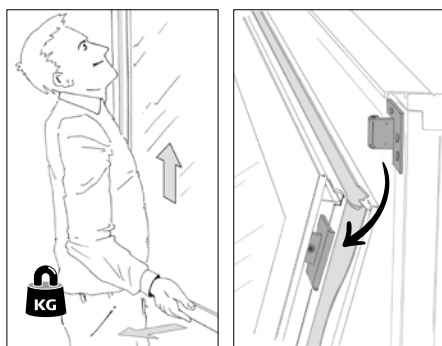

Lift the sash upwards, pull towards you and lower it.



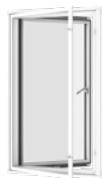

## VELFAC 200 / Internal sash (2+1, 3+1)

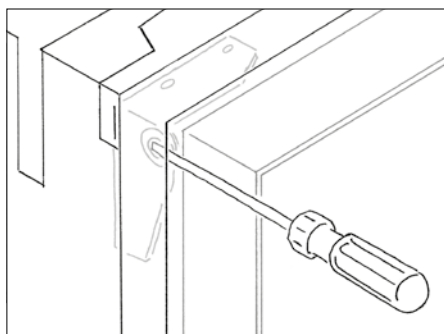

**Desashing:** Using a flat bladed screwdriver hold down the top hinge pin, and tip out the sash.

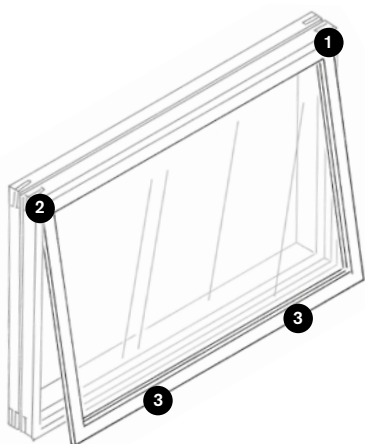

**N.B.** The top hung inner sash is shown here. Operation of the sidehung inner sash is the same but rotated by 90°. The top-hung inner sash may only be opened for cleaning purposes, in which case it must be removed.

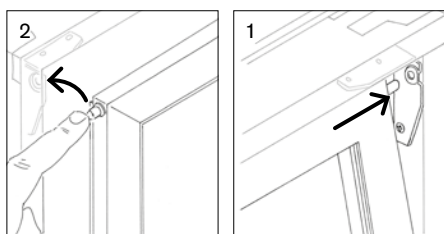

**Re-engaging:** Place one hinge pin in the fitting (1), hold down the other hinge pin (2) and click the sash into position.

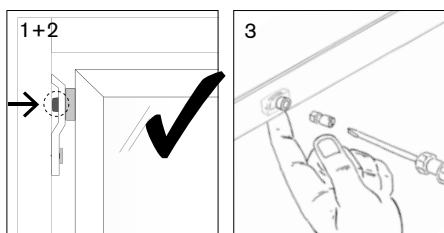

Make sure, that the pins are properly engaged in the fitting (1+2). Now close the sash by using the handles or the screws - hold down the latch while inserting the screw (3).

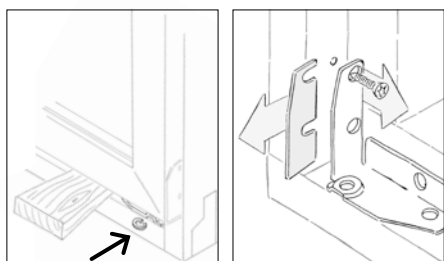

**Height / side adjustment:** Insert a washer or remove the plate under the hinge fittings.

VELFAC 200 / 180° hinge

for casement door

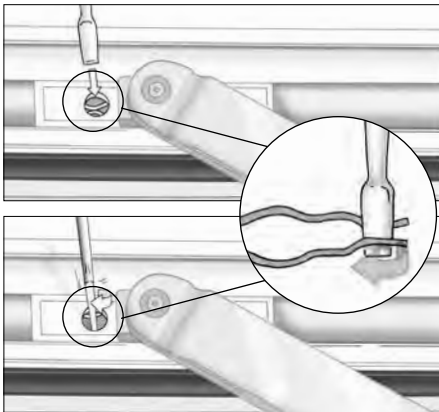

**Desashing the friction arm, if any:** Release the friction arm by placing a flat bladed screwdriver within the clip and rotate through 90°. Now release the friction arm from the sash.

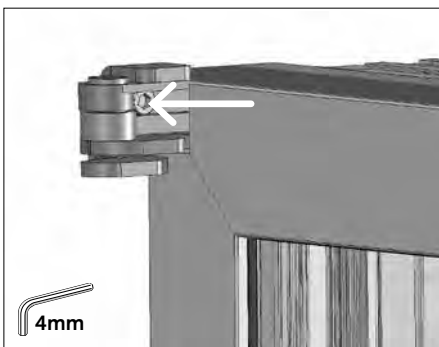

**Desashing the top hinge:** Using a 4mm hex key unscrew the safety device and remove it.

**When re-engaging:** Tighten the safety device again (5Nm).

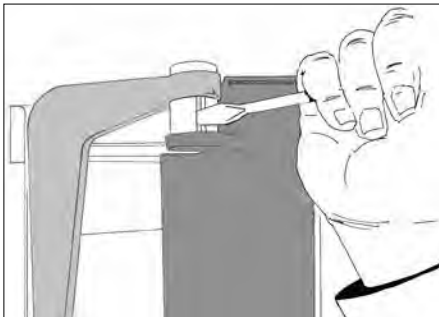

Remove the retaining ring at the top of the sash with a flat bladed screwdriver.

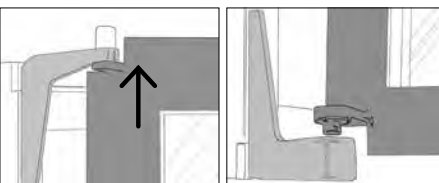

The sash can now be lifted to a point where it is released at the bottom and can be removed.

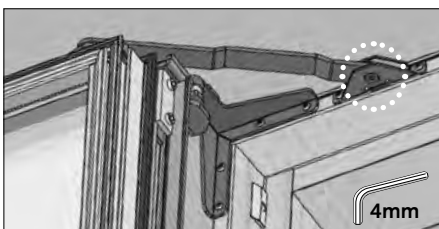

**Adjustment of friction arm:** Using a 4mm hex key loosen or tighten the screw. Do not lubricate!



**Desashing:** Open the window (90°). Release the bracket arm from the head by inserting a flat bladed screwdriver into the gap between the bracket arm and locking plate. Tilt the locking plate slightly outwards and click out the arm. Now lift the sash out.

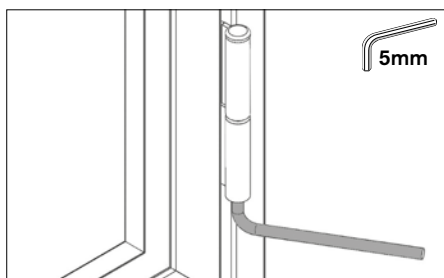

**Height adjusting:** Using a 5mm hex key turn the screw in the bottom hinge to adjust the sash up and down as required. For sashes above 120mm in height adjustments are required to all hinges.

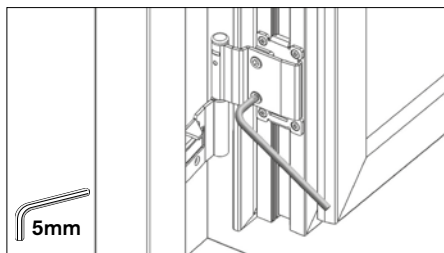

**Adjusting side to side:** Using a 5mm hex key turn both screws per hinge to adjust the sash left and right as required.  
**NB.** To avoid damage / distortion of hardware adjust the screws equally in turn rotating a maximum quarter turn at a time.

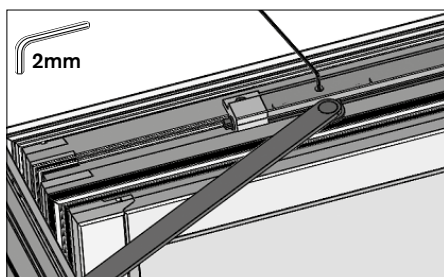

**Adjusting the handle operated brake:** Open the window until the tail grub screw is visible in the hole in the track cover above the window. Insert a 2mm hex key through the hole in the cover rail, then turn clockwise to tighten the brake, usually 10-20°.

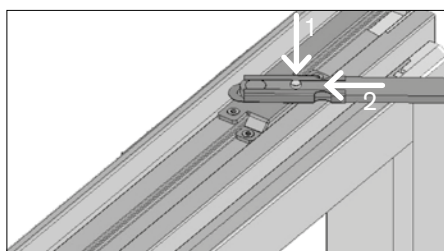

**Small windows with friction arm (no handle operated brake).**  
**Desashing the sash:** Open the window. Release the locking plates by holding down the lock button (1) while pushing the locking plate outwards (2).

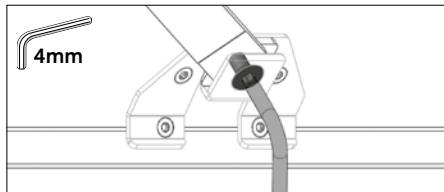

**Adjusting the friction arm:** Using a 4mm hex key loosen or tighten the screw as required.

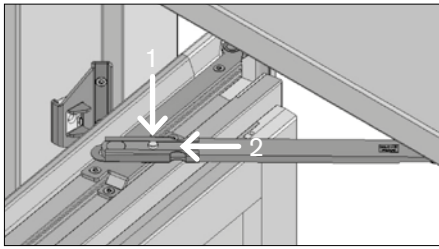
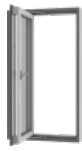

**Desashing:** Open the window to maximum position. Release the locking plates by holding down the lock button (1) while pushing the locking plate outwards (2) - top and bottom.

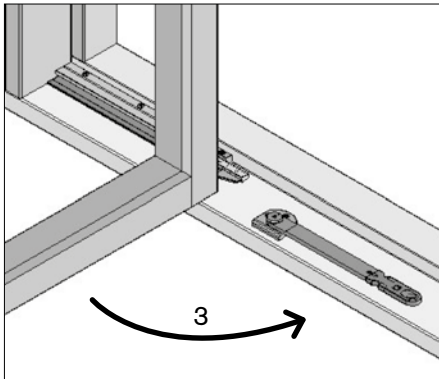

Detach the guidearms from the rotating point at the sash and place the guidearms parallel to the frame pointing away from the guiderails (3).

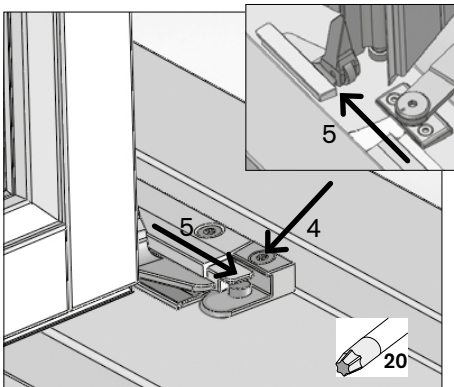

Using a torx 20 key remove the slider stop top and bottom (4) and slide the hinges out of the rail (5).

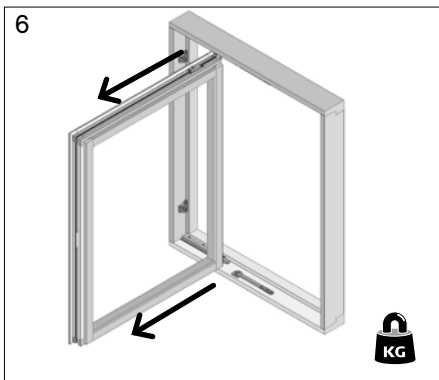

Slide the sash vertically out of the frame (6).  
**NB.** Both top and bottom hinge must be detached at the same time.

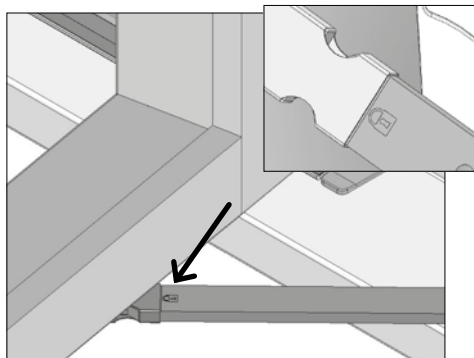

**When reinstating the sash** ensure both locking plates are in the correct position, this is signified by the locking symbols being visible.

If required the glide rails only can be lubricated using a teflon based oil.

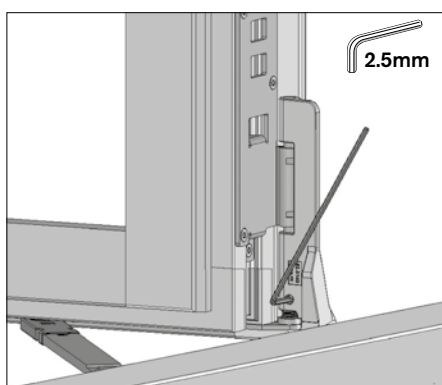

**Height adjusting in the bottom hinge.** Open the window to maximum position. Using a 2.5mm hex key loosened the set screw located at the bottom of the hinge.

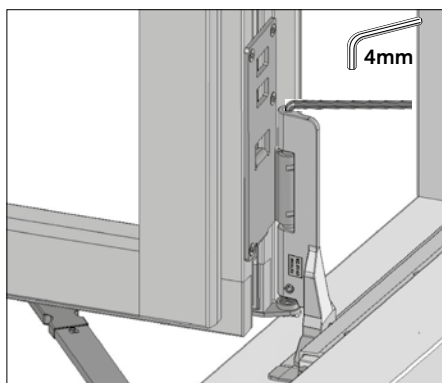

To adjust the sash up and down using a 4mm hex key turn the set screw located in the top of the bottom hinge in the required direction.

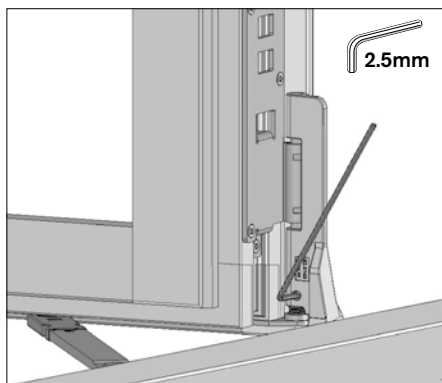

Following adjustment using a 2.5mm hex key ensure the set screw at the base of the hinge is tightened

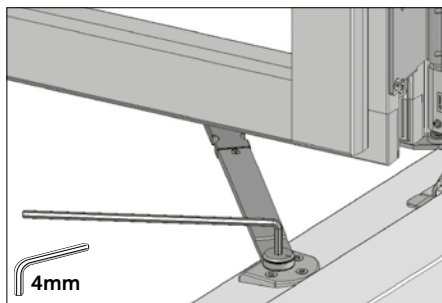

**Adjusting side to side:** Using a 4mm hex key turn the adjustment cam screw at the top and / or at the bottom of the frame.

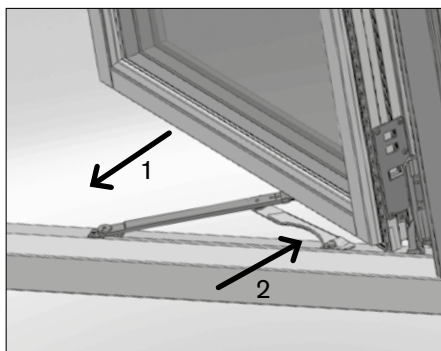

**Desashing:** Open the window until the ventilation position restrictor will engage at approx. 30° opening. To disengage the restrictor pull the sash back slightly (1) and detach the restrictor (2). If the sash is fully reversed into the cleaning position, the restrictor will engage and can be disengaged the same way.

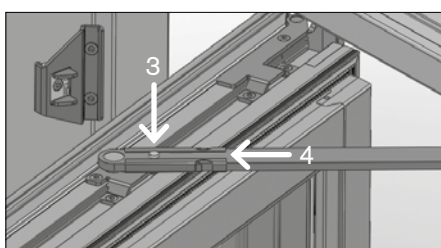

Release the locking plates by holding down the lock button (3) while pushing the locking plate outwards (4) - top and bottom.

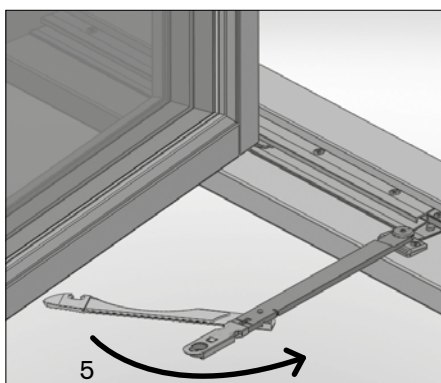

Detach the guidearms from the rotating point at the sash using a flat bladed screwdriver to unclick them, and turn the guidearms away from the sash (5).

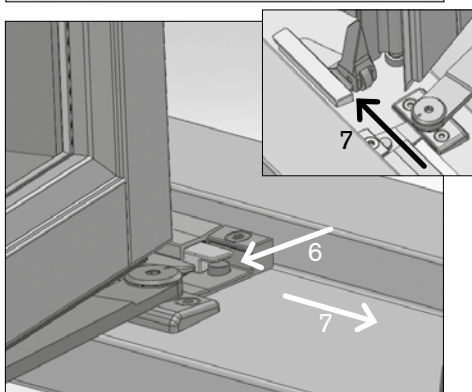

Open the window to maximum position. Press the knobs at the end stops into the consoles (6) using a flat bladed screwdriver and slide the hinges out of the rail (7).

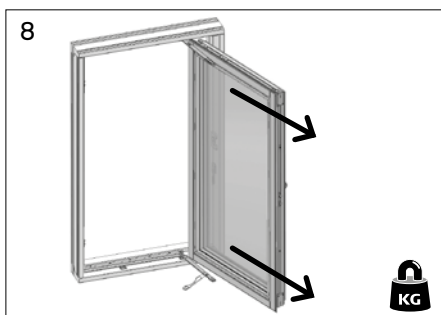

Slide the sash vertically out of the frame (8). **NB.** Both top and bottom hinge must be detached at the same time.

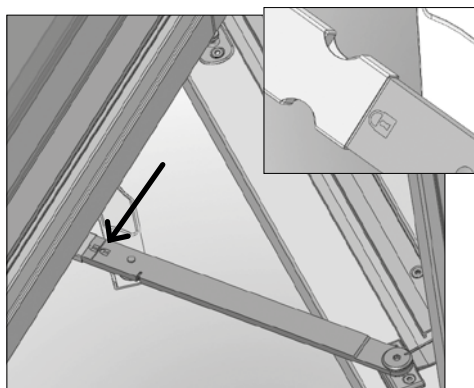

**When reinstating the sash** ensure both locking plates are in the correct position, this is signified by the locking symbols being visible.

If required the glide rails only can be lubricated using a teflon based oil.

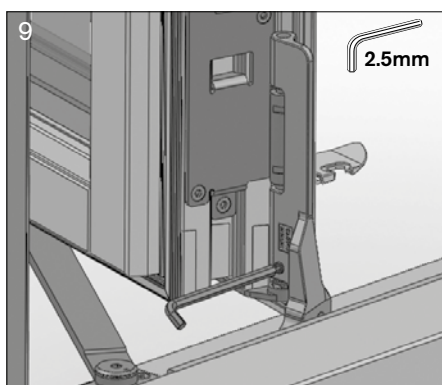

**Height adjusting in the bottom hinge.** Open the window to maximum position. Using a 2.5mm hex key loosen the set screw located at the base of the hinge (9).

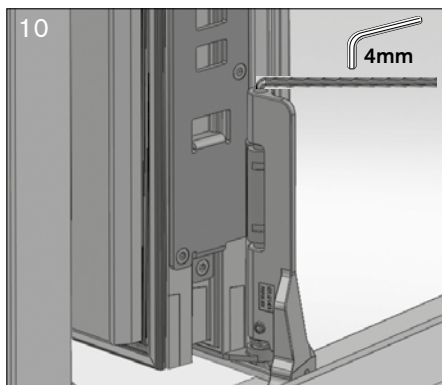

Adjust the sash up or down by turning the set screw placed on top of the bottom hinge (10). After adjusting tighten the set screw placed horizontally at the hinge (9).

Using a 4mm hex key adjust the sash up or down by turning the set screw located in the top of the hinge (10). Once adjusted using a 2.5mm hex key re-tighten the set screw at the base of the hinge (9).

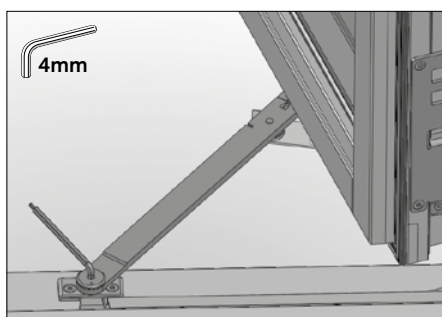

**Adjusting side to side:** Turn the adjustment screw in the sash mounting at the top and / or at the bottom of the frame.

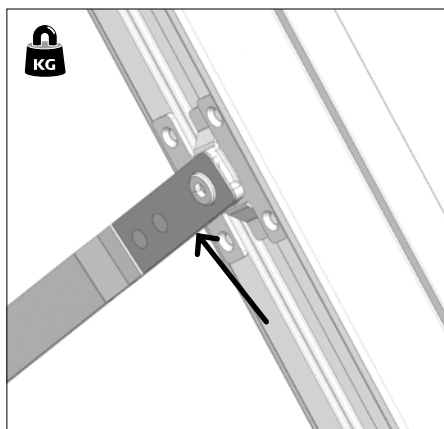

**Desashing:** Open the window to maximum position. Support the sash and dismount the balance arms by inserting a flat bladed screwdriver into the gap between the balance arm and locking plate, tilt the locking plate outwards and click out the balance arm on both sides of the sash. Turn the balance arm downward after disassembly.

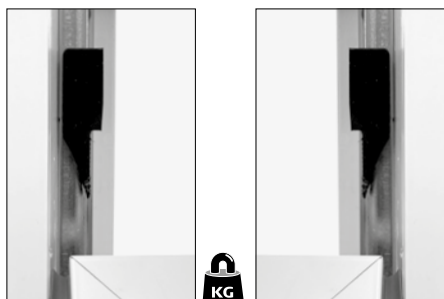

Fit a VELFAC sash derailer on the sash bracket on both sides of the sash. Support the sash and move it upwards - the movement will derail the sash. **NOTE:** Care should be taken when handling as the sash will now be loose.

Item number: 82.0184 (left) and 82.0183 (right).

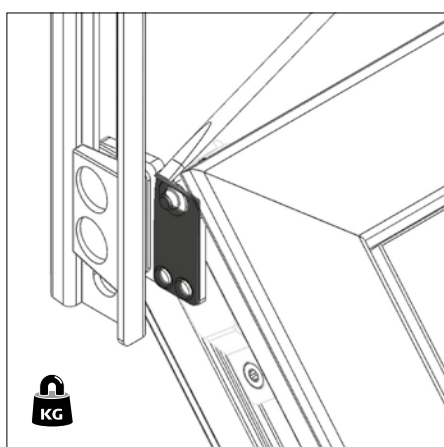

An alternative if you do not have sash derailleurs, you can instead do the following:  
Support the sash while desashing the sash bracket (both sides), using a flat bladed screwdriver to unclick them. The sash and frame are now separated.

**NB.** The element is illustrated without frame profile to give a better view of the bracket.

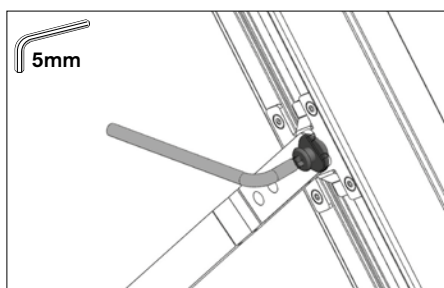

**Height adjusting:** Using a 5mm hex key turn the screw to adjust the sash up and down as required (90° = 2mm).

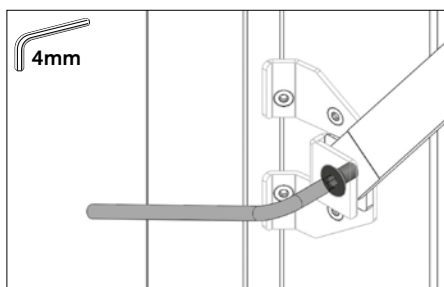

**Adjusting the friction arm:** Using a 4mm hex key adjust both arms equally by loosening or tightening the screw located in the friction arm.

**NB.** Do not oil!





# VELFAC Ribo / Tophung reversible window

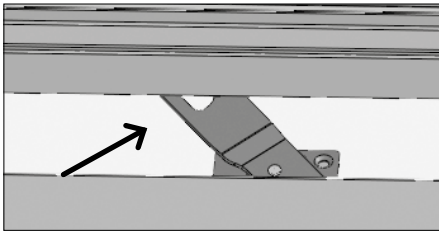

**Desashing:** Open the sash until the safety restrictor is activated. Pull back the sash slightly and detach the restrictor.

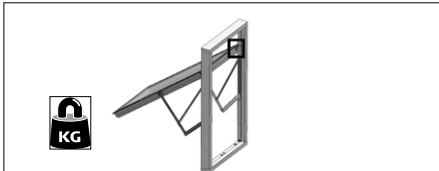

Support the sash and set the gliders free: Squeeze the pointed screws towards each other with pointed pliers and free the sash from the frame.

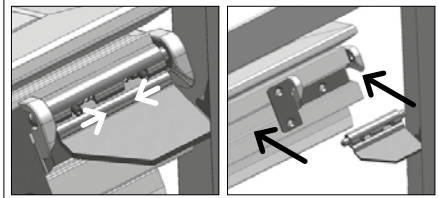

Continue supporting the sash and remove the sash mounting on both sides: Place a flat bladed screwdriver in the small hole next to the Unlock arrow and pull the the tool in the direction of the arrow.

The sash mountings may now be released from the sash.

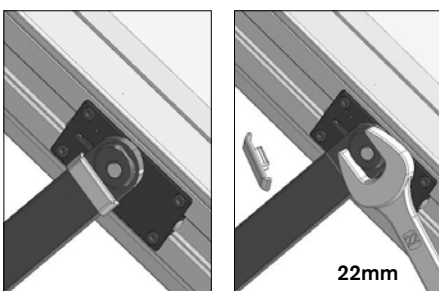
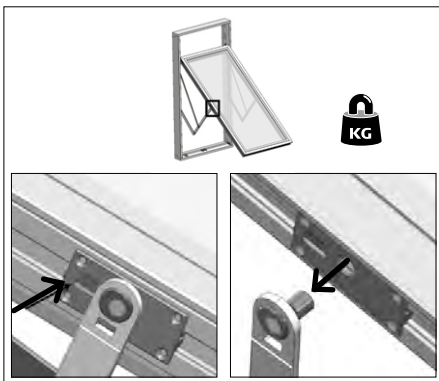

**Height adjusting:** With a 22mm open-ended spanner turn the adjusting rivet on both sides of the sash as required. Remove the plastic protection plate while adjusting.

VELFAC Ribo / Casement door

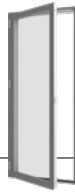

**Desashing:** Open the window (90°). Release the bracket arm from the head by inserting a flat bladed screwdriver into the gap between the bracket arm and locking plate. Tilt the locking plate slightly outwards and click out the arm. Now lift the sash out.

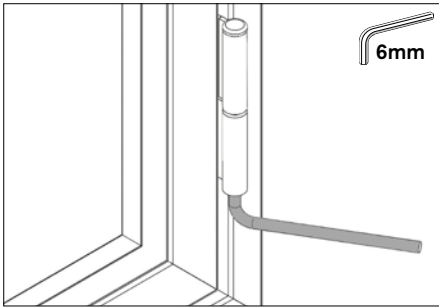

**Height adjusting:** Using a 6mm hex key turn the screw in the bottom of all hinges to adjust the sash up and down as required (+/-2.5mm).

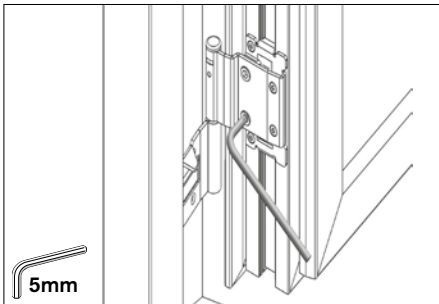

**Adjusting side to side:** Using a 5mm hex key turn both screws per hinge to adjust the sash left and right as required. **NB.** to avoid damaging the hardware screws must be adjusted equally with a maximum quarter turn each time.

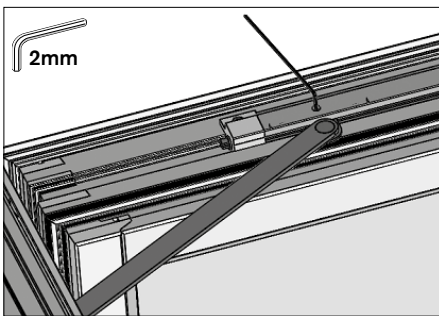

**Adjusting the handle operated brake:** Open the door until the tail grub screw is visible in the hole in the track cover above the door. Insert a 2mm hex key through the hole in the cover rail, then turn clockwise to tighten the brake, usually 10-20°.

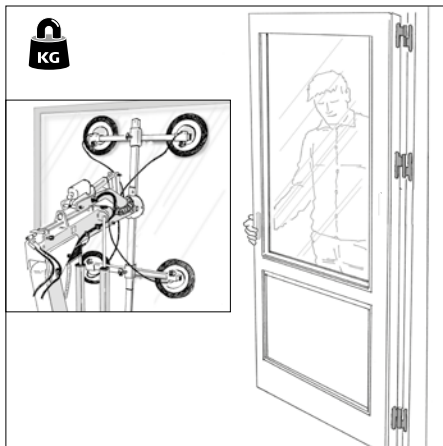

**Desashing:** Open the patio door.  
Lift it out using appropriate lifting equipment.

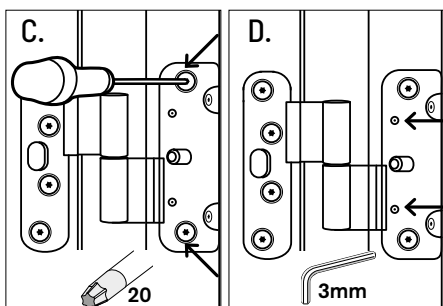

**Adjusting side to side:** Using a Torx 20 loosen the two hinge screws on the frame with 1-2 turns of the screwdriver (C) and adjust by loosening or tightening the Allen screws (D) using a 3mm hex key.



[See video](#)

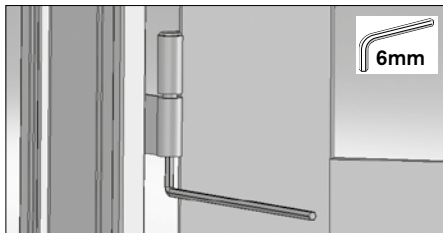

**Height adjusting:** Using a 6mm hex key turn the screw in the bottom of all hinges to adjust the sash up and down as required (+/-2.5mm).

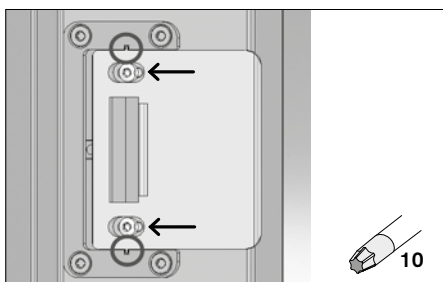

**Adjusting closing pressure:** Using a Torx 10 drive loosen the screws and remove the cover plate from the striking plate, this will expose two pins which can be cut off. Reinstall the coverplate.

In double-leaf doors the closing pressure might be further adjusted by turning the striking plates at head and threshold 90° clockwise or anticlockwise. At the threshold a coverplate needs to be removed before adjusting.

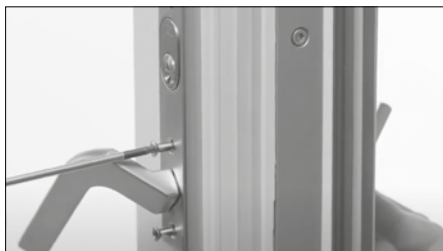
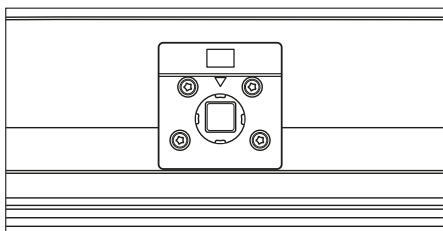

**Installation of espagnolette handle with cylinder lock:** Handles and cylinders are supplied as a loose item to be site installed. Instructions for installation are also supplied. Further information can be obtained by visiting the VELFAC website where videos are available to view.



[Video - 1 cylinder](#)



[Video - 2 cylinders](#)

VELFAC Ribo / Sliding door

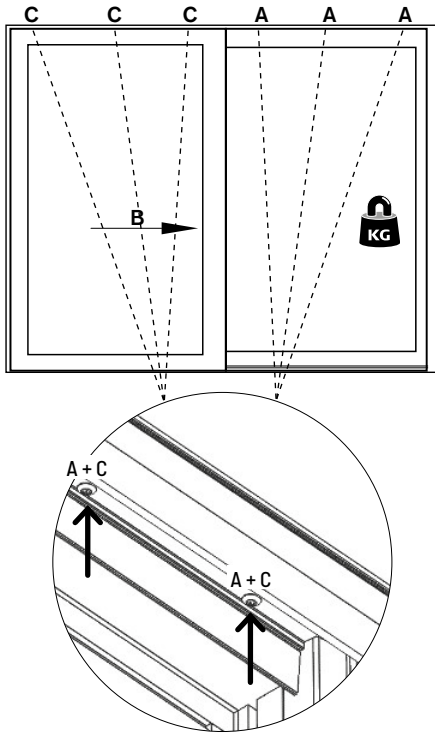

**Dismount the sliding sash as follows:**

- A. Loosen the screws of the guide rail on the upper track on the fixed sash.
- B. Slide the door in front of the fixed sash.
- C. Loosen the remaining screws in the track.
- D. Tilt the door out of the threshold - while in front of the fixed sash - and lift it out of the guide rail on the bottom.

**Reinstate the sliding sash in reverse order, retain screws and check that the door glides smoothly.**

**Adjustments.**

- E. Adjust the closing pressure using a 9mm open ended spanner to turn the knobs at the closing side of the sliding door.
- F. Adjust the gasket pressure using a 4mm hex key through the small holes positioned at the 'the mullion' on the external side of the opening sash.

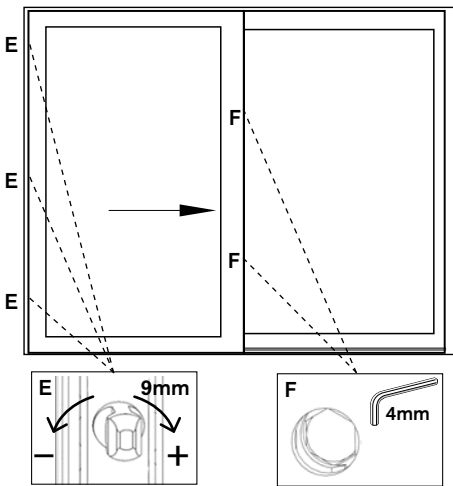

VELFAC Ribo / Wood/aluminium door

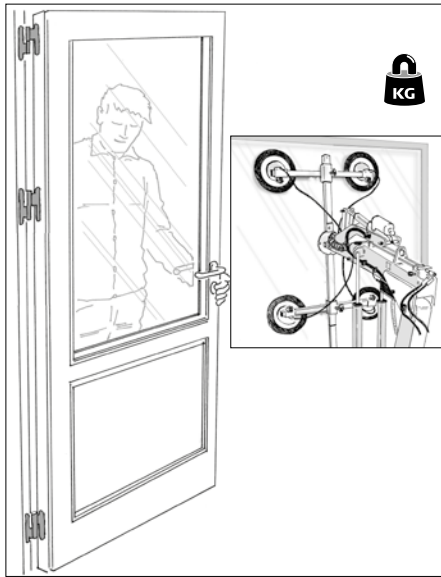

**Desashing:** Open the entrance door.  
Lift it out using appropriate lifting equipment.

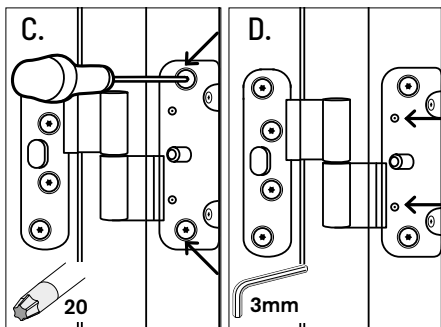

**Adjusting side to side:** Using a Torx 20 loosen the two hinge screws on the frame with 1-2 turns of the screwdriver (C) and adjust by loosening or tightening the Allen screws (D) using a 3mm hex key.



[See video](#)

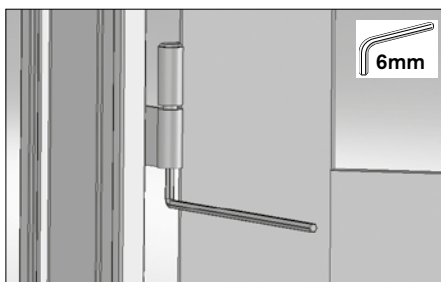

**Height adjusting:** Using a 6mm hex key turn the screw in the bottom of all hinges to adjust the sash up and down as required (+/-2.5mm).

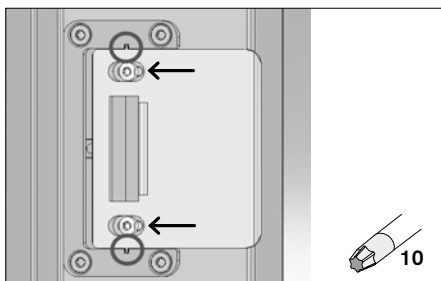

**Adjusting closing pressure:** Using a Torx 10 drive loosen the screws and remove the cover plate from the striking plate, this will expose two pins which can be cut off. Reinstall the coverplate.

In double-leaf doors the closing pressure might be further adjusted by turning the striking plates at head and threshold 90° clockwise or anticlockwise. At the threshold a cover-plate needs to be removed before adjusting.

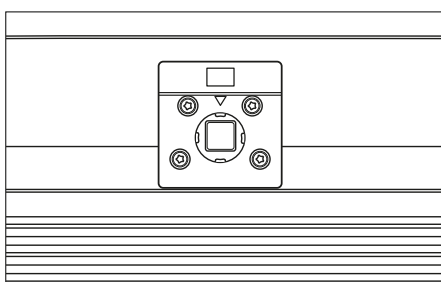

VELFAC Aluminium door



1/2 – with barrel hinge

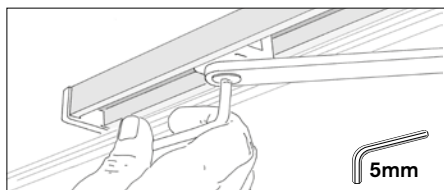

**Desashing:** Open the door and support the door leaf. To disengage the door closer i.e. TS83 or TS93 using a 5mm hex key remove the screw in the door closer arm and turn the arm to one side.

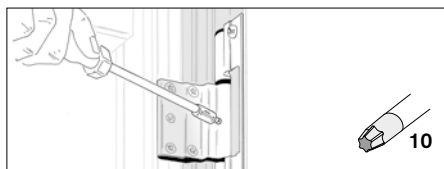

Using a Torx 10 drive turn the screw on each of the hinges. Close the door.

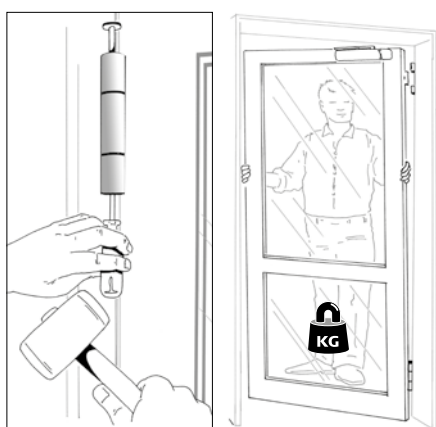

Remove the hinge pin by knocking it upwards and lift the door out. If the hinges are contaminated with dust, clean with warm water only, do not apply lubricants.

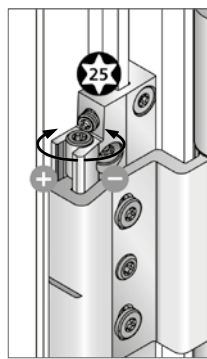
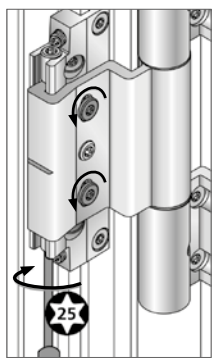

**To adjust the height:** Open the door and support the door leaf. On all hinges using a Torx 25 drive, loosen the clamp screws fastened to the hinges at the door leaf, then loosen the bottom set screws (approx. 3 turns).

Now using a Torx 25 drive adjust the height  $\pm 3$ mm by using the upper set screw.

**NB:** the lower hinge must support the door.

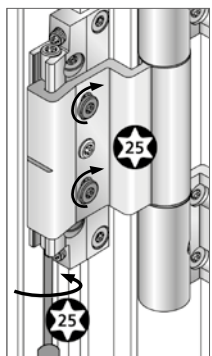

Tighten the clamp screws again and bring the set screws into position.



**Adjusting side to side /adjusting tolerance gaps:** Open the door and support the door leaf. Adjusting tolerance gaps is done in the upper hinges of the door leaf using a Torx 25 drive.

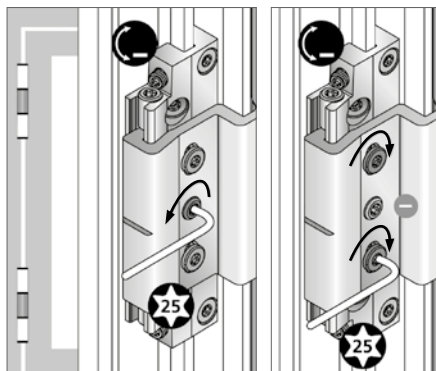

To close tolerance gaps:

1. Loosen the adjusting screw
2. Tighten both clamp screws as required.

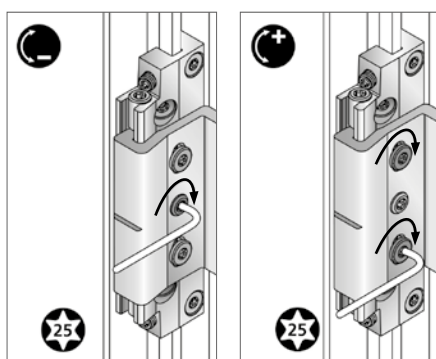

3. Re-tighten the adjusting screw
4. Secure both clamp screws.
5. Finally counter secure the adjustment screw.

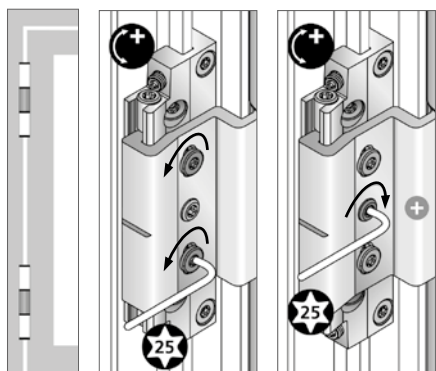

To open tolerance gaps:

1. Loosen the clamp screws simultaneously (max. 2 rotations).
2. Tighten the adjusting screw as required.

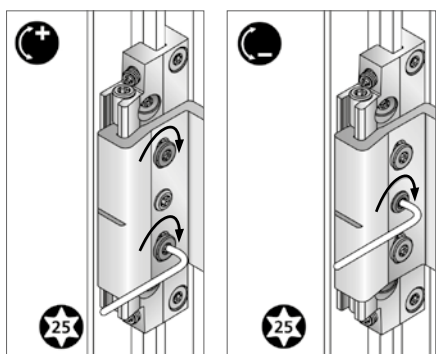

3. Re-tighten the clamp screws.
4. Finally counter secure the adjustment screw.

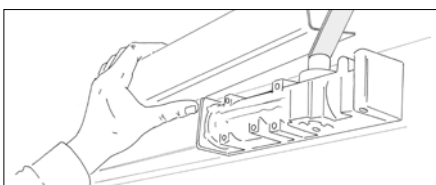

**Adjusting the door closer:** Slide the cover off the door closer and follow the instructions provided on the door closer.

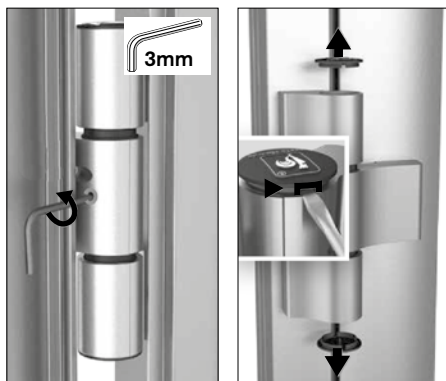
**Desashing:**

1. Open the door and support the door leaf.
2. Using a 3mm hex key loosen the setscrew in the middle of all hinges.
3. Remove the cover caps.

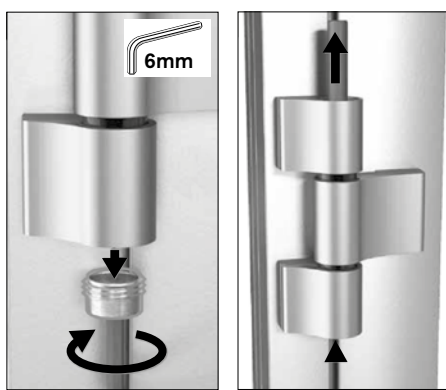

4. Using a 6mm hex key unscrew the threaded drum at the base of the hinge.
5. Knock the pins upwards using a punch and pull out past the middle section of the hinge.
6. The pin is secured by the set screw which may need loosening further to ensure the pin is completely disengaged.
7. Lift the door leaf out.

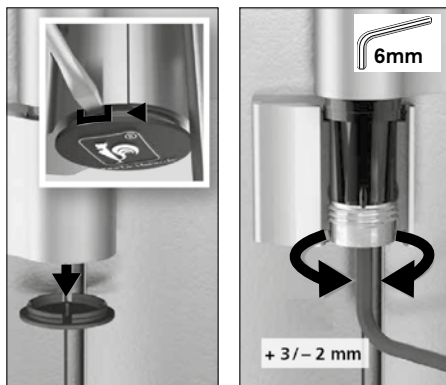
**Adjusting the height:**

1. Remove the cap from the bottom of the bottom hinge.
2. Using a 6mm hex key tighten or loosen the screw to move the door up or down (+3/-2mm).

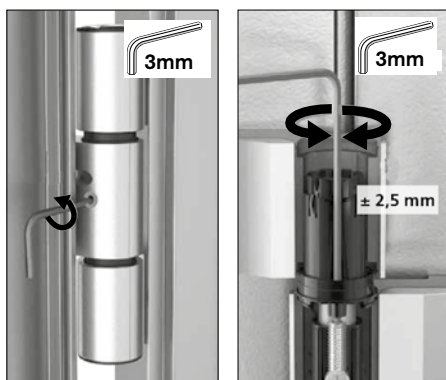
**Adjusting side to side:**

1. Using a 3mm hex key loosen the setscrew in the middle of all hinges ( $\times 1.5$ ).
2. Remove the top cover caps.
3. Using a 3mm hex key tighten or loosen the screw in the middle part of the hinges ( $\pm 2.5$ mm).
4. Tighten the setscrews.



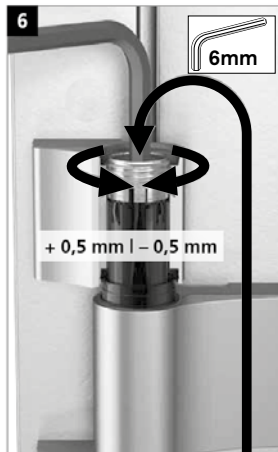
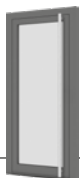

**Door Leaf Closing Pressure Adjustment:**

1. Remove the dust cover caps located at the top and bottom of the hinge using a flat bladed tool.
2. Using a 6mm hex key unscrew the threaded drum at the base of the hinge.
- 3+4. Rotate the drum through 180 degrees and screw back into the hinge chamber.
5. By loosening or tightening the drum the closing pressure on the door leaf will increase or decrease.
6. Follow the above procedure for the drums located in the top of each hinge chamber.
- 5+6. Find the mark on the collar at the top and bottom of the hinge. In the table below find the correct collar position according to adjustment intended.
7. Once all adjustments have been made and the required closing force has been achieved re-instate the hinge cover caps.

5 + 6		A	B	
			▶	- 0,5 mm
			▶	0 mm
			▶	+ 0,5 mm

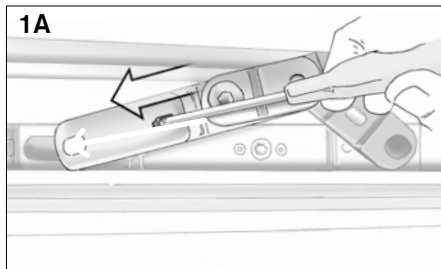
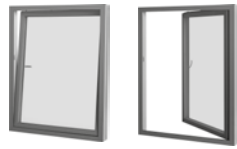
**Desashing the opening sash.****1. Free the top scissor fitting.**

1A. Tilt the window/door (if sidehung only, open sidehung). At the top scissor fitting, use a flat bladed screwdriver to press the spring-lock mechanism down.

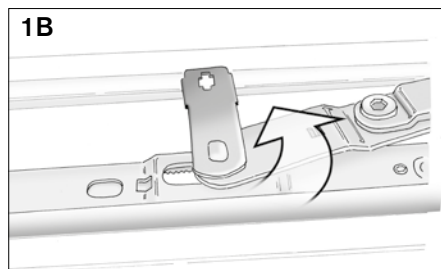

1B. Rotate the catch to one side.

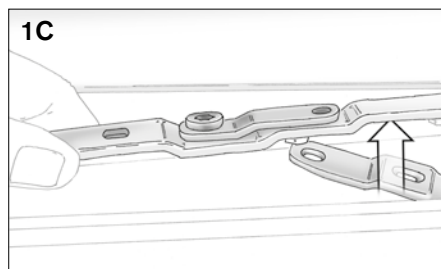

1C. Lift away the scissor fitting to disconnect sash and frame.

**N.B.** When the sash mounting is released the sash will be independent of the timber mainframe.

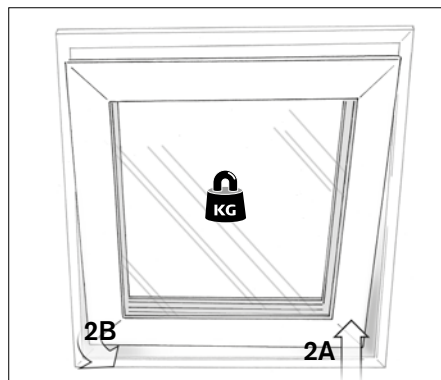
**2. Desashing the sash:**

On a bottom hung configuration to release the sash from the timber mainframe complete the steps above (1A-1C).

2A. Then lift the sash on the hinge side

2B. and turn the window inwards (2B) to fully disengage.

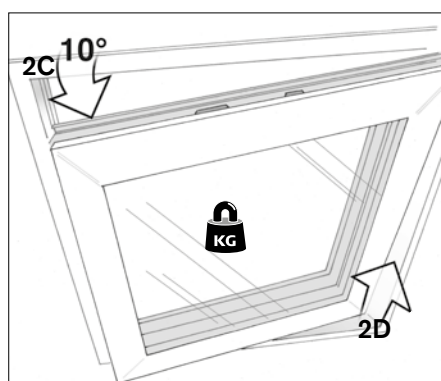

On a side hung configuration open the window to allow access into the hardware and completed the steps above (1A-1C).

2C. Turn the window approx. 10° inwards

2D. and lift off the sash in the hinge side.

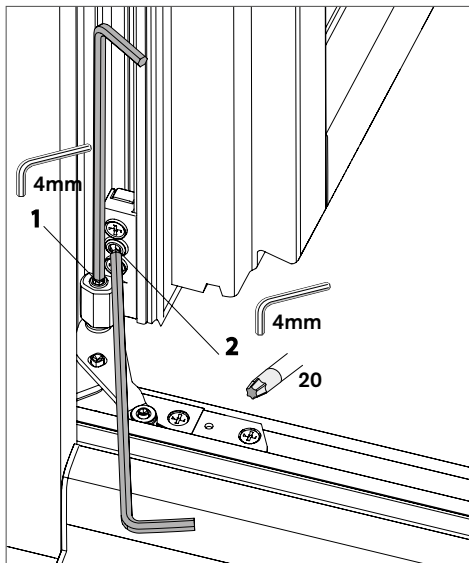
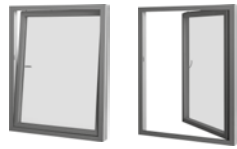

[See the video](#)

**Height adjustment.**

1. Using a 4mm hex key turn the adjustment screw clockwise or counter-clockwise to adjust the sash up or down (+2.0mm/ -1.5mm).



[See the video](#)

**Side to side adjustment at the bottom.**

2. Using a 4mm hex key adjust the sash bottom towards the hinge side by loosening the Allen screw and then tighten the torx screws using a Torx 20 drive (+2.5mm/-1.5mm).

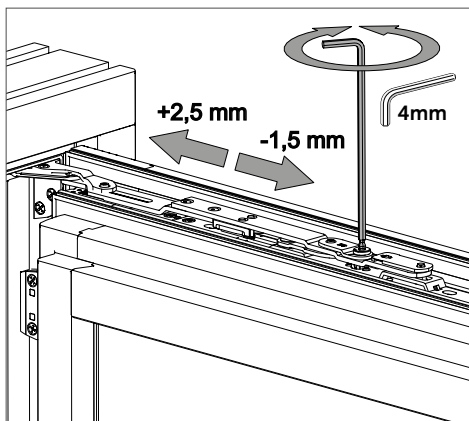
**Side to side adjustment at the top.**

Using a 4mm hex key adjust the top of the sash by the help of the adjustment screw on the scissor arm (+2.5mm/-1.5mm).

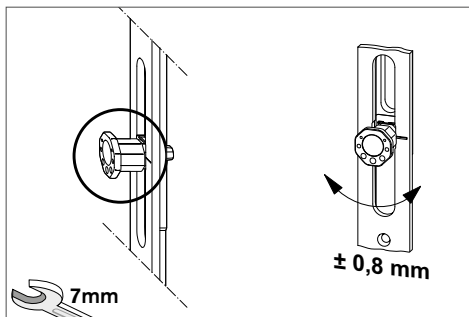
**Adjustment of closing pressure.**

Using a 7mm spanner turn the locking mechanism at the top (+/- 0.8mm)...

... and at the bottom (+/- 0.8mm)

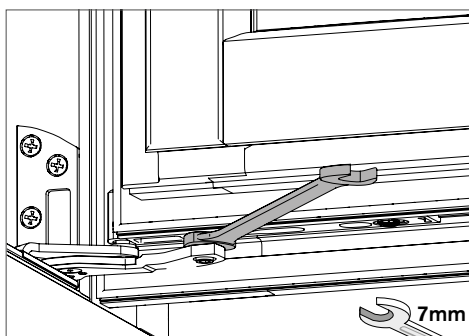

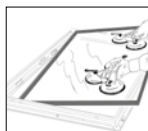

**Glass breakage:** To order replacement glass units you will need the Order Number and the Position Number. These are shown on the unique ID tag allocated to each window, generally located in the bottom left rebate of any opening unit. For fixed units the ID Tag is located in either the right or left hand upper corner of the timber mainframe.

If no ID tags are visible, the required information is available on the glass spacer bar. This information is critical to ensure the correct specification of glass is re-supplied by the After-sales Department.



[A. Thermally broken sash](#)



[B. Aluminium sash](#)



If works are to be undertaken by a third party we recommend viewing of the relevant video prior to undertaking the works: For VELFAC 200 ENERGY (TGU) and VELFAC 200i (DGU) with thermally broken sash profiles, please use the first link. For VELFAC 200 alu (DGU) with aluminium sash profiles, please use the second link.

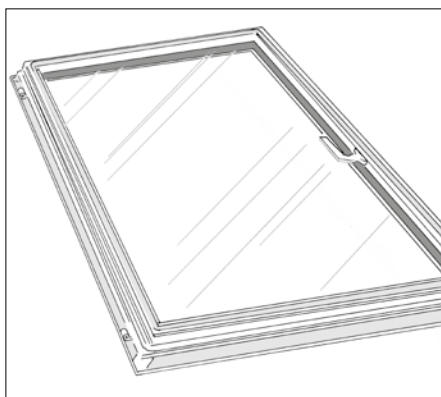

**Desash** the complete opening element with the glass in place (as shown on the opening function page in the VELFAC 200 Desashing and Adjustment Guide).

Place the sash onto trestles with the internal side facing upwards.

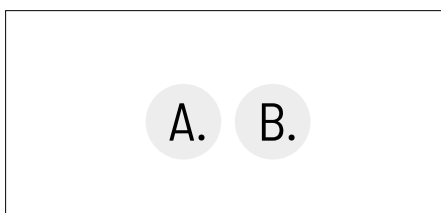

**A. or B.?** Choose the correct method according to the following differences:

- A. VELFAC 200 ENERGY and VELFAC 200i with thermally broken sash profiles.
- B. VELFAC 200 with unbroken aluminium sash profile.

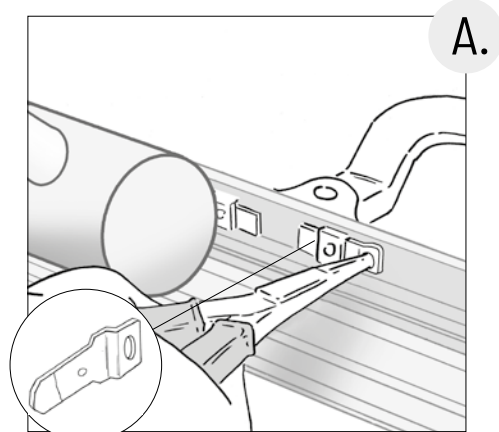

Detach the espagnolette handle from the glazing bead by knocking all the wedges out.

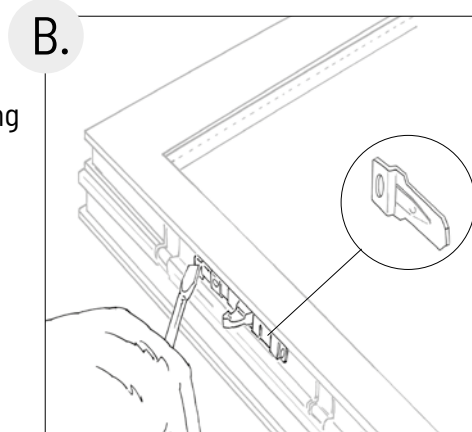

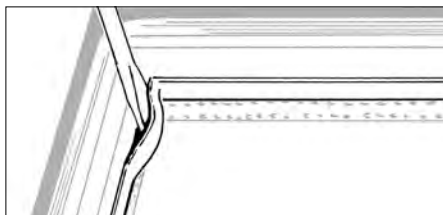
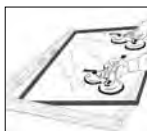

Remove the internal glazing gasket by sliding a flat bladed tool between the bead and underside of the gasket and gently lever upwards.

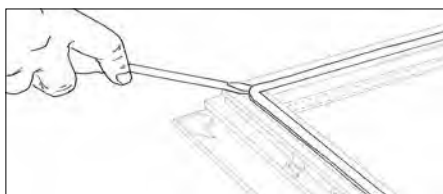
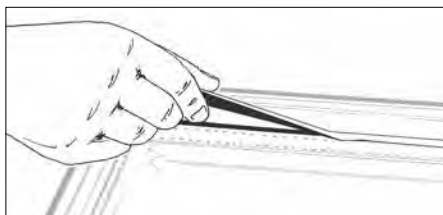

Starting at the bottom and working up either sided remove the primary seal gasket by sliding a flat bladed tool between the inner edge of the sash and the underside of the gasket and gently lever upwards.

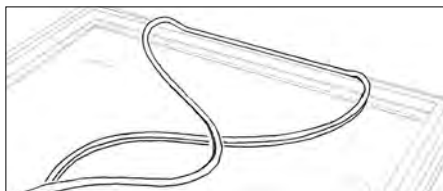
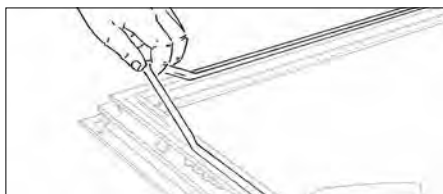

The gasket at the top is bonded and should remain in place.

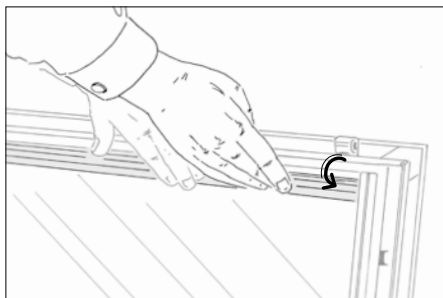
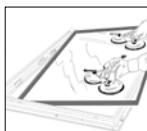

On both sides tip the glazing beads inwards and remove followed by the top and bottom. Ensure bonding agent has been detached.

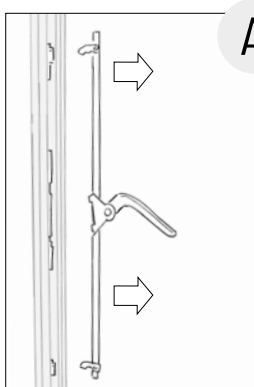

A.

A. VELFAC 200 ENERGY (TGU) or VELFAC 200i (DGU) with thermally broken sash profile:

Once the glazing bead behind the espagnolette handle has been removed, place the handle in the 'open' position.

Tilt the cremone rod out by releasing the bolts (2-3 places) and tilt the handle and cremone rod out of the sash.



[See video 1:03](#)

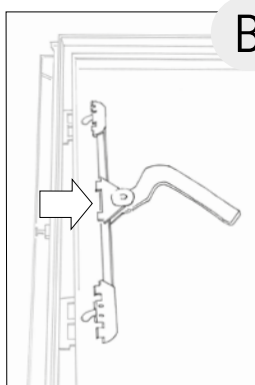

B.

B. VELFAC 200 (DGU) with unbroken aluminium sash profile:

Place the handle in the 'open' position, remove the glazing bead and take out the handle and the espagnolette system.

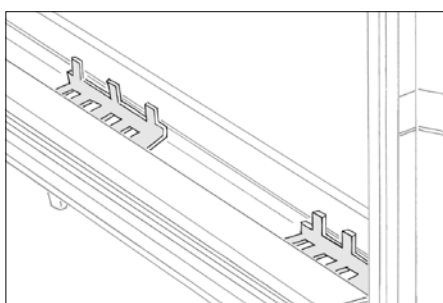

Notice the location of the glazing packers, as these must be re-installed in the exact same position during re-glazing.

Any loose glazing packers must be tilted up.

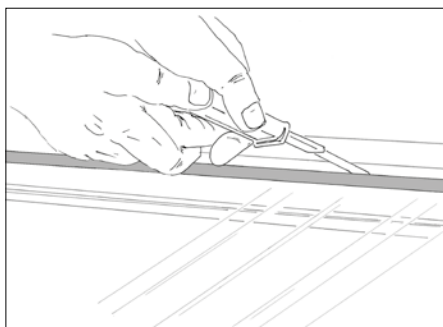

At point of manufacture a bonding agent may have been applied at intermittent locations between the sash profile and glazing rebate. To remove the glass the contact bond will need breaking and the remaining glazing packers tilted up.

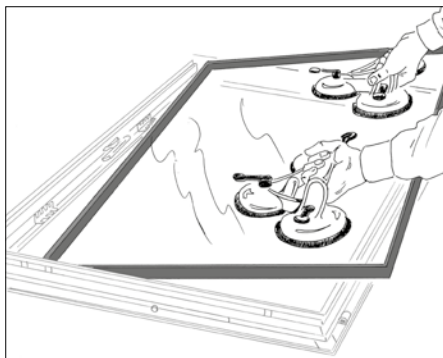
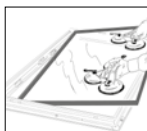

Once free of the bonding agent the glass unit can be lifted from the sash using the appropriate equipment.

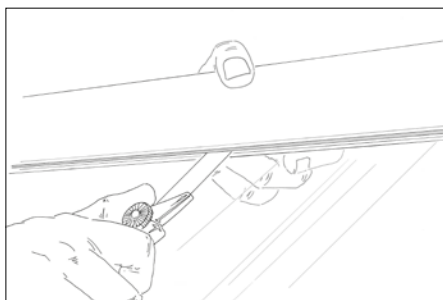

If the glazed unit remains bonded carefully stand the sash vertical on one edge to allow access to the outer face. Soften the external glazing gaskets with a solution of mild detergent and water, and at the points where a bond remains in place, slide a flat blade tool between the external glazing gasket and glass and cut the remaining seal.



[See video 1:52](#)

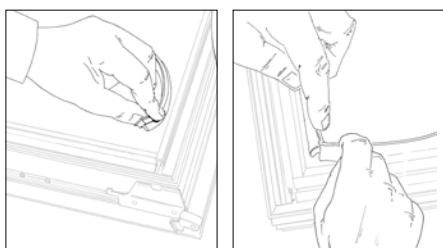

The external glazing gasket must be replaced if damaged: Start and end at the top.

The gasket must be compressed during installation and cut off with an excess of 1 cm. Finish by cutting the corners slightly.



[See video 2:14](#)

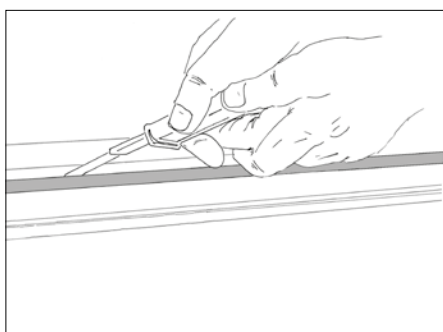
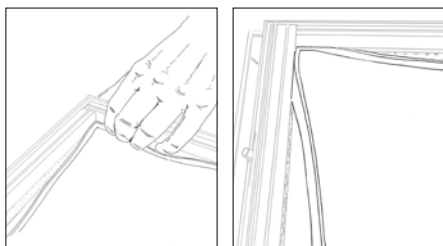

**Before installing a new pane:**

- Clean any glue residues that may be present on the new pane.
- Clean any glue residues behind the espagnolette handle.



[See video 2:57](#)

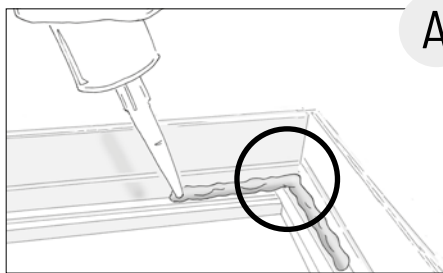
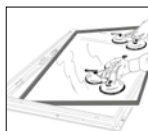

A.

- Gun in a sealing joint at the bottom of the sash and behind the cremone handle.
- Ensure that sealing behind the sash corners is intact.
- The new pane must be sealed with a bonding agent in the same places as before, use MS Polymer or equivalent, e.g. Illbruck SP 350.



[See video 3:15](#)

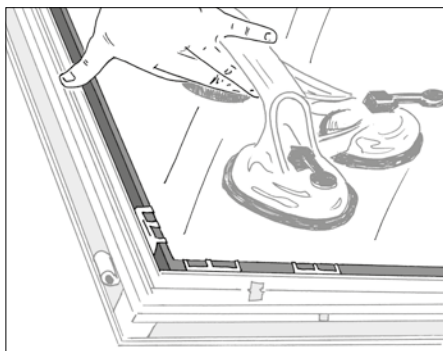

**Re-glazing:**

- Place the pane down in the middle of the sash so that the free space on all sides is equal.
- Refit the glazing packers as before, and re-seal the unit. Check the diagonal dimensions and adjust glazing packers if necessary.

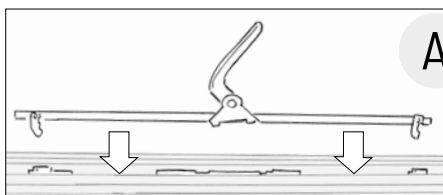
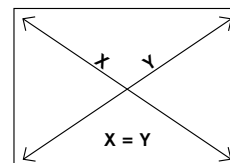

A.

**A. Refit the handle and espagnolette mechanism:**

- Slide one bolt into position (8) and click into sash.
- Fit the handle beneath the retaining bracket, one side at a time (9).
- Click the remaining bolts in place in the sash in the same way (8).
- Check that the handle functions properly.
- Ensure all moving parts are lubricated.



[See video 4:19](#)

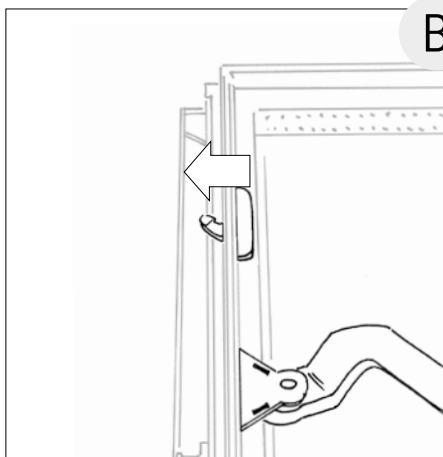
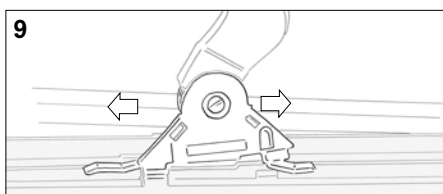

B.

**B. Refit the handle and espagnolette mechanism:**

- The handle is re-installed by clicking the bolts in place in the sash.
- Check that the handle functions properly.



[See video 4:50](#)



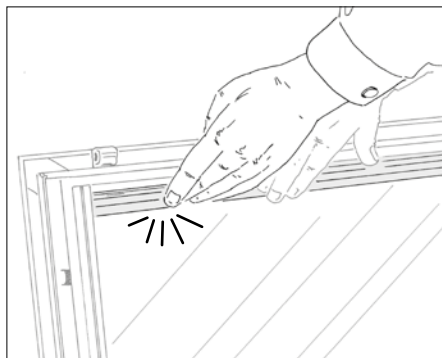
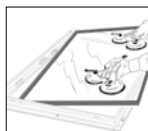

Click the glazing beads into position – start at the top and bottom.



[See video 4:41](#)

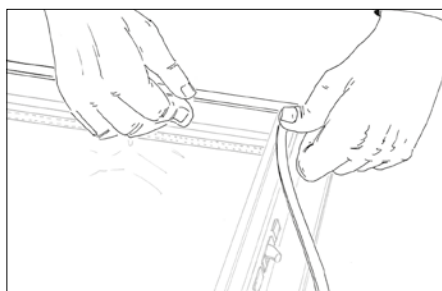

Attach the weather strip, starting at the top, then proceed to the corners and sides.

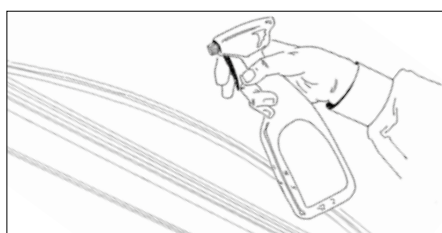

**Tip:** Soften the gaskets and weather strips with soapy water.

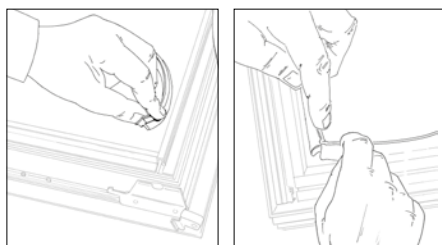

Press the glass gaskets into position. Start at the bottom and end at the top of the sash. Press the glass gasket in at all corners and then proceed to the sides. Be careful not to twist the gasket.

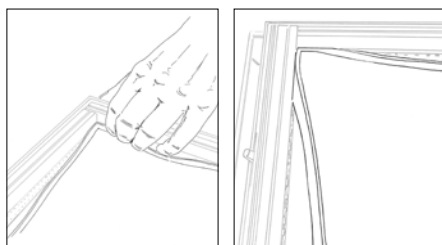

**Tip:** When replacing the gasket: An excess of 1 cm must be cut off from each side of the gasket. Cut off a slight amount from the corners and compress the gasket during installation.



[See video 5:22](#)

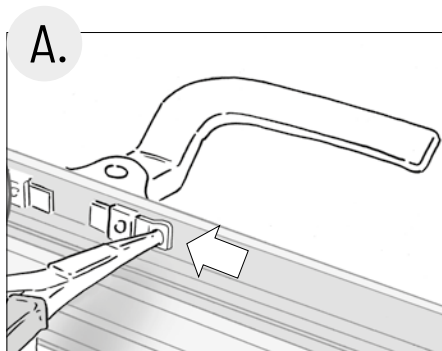

**A.**

**A.+B. The espagnolette mechanism and handle are secured by re-installing the wedges.**

Control the handle for smooth operation.

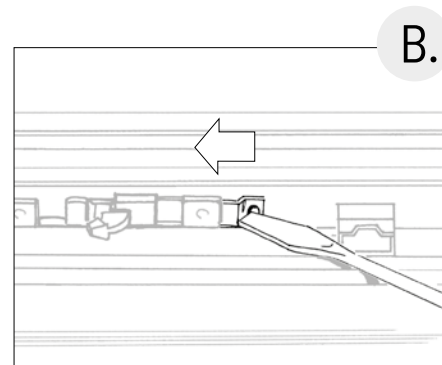

**B.**

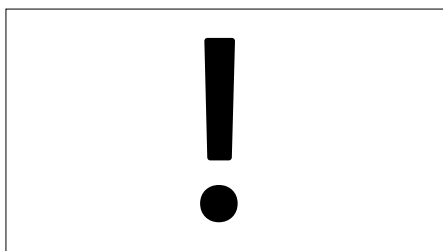
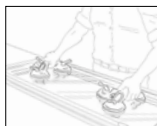

Due to the amount of work and the health and safety, we strongly recommend a sash and glass replacement. For fixed glazing please follow the below guide.

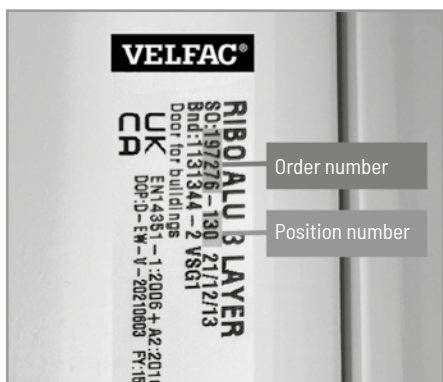

**Glass breakage:** To order replacement glass units you will need the Order Number and the Position Number. These are shown on the unique ID tag allocated to each window, generally located in the bottom left rebate of any opening unit. For fixed units the ID Tag is located in either the right or left hand upper corner of the timber mainframe.

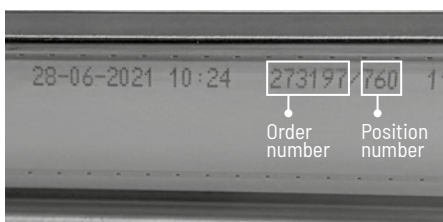

If no ID tags are visible, the required information is available on the glass spacer bar. This information is critical to ensure the correct specification of glass is re-supplied by the Aftersales Department.



[See the video](#)

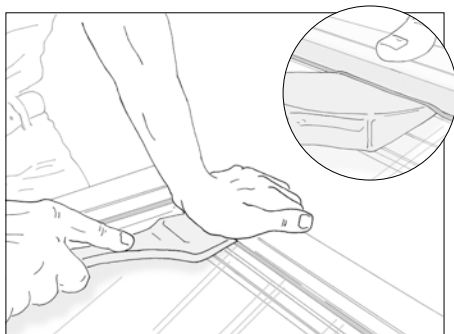

The aluminium cladding is mounted on retaining clips that sit underneath. To dismantle use a plastic glazing paddle. Starting in the middle gently position the glazing paddle between the edge of the aluminium cladding and outer face of the glazing, then lever upwards. All clips must be disengaged. The clips are placed 120mm from each corner and with a max. distance of 350mm around the entire sash.

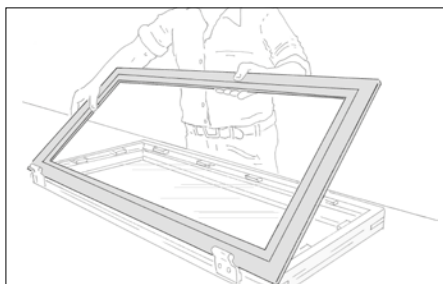

The aluminium cap / glazing bead is then tipped off. For sidehung variants the aluminium cladding is then lifted from the closing side first then gently removed from under hinges.

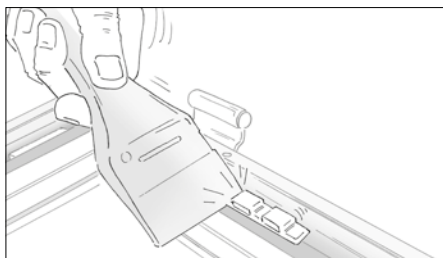

The glazing clips that sit around the perimeter of the glazed unit are removed by pushing them upwards using a plastic glazing paddle, all clips should be removed. Top, bottom and around the corners, they must be pushed away from the corners. Remaining glazing clips in the sides of the sash must be pushed upwards.

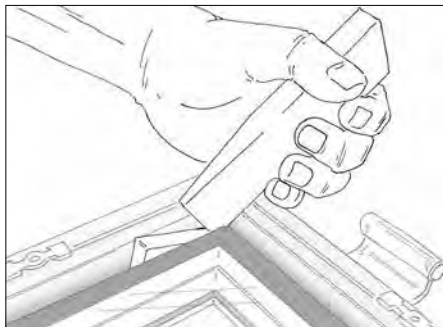

Glazing packers that have been placed to stabilise the unit within the frame also need removing.

Cut the glazing free of the safety sealant with a Stanley knife or fine cutter – make sure that the sealant is cut through.

In newer windows glue packers have been used. These are filled with bonding agent and must be split in halves with a fine cutter.

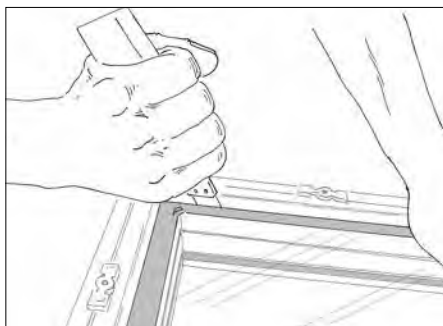

In all 4 corners, the pane is inserted with a bonding agent. This must be cut with a Stanley knife.

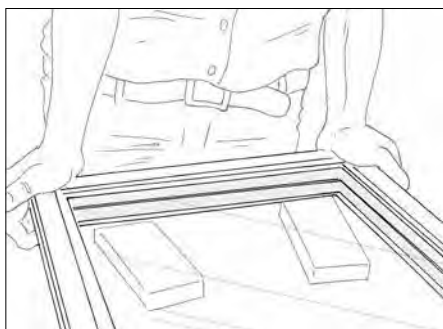

Support the glazing with a couple of blocks to make the sash free of the table. Now press the sash downwards on all sides to release the glazing.

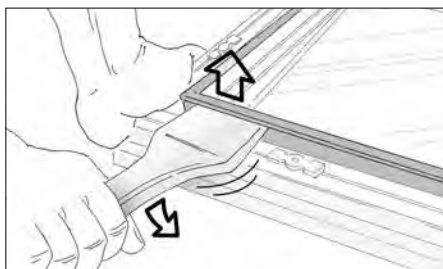

At the same time, lift up the glazing with a glazing paddle by lifting the upper pane.

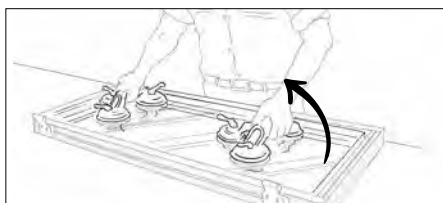

When the glazing is free, tip or lift it out.

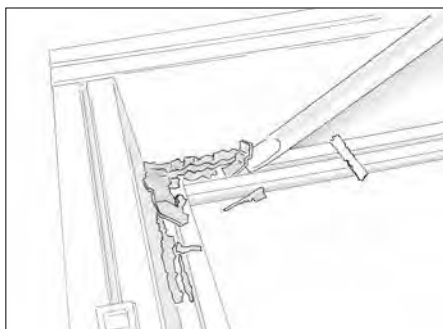

The remaining safety sealant must be removed e.g. with a trimming knife or a wood chisel.

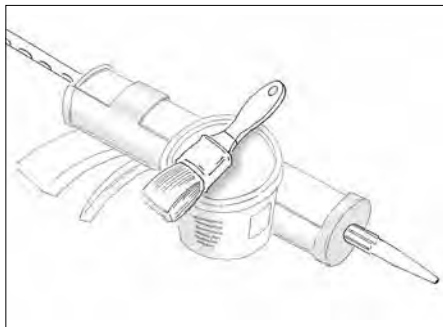

**Installation of the new glazing.** The new glazing is safety glued as before with Illbruck SP 350. Exposed wood, which will not be covered by the safety sealant, must first be surface treated with paint containing fungicides.

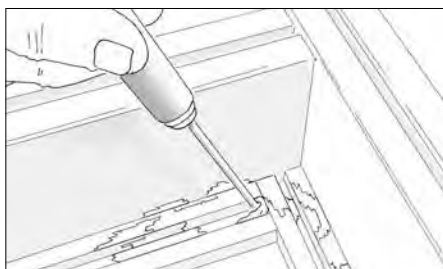

Clean the grooves for the gaskets in all corners for joint sealant, e.g. with a screwdriver. A new gasket is installed. It is first installed in the sides with through grooves. Make sure that the gaskets are sufficiently assembled in the corners (1-2mm overlength).

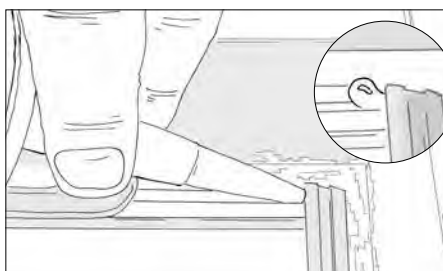

At gasket junctions apply Illbruck SP 350 at both ends and squeeze tightly to ensure a bond is gained.

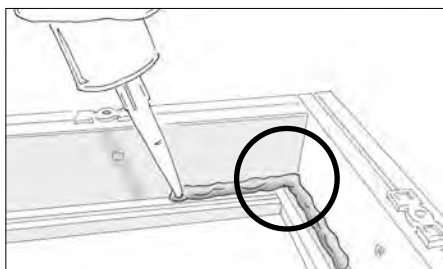

Reinstate the security sealant as before using Illbruck SP 350. Make sure the sealing of the sash corners is intact.



Place the pane central in the sash and reinstate the glazing packers as before.

We recommend using VELFAC glue packers (can be bought at the VELFAC Service Department) and fill them with Illbruck SP 350.

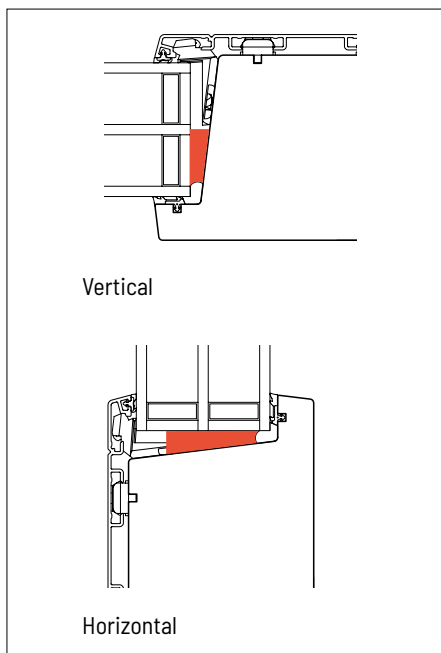
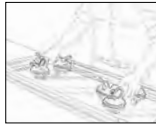

If you do not use VELFAC glue packers, then safety-glyce the corners (+ in the middle for sashes >1200mm):

- On the vertical seal junctions the sealant must be applied to a depth of 50% of the glazed unit.
- At the horizontal location this can be increased up to a maximum depth of 75% of the glazed unit.

The exception to the above is each bottom corner of newly installed glazed panel, the sealant positioned on the vertical plane must be tooled back to give an approximate angle of 35-45degrees, this then allows water to be channelled forward towards the system drainage path.

If this detailing is not applied water may become trapped in the system which could lead to rotting of timber profiles or water ingress manifesting along the internal cill line.

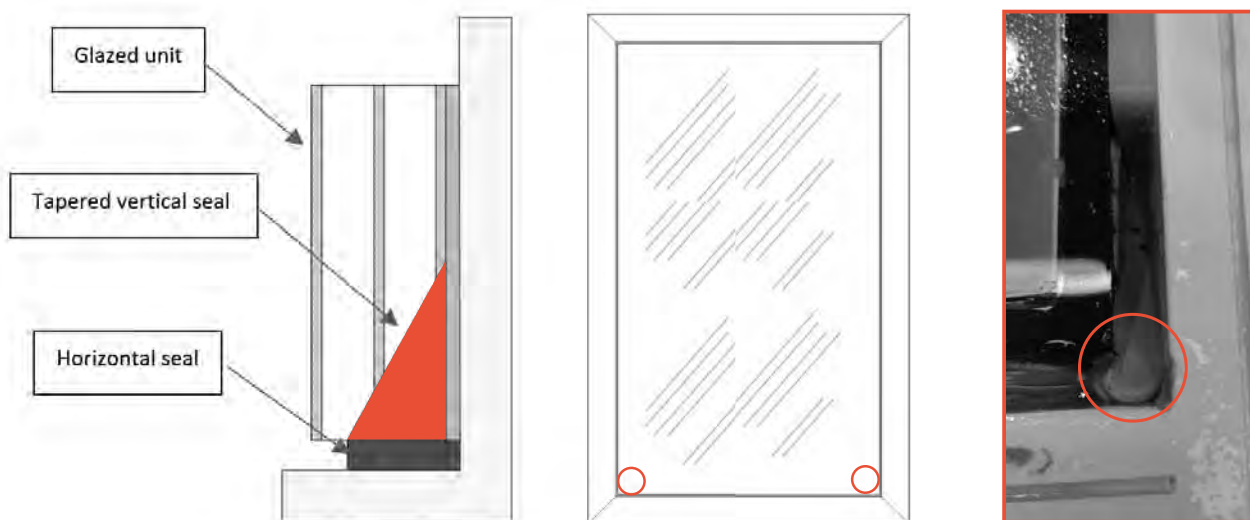

Reinstate the glazing clips as before (120mm from each corner and with max. centres of 350mm). Start mid-sash. In the top and bottom and around the corners, push them towards the corners. Remaining glazing clips in the sides of the sash must be installed from the top and downwards. Using a rubber mallet the aluminium cladding is snapped back onto the retaining clips.

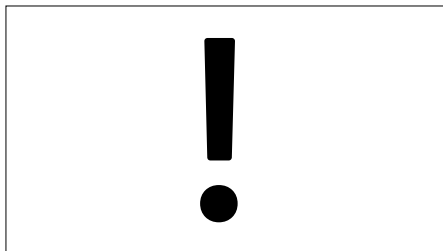

Due to the amount of work and the health and safety, we strongly recommend a sash and glass replacement. For fixed glazing please follow the below guide.

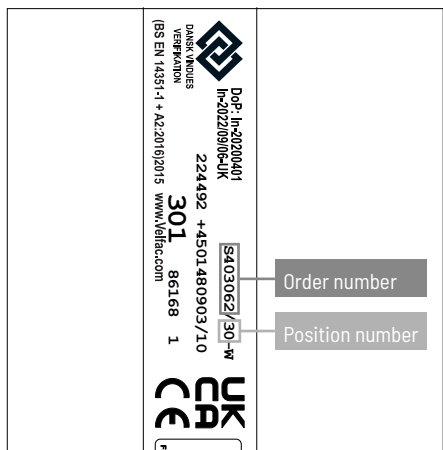

**Glass breakage:** To order replacement glass units you will need the Order Number and the Position Number. These are shown on the unique ID tag allocated to each window, generally located in the bottom left rebate of any opening unit. For fixed units the ID Tag is located in either the right or left hand upper corner of the timber mainframe. If no ID tags are visible, the required information is available on the glass spacer bar. This information is critical to ensure the correct specification of glass is re-supplied by the Aftersales Department.

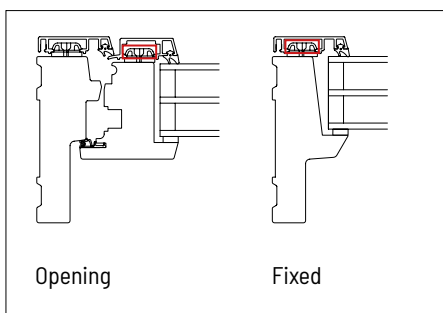

The external aluminium cladding must be removed prior to replace the glazing. The cladding is mounted on retaining clips, here marked with red.

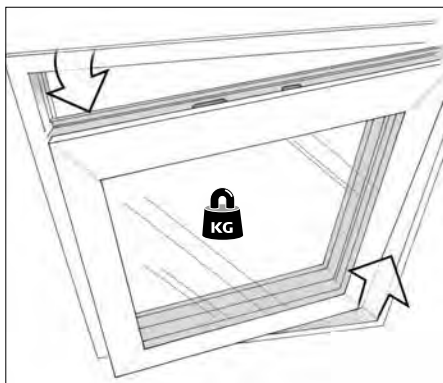

Desash the window/casement door (please see page 122). For fixed glazing just follow the below steps.



The aluminium cladding is mounted on retaining clips that sit underneath the cladding. To dismount use a cladding clip tool (item no. IO\_P511):

- Insert the clip tool between cladding and wood frame.
- Catch the first retaining clip...

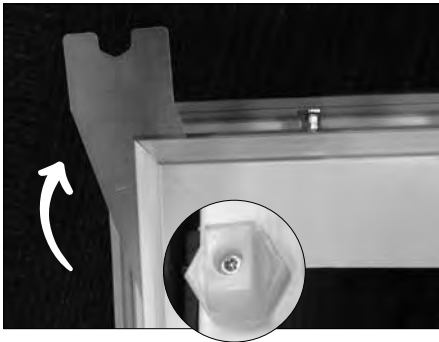
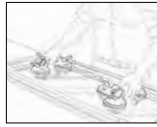

... and turn it 90°.

All retaining clips must be disengaged to free the aluminium cladding. The clips are placed 120mm from each corner and with a max. distance of 350mm around the entire sash. Should a clip brake during the process it must be replaced (item no. IO\_P510).

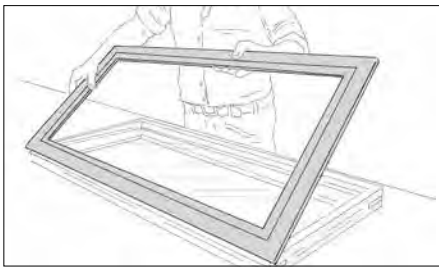

The aluminium cladding / glazing bead is then tipped off.

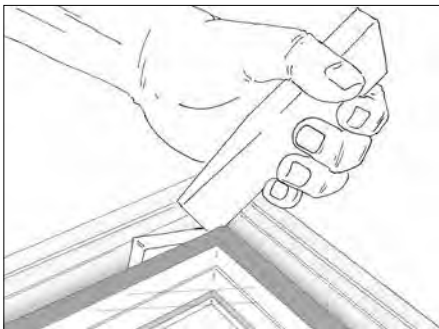

Glazing packers that have been placed to stabilise the unit within the frame also need removing.

Cut the glazing free of the safety sealant with a Stanley knife or fine cutter - make sure that the sealant is cut through.

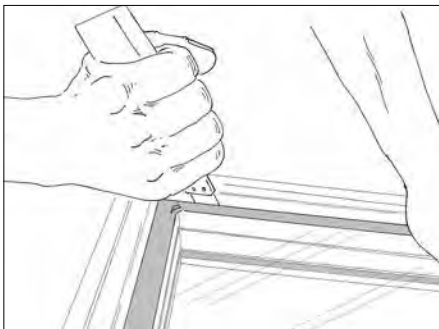

In all 4 corners, the pane is inserted with a bonding agent. This must be cut with a Stanley knife or fine cutter.

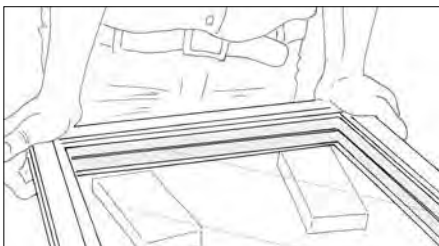

Support the glazing with a couple of blocks to make the sash free of the table. Now press the sash downwards on all sides to release the glazing.

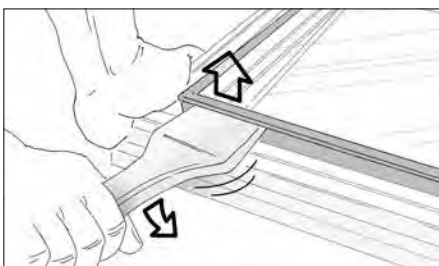

At the same time, lift up the glazing with a glazing paddle by lifting the upper pane.

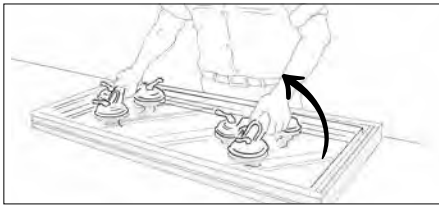
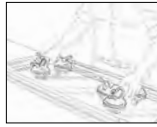

When the glazing is free, tip or lift it out.

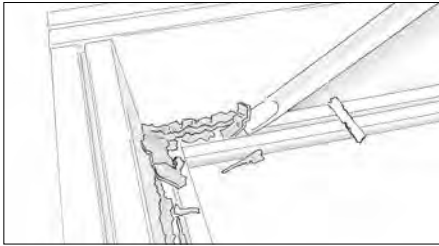

The remaining safety sealant must be removed e.g. with a trimming knife or a wood chisel.

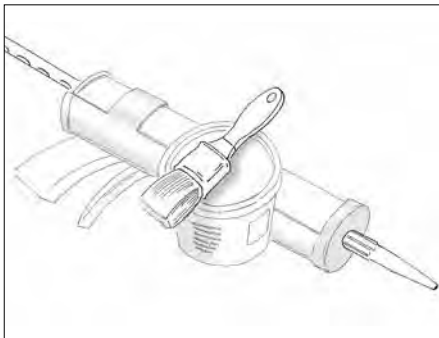

**Installation of the new glazing.** The new glazing is safety glued as before with Illbruck SP 350. Exposed wood, which will not be covered by the safety sealant, must first be surface treated with paint containing fungicides.

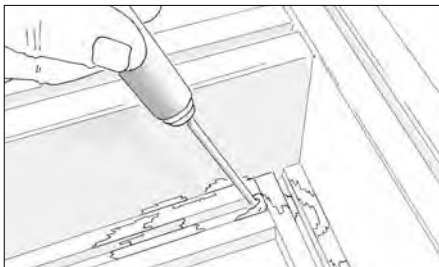

Clean the grooves for the gaskets in all corners for joint sealant, e.g. with a screwdriver. A new gasket is installed. It is first installed in the sides with through grooves. Make sure that the gaskets are sufficiently assembled in the corners (1-2mm overlength).

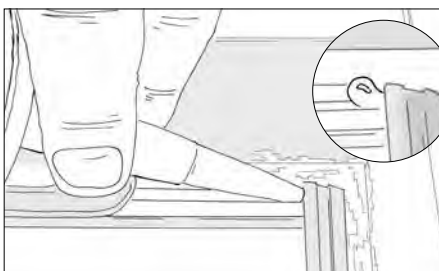

At gasket junctions apply Illbruck SP 350 at both ends and squeeze tightly to ensure a bond is gained.

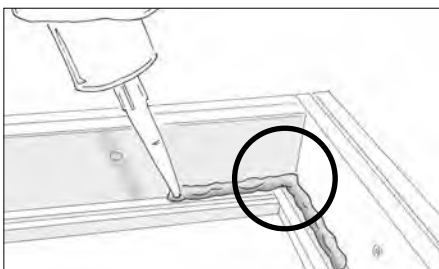

Reinstate the security sealant as before using Illbruck SP 350. Make sure the sealing of the sash corners is intact.



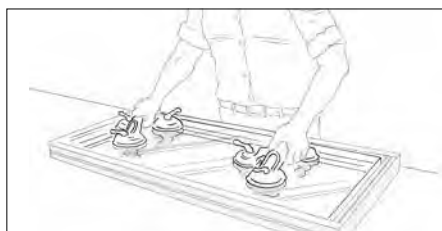
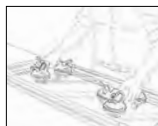

Place the pane central in the sash and reinstate the glazing packers as before.

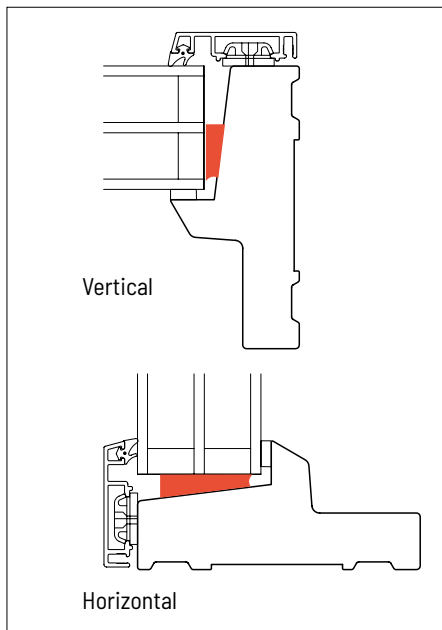

Now safety-glove the corners (and in the middle of sashes >1200mm):

- On the vertical seal junctions the sealant must be applied to a depth of 50% of the glazed unit.
- At the horizontal location this can be increased up to a maximum depth of 75% of the glazed unit.

The exception to the above is each bottom corner of newly installed glazed panel, the sealant positioned on the vertical plane must be tooled back to give an approximate angle of 35-45degrees, this then allows water to be channelled forward towards the system drainage path.

If this detailing is not applied water may become trapped in the system which could lead to rotting of timber profiles or water ingress manifesting along the internal cill line.

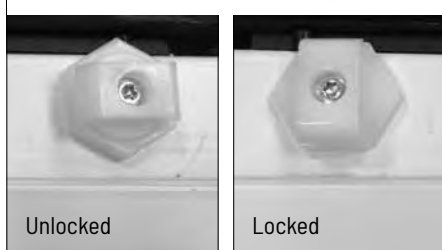
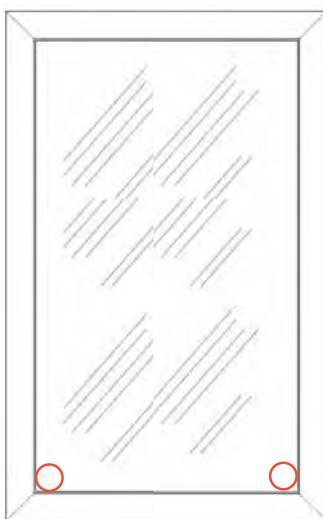
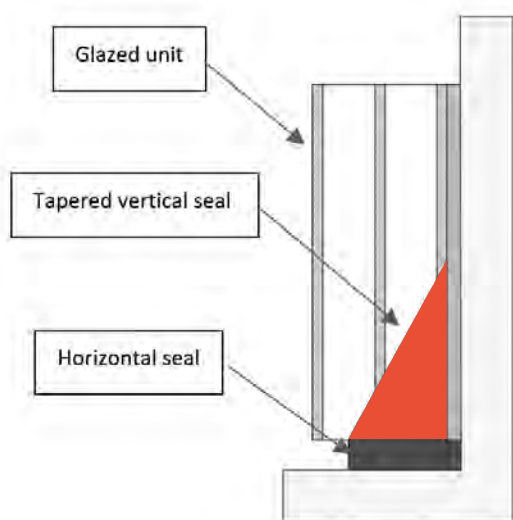

Turn all the retaining clips 90° into the locked position and click the aluminium cladding in place on the retaining clips.

Should a clip brake during the process it must be replaced (item no. IO\_P510).

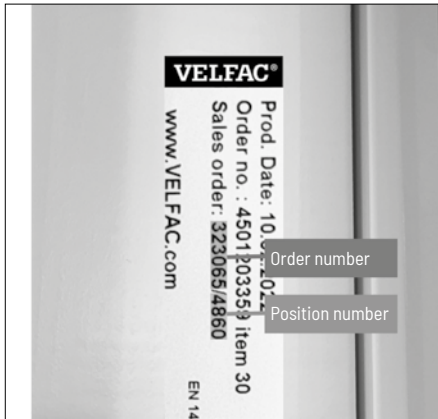

**Glass breakage:** To order replacement glass units you will need the Order Number and the Position Number. These are shown on the unique ID tag allocated to each window, generally located in the bottom left rebate of any opening unit. For fixed units the ID Tag is located in either the right or left hand upper corner of the timber mainframe. If no ID tags are visible, the required information is available on the glass spacer bar. This information is critical to ensure the correct specification of glass is re-supplied by the Aftersales Department.

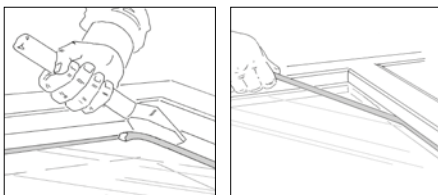

Remove the door from its outer casing and place onto trestles or similar. Using a pallet knife gently remove the internal gaskets.

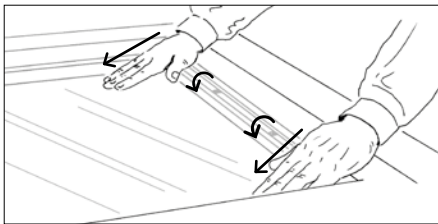

Tip the glazing beads towards the face of the glazed unit and then remove - side glazing beads first.

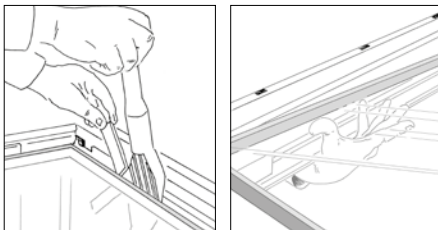

Remove any factory applied packing / sealant from the perimeters of the glazed unit and lift out.

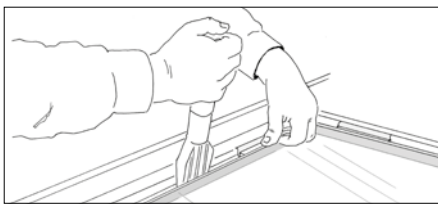

Clean down any sealant residue from the door rebate. Lift and place into the door the replacement unit and perimeter pack and seal as before. Check the diagonal dimensions.

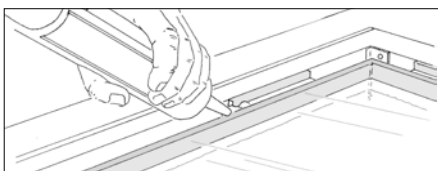

When packing along the bottom edge of the unit these glazing packers should be bonded in place.

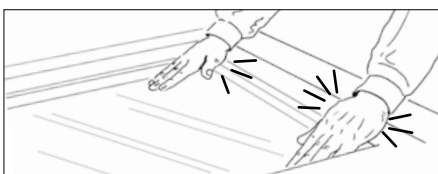

Reinstate the glazing beads - top and bottom first.



Reinstate the glazing gaskets - top and bottom first. Make sure the top and bottom gaskets are pushed in completely.



DANISH WINDOW VERIFICATION



Ask for our FSC<sup>®</sup>-certified products.

The mark of responsible forestry

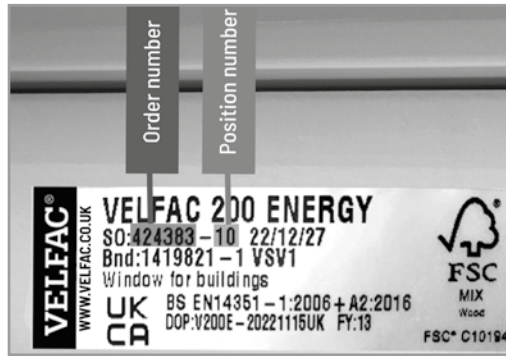

Before contacting VELFAC:  
Please find the id. tag usually located in the rebate.

## VELFAC

at DOVISTA UK Limited  
The Forum, Ground Floor  
Lancaster Way  
Ermine Business Park  
Huntingdon, Cambridgeshire  
PE29 6XU

[www.VELFAC.co.uk](http://www.VELFAC.co.uk)

VELFAC After sales service:  
Tel. 01480 759 510  
[service@VELFAC.co.uk](mailto:service@VELFAC.co.uk)

