

Fitting of the standard restrictor

(VELFAC 200 alu / VELFAC 200i / VELFAC 200 ENERGY / VELFAC Edge)

N.B: The restrictor may be positioned in the closing side of the jamb or in the cill.
N.B. There are 3 types of standard restrictors, however with same installation method.

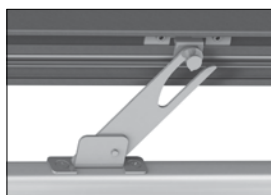

VELFAC 200 DGU
(seen from outside)



VELFAC 200 ENERGY
+ VELFAC Edge



VELFAC 200 ENERGY
+ VELFAC Edge

Tip: Cut the template out and place it on the frame. Then you will know exactly where to drill.

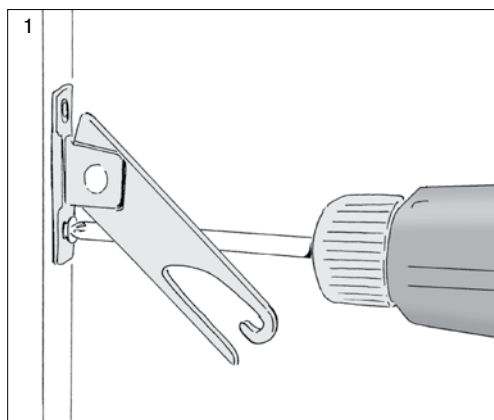
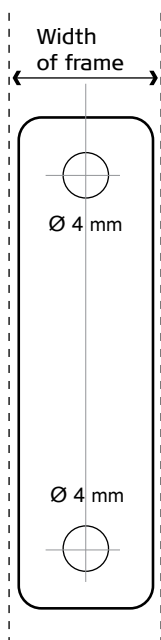

Place the frame part of the restrictor at the required height with the hook turning downwards.

Mark out the drilling holes in the middle of the front edge of the frame using the template on this page. Pre-drill holes (Ø4mm) and fasten the frame part with five 40mm screws.

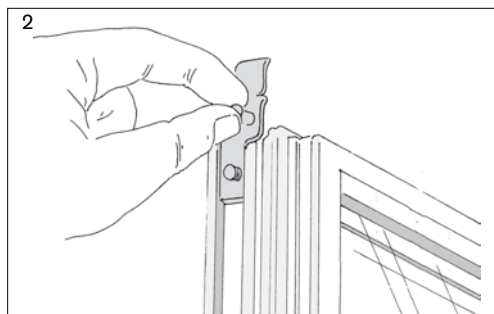

Let the frame part (with pin) slip into the sash groove.

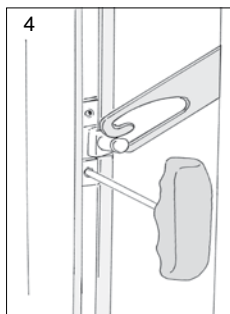
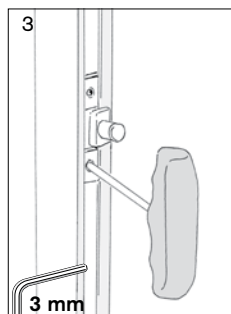

Place the frame part in a fully open position - like (1) or the pictures to the left. Fasten the sash part (3) and make sure that it is positioned exactly as illustrated (4).

Pull the sash back and check that the restrictor engages properly. If necessary, loosen the frame part and move it slightly.

N.B. Required window size:

Installation at the cill requires a window wider than 500mm.

Installation at the jamb requires a window higher than 500mm.

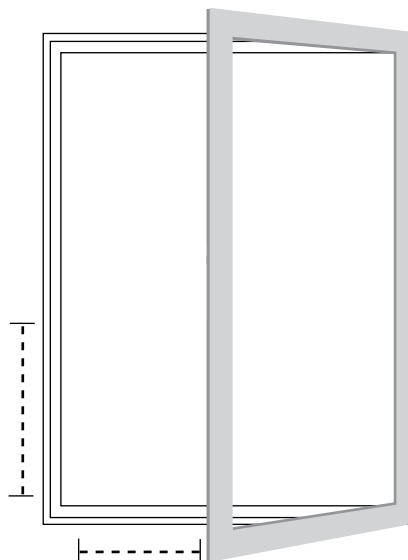

PLACEMENT:

Sidehung windows: the restrictor may be fitted within the area shown on the drawing.

Side-guided windows: the restrictor may only be fitted on the jamb.

Top-guided windows: the restrictor may only be fitted on the cill.

NB: Please make sure the restrictor does not conflict with the espagnolette handle, vents etc. Please keep a minimum distance of 5-6mm to the striking plate.